

# KOE

---

## JDI Group

Kaohsiung Opto-Electronics Inc.

FOR MESSRS : \_\_\_\_\_

DATE : Dec. 18<sup>th</sup>, 2017

### CUSTOMER'S ACCEPTANCE SPECIFICATIONS

### TX09D200VM0BPA

#### Contents

No.	ITEM	SHEET No.	PAGE
1	COVER	7B64PS 2701-TX09D200VM0BPA-4	1-1/1
2	RECORD OF REVISION	7B64PS 2702-TX09D200VM0BPA-4	2-1/1
3	GENERAL DATA	7B64PS 2703-TX09D200VM0BPA-4	3-1/1
4	ABSOLUTE MAXIMUM RATINGS	7B64PS 2704-TX09D200VM0BPA-4	4-1/1
5	ELECTRICAL CHARACTERISTICS	7B64PS 2705-TX09D200VM0BPA-4	5-1/1
6	OPTICAL CHARACTERISTICS	7B64PS 2706-TX09D200VM0BPA-4	6-1/2~2/2
7	BLOCK DIAGRAM	7B64PS 2707-TX09D200VM0BPA-4	7-1/1
8	RELIABILITY TESTS	7B64PS 2708-TX09D200VM0BPA-4	8-1/1
9	LCD INTERFACE	7B64PS 2709-TX09D200VM0BPA-4	9-1/11~11/11
10	OUTLINE DIMENSIONS	7B64PS 2710-TX09D200VM0BPA-4	10-1/1
11	TOUCH PANEL	7B64PS 2711-TX09D200VM0BPA-4	11-1/2~2/2
12	APPEARANCE STANDARD	7B64PS 2712-TX09D200VM0BPA-4	12-1/4~4/4
13	PRECAUTIONS	7B64PS 2713-TX09D200VM0BPA-4	13-1/2~2/2
14	DESIGNATION OF LOT MARK	7B64PS 2714-TX09D200VM0BPA-4	14-1/1

ACCEPTED BY : \_\_\_\_\_

PROPOSED BY : *Oblack Tsai*

## 2. RECORD OF REVISION

DATE	SHEET No.	SUMMARY																																																					
Mar.31,'16	7B64PS 2712- TX09D200VM0BPA-2 Page 12-3/4	Revised : 12.3 TOUCH PANEL APPEARANCE SPECIFICATION																																																					
Feb.1,'17	7B64PS 2712- TX09D200VM0BPA-3 Page 12-2/4 、 4/4	12.2 LCD APPEARANCE SPECIFICATION Revised : <table border="1" style="margin-left: 20px;"> <thead> <tr> <th rowspan="2">Dot-Defect (Note 1)</th> <th colspan="2">Type</th> <th>Maximum number acceptable</th> <th rowspan="2">A,B</th> </tr> </thead> <tbody> <tr> <td rowspan="3">Sparkle mode</td> <td>1 dot</td> <td>4</td> <td rowspan="3">A,B</td> </tr> <tr> <td>2 dots</td> <td>2(sets)</td> </tr> <tr> <td>In total</td> <td>4</td> </tr> <tr> <td rowspan="3">Black mode</td> <td>1 dot</td> <td>4</td> <td rowspan="3">A,B</td> </tr> <tr> <td>2 dots</td> <td>2(sets)</td> </tr> <tr> <td>In total</td> <td>4</td> </tr> <tr> <td>Sparkle mode &amp; Black mode</td> <td>2 dots</td> <td>2(sets)</td> <td></td> </tr> <tr> <td colspan="2">In total</td> <td>6</td> <td></td> </tr> </tbody> </table> <p style="text-align: center;">↓</p> <table border="1" style="margin-left: 20px;"> <thead> <tr> <th rowspan="2">Dot-Defect (Note 1)</th> <th colspan="2">Type</th> <th>Maximum number acceptable</th> <th rowspan="2">A,B</th> </tr> </thead> <tbody> <tr> <td rowspan="2">Bright dot-defect</td> <td>1 dot</td> <td>0</td> <td rowspan="2">A,B</td> </tr> <tr> <td>Dark dot-defect</td> <td>1 dot</td> <td>4</td> </tr> <tr> <td></td> <td>2 dots</td> <td>1(sets)</td> <td></td> </tr> <tr> <td></td> <td>In total</td> <td>4</td> <td></td> </tr> <tr> <td colspan="2">In total</td> <td>4</td> <td></td> </tr> </tbody> </table> <p>Note 1 : Revise The definitions of dot defect</p>	Dot-Defect (Note 1)	Type		Maximum number acceptable	A,B	Sparkle mode	1 dot	4	A,B	2 dots	2(sets)	In total	4	Black mode	1 dot	4	A,B	2 dots	2(sets)	In total	4	Sparkle mode & Black mode	2 dots	2(sets)		In total		6		Dot-Defect (Note 1)	Type		Maximum number acceptable	A,B	Bright dot-defect	1 dot	0	A,B	Dark dot-defect	1 dot	4		2 dots	1(sets)			In total	4		In total		4	
Dot-Defect (Note 1)	Type			Maximum number acceptable	A,B																																																		
	Sparkle mode	1 dot	4	A,B																																																			
2 dots		2(sets)																																																					
In total		4																																																					
Black mode	1 dot	4	A,B																																																				
	2 dots	2(sets)																																																					
	In total	4																																																					
Sparkle mode & Black mode	2 dots	2(sets)																																																					
In total		6																																																					
Dot-Defect (Note 1)	Type		Maximum number acceptable	A,B																																																			
	Bright dot-defect	1 dot	0		A,B																																																		
Dark dot-defect		1 dot	4																																																				
	2 dots	1(sets)																																																					
	In total	4																																																					
In total		4																																																					
Dec.18,'17	7B64PS 2711- TX09D200VM0BPA-4 Page 11-1/2 、 2/2	11.2 ELECTRICAL CHARACTERISTICS Revised : <table border="1" style="margin-left: 20px;"> <thead> <tr> <th colspan="2">Item</th> <th>Specification</th> <th>→</th> <th>Specification</th> </tr> </thead> <tbody> <tr> <td rowspan="2">Resistance Between Terminal</td> <td>XR-XL</td> <td>200~650Ω</td> <td></td> <td>100~750Ω</td> </tr> <tr> <td>YU-YL</td> <td>250~500Ω</td> <td></td> <td>310~950Ω</td> </tr> </tbody> </table> 11.3 MECHANICAL CHARACTERISTICS Revised : <table border="1" style="margin-left: 20px;"> <thead> <tr> <th>Item</th> <th>Specification</th> <th>Remarks</th> </tr> </thead> <tbody> <tr> <td>Surface Hardness</td> <td>3H min.</td> <td>JIS K 5400</td> </tr> </tbody> </table> <p style="text-align: center;">↓</p> <table border="1" style="margin-left: 20px;"> <thead> <tr> <th>Item</th> <th>Specification</th> <th>Remarks</th> </tr> </thead> <tbody> <tr> <td>Surface Hardness</td> <td>3H min.</td> <td>JIS K-5600-5-4</td> </tr> </tbody> </table>	Item		Specification	→	Specification	Resistance Between Terminal	XR-XL	200~650Ω		100~750Ω	YU-YL	250~500Ω		310~950Ω	Item	Specification	Remarks	Surface Hardness	3H min.	JIS K 5400	Item	Specification	Remarks	Surface Hardness	3H min.	JIS K-5600-5-4																											
Item		Specification	→	Specification																																																			
Resistance Between Terminal	XR-XL	200~650Ω		100~750Ω																																																			
	YU-YL	250~500Ω		310~950Ω																																																			
Item	Specification	Remarks																																																					
Surface Hardness	3H min.	JIS K 5400																																																					
Item	Specification	Remarks																																																					
Surface Hardness	3H min.	JIS K-5600-5-4																																																					

### 3. GENERAL DATA

#### 3.1 DISPLAY FEATURES

This module is a 3.5" QVGA of 3:4 format amorphous silicon TFT. The pixel format is vertical stripe and sub pixels are arranged as R(red), G(green), B(blue) sequentially. This display is RoHS compliant, and COG (chip on glass) technology and LED backlight are applied on this display

Part Name	TX09D200VM0BPA
Module Dimensions	65.68(W) mm x 88.8(H) mm x 10.85(D) mm
LCD Active Area	53.28(W) mm x 71.04(H) mm
Pixel Pitch	0.222(W) mm x 0.222(H) mm
Resolution	240 x 3(RGB)(W) x 320(H) dots
Color Pixel Arrangement	R, G, B Vertical stripe
LCD Type	Transmissive Color TFT; Normally Black
Display Type	Active Matrix
Number of Colors	16.7M Colors (8-bit RGB)
Backlight	Light Emitting Diode (LED)
Weight	82g
Interface	CMOS; 50 pins
Power Supply Voltage	3.3V for LCD ; 12V for Backlight
Power Consumption	82.5mW for LCD; 1020mW for B/L
Viewing Direction	Super Wide Version (In Plane Switching)
Touch Panel	Resistance type; 4-wire type; Anti-glare Surface

## 4. ABSOLUTE MAXIMUM RATINGS

Item	Symbol	Min.	Max.	Unit	Remarks
Supply Voltage	$V_{DD}$	-0.3	4.0	V	-
Input Voltage of Logic	$V_I$	-0.3	$V_{DD} + 0.3$	V	Note 1
Operating Temperature	Top	-20	70	°C	Note 2
Storage Temperature	Tst	-30	80	°C	Note 2

Note 1: The rating is defined for the signal voltages of the interface such as Hsync, Vsync, DE, DCLK and RGB data bus.

Note 2: The maximum rating is defined as above based on the chamber temperature, which might be different from ambient temperature after assembling the panel into the application. Moreover, some temperature-related phenomenon as below needed to be noticed:

- Background color, contrast and response time would be different in temperatures other than 25°C.
- Operating under high temperature will shorten LED lifetime.

## 5. ELECTRICAL CHARACTERISTICS

### 5.1 LCD CHARACTERISTICS

$T_a = 25\text{ }^\circ\text{C}$ ,  $V_{SS} = 0\text{V}$

Item	Symbol	Condition	Min.	Typ.	Max.	Unit	Remarks
Power Supply Voltage	$V_{DD}$	-	3.0	3.3	3.6	V	-
Input Voltage of Logic	$V_I$	"H" level	$0.7V_{DD}$	-	$V_{DD}$	V	Note 1
		"L" level	$V_{SS}$	-	$0.3V_{DD}$		
Power Supply Current	$I_{DD}$	$V_{DD}-V_{SS}=3.3\text{V}$	-	25	40	mA	Note 2,3
Frame Frequency	$f_{Frame}$	-	-	60	66	Hz	-
CLK Frequency	$f_{CLK}$	-	6.0	6.5	7.0	MHz	

Note 1: The rating is defined for the signal voltages of the interface such as Hsync, Vsync, DE, DCLK and RGB data bus.

Note 2: An all white check pattern is used when measuring  $I_{DD}$ ,  $f_{Frame}$  is set to 60 Hz.

Note 3: 0.32A fuse is applied in the module for  $I_{DD}$ . For display activation and protection purpose, power supply is recommended larger than 0.8A to start the display and break fuse once any short circuit occurred.

### 5.2 BACKLIGHT CHARACTERISTICS

$T_a = 25\text{ }^\circ\text{C}$

Item	Symbol	Condition	Min.	Typ.	Max.	Unit	Remarks
LED Input Voltage	$V_{LED}$	-	11.5	12.0	12.5	V	Note1
LED Forward Current	$I_{LED}$	0V; 0% duty	65	85	100	mA	Note 2
		3.3VDC; 100% duty	10	18	25		
LED lifetime	-	$I_{LED}=85\text{ mA}$	-	70K	-	hrs	Note 3

Note 1: As Fig. 5.1 shown, LED current is constant, 85 mA, controlled by the LED driver when applying 12V  $V_{LED}$ .

Note 2: Dimming function can be obtained by applying DC voltage or PWM signal from the display interface CN1. The recommended PWM signal is 1K ~ 10K Hz with 3.3V amplitude.

Note 3: The estimated lifetime is specified as the time to reduce 50% brightness by applying 85 mA at  $25\text{ }^\circ\text{C}$ .

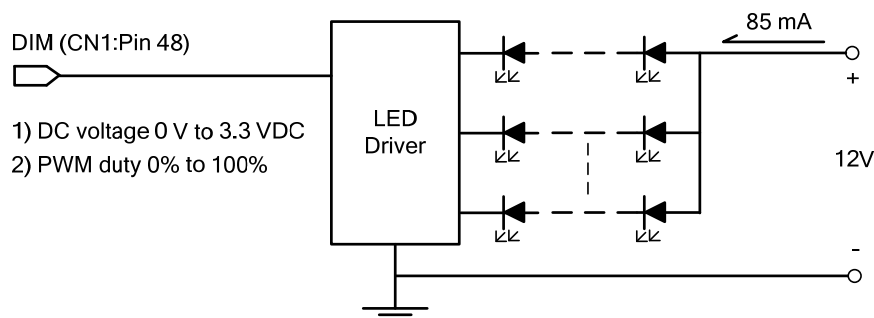

Fig 5.1

## 6. OPTICAL CHARACTERISTICS

The optical characteristics are measured based on the conditions as below:

- Supplying the signals and voltages defined in the section of electrical characteristics.
- The backlight unit needs to be turned on for 30 minutes.
- The ambient temperature is 25 °C.
- In the dark room less than 100 lx, the equipment has been set for the measurements as shown in Fig 6.1.

$$T_a = 25 \text{ }^\circ\text{C}, f_{\text{Frame}} = 60 \text{ Hz}, V_{\text{DD}} = 3.3\text{V}$$

Item	Symbol	Condition	Min.	Typ.	Max.	Unit	Remarks
Brightness of White	-	$\phi = 0^\circ, \theta = 0^\circ,$ $I_{\text{LED}} = 85\text{mA}$	384	480	-	cd/m <sup>2</sup>	Note 1
Brightness Uniformity	-		75	-	-	%	Note 2
Contrast Ratio	CR		720	900	-	-	Note 3
Response Time		$\phi = 0^\circ, \theta = 0^\circ$	-	-	53	ms	-
NTSC Ratio	-	$\phi = 0^\circ, \theta = 0^\circ$	-	65	-	%	-
Viewing Angle	$\theta_x$	$\phi = 0^\circ, \text{CR} \geq 10$	-	85	-	Degree	Note 5
	$\theta_{x'}$	$\phi = 180^\circ, \text{CR} \geq 10$	-	85	-		
	$\theta_y$	$\phi = 90^\circ, \text{CR} \geq 10$	-	85	-		
	$\theta_{y'}$	$\phi = 270^\circ, \text{CR} \geq 10$	-	85	-		
Color Chromaticity	Red	X	0.60	0.65	0.70	-	Note 6
		Y	0.27	0.32	0.37		
	Green	X	0.29	0.34	0.39		
		Y	0.55	0.60	0.65		
	Blue	X	0.10	0.15	0.20		
		Y	0.04	0.09	0.14		
	White	X	0.27	0.32	0.37		
		Y	0.30	0.35	0.40		

Note 1: The brightness is measured from the panel center point, P5 in Fig. 6.2, for the typical value.

Note 2: The brightness uniformity is calculated by the equation as below:

$$\text{Brightness uniformity} = \frac{\text{Min. Brightness}}{\text{Max. Brightness}} \times 100\%$$

which is based on the brightness values of the 9 points in active area measured by BM-5 as shown in Fig. 6.2.

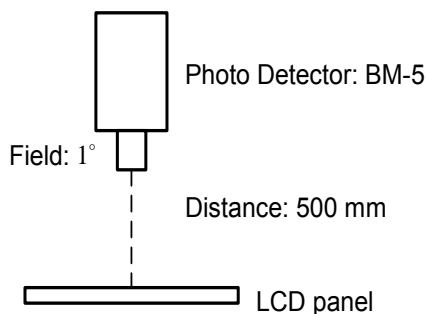

Fig 6.1

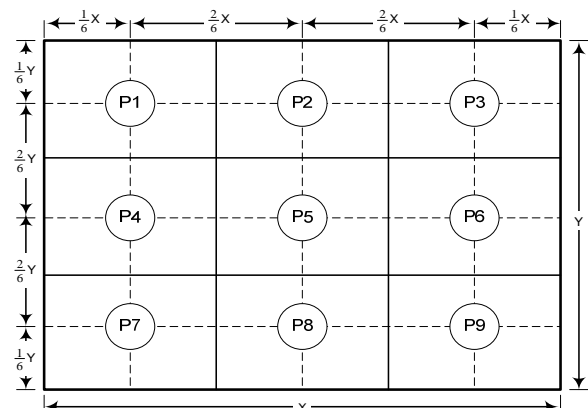

Fig 6.2

Note 3: The Contrast Ratio is measured from the center point of the panel, P5, and defined as the following equation:

$$CR = \frac{\text{Brightness of White}}{\text{Brightness of Black}}$$

Note 4: The definition of response time is shown in Fig. 6.3. The rising time is the period from 10% brightness to 90% brightness when the data is from black to white. Oppositely, Falling time is the period from 90% brightness falling to 10% brightness.

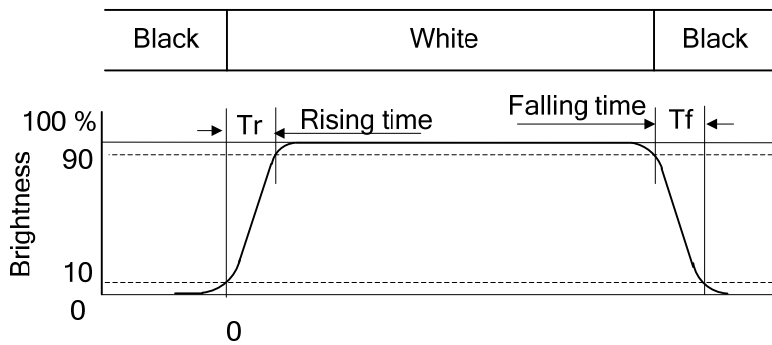

Fig 6.3

Note 5: The definition of viewing angle is shown in Fig. 6.4. Angle  $\phi$  is used to represent viewing directions, for instance,  $\phi = 270^\circ$  means 6 o'clock, and  $\phi = 0^\circ$  means 3 o'clock. Moreover, angle  $\theta$  is used to represent viewing angles from axis Z toward plane XY.

The display is super wide viewing angle version;  $85^\circ$  viewing angle can be obtained from each viewing direction.

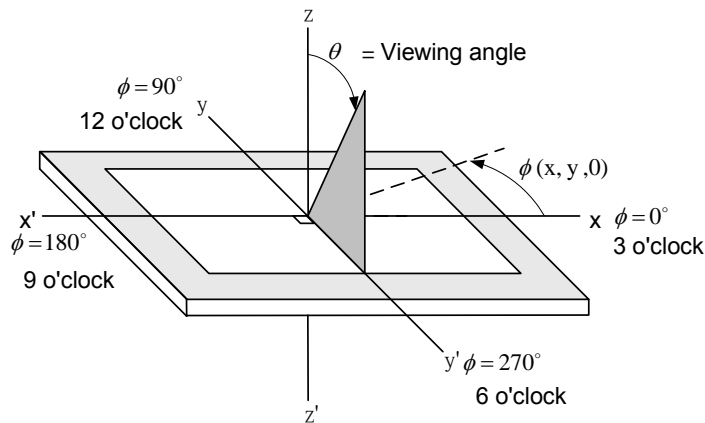
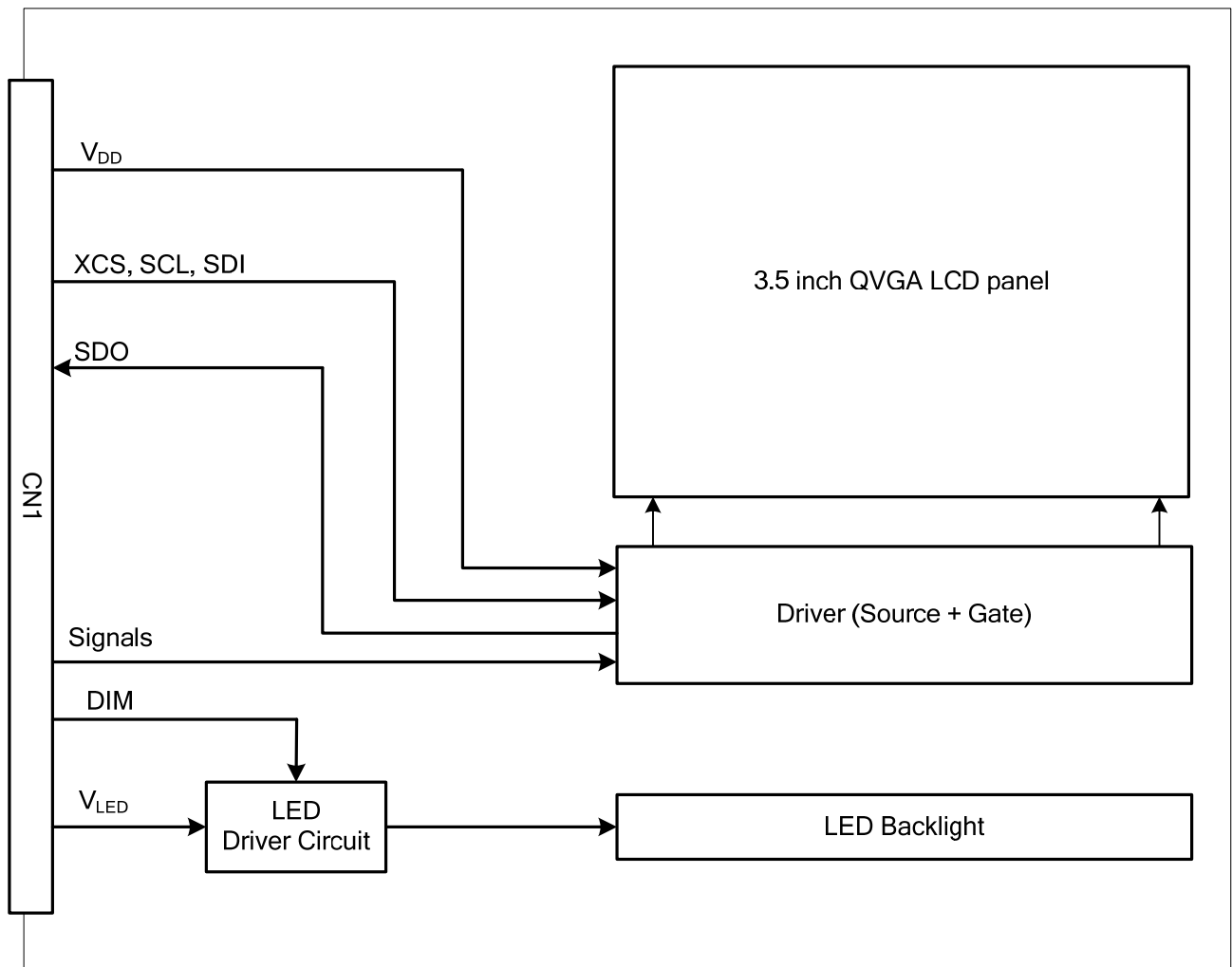

Fig 6.4

Note 6: The color chromaticity is measured from the center point of the panel, P5, as shown in Fig. 6.2.

## 7. BLOCK DIAGRAM



Note 1: Signals are DCLK, Vsync, Hsync, DE and RGB data bus.

## 8. RELIABILITY TESTS

Test Item	Condition	
High Temperature	1) Operating 2) 70°C	240 hrs
Low Temperature	1) Operating 2) -20°C	240 hrs
High Temperature	1) Storage 2) 80°C	240 hrs
Low Temperature	1) Storage 2) -30°C	240 hrs
Heat Cycle	1) Operating 2) -20°C~70°C 3) 3hrs~1hr~3hrs	240 hrs
Thermal Shock	1) Non-Operating 2) -30°C ↔ 80°C 3) 0.5 hr ↔ 0.5 hr	240 hrs
High Temperature & Humidity	1) Operating 2) 40°C & 85%RH 3) Without condensation	240 hrs (Note 3)
Vibration	1) Non-Operating 2) 20~200 Hz 3) 2G 4) X, Y, and Z directions	1 hr for each direction
Mechanical Shock	1) Non-Operating 2) 10 ms 3) 50G 4) ±X, ±Y and ±Z directions	Once for each direction
ESD	1) Operating 2) Tip: 150 pF, 330 Ω 3) Air discharge for glass: ± 8KV 4) Contact discharge for metal frame: ± 8KV	1) Glass: 9 points 2) Metal frame: 8 points (Note 4)

Note 1: Display functionalities are inspected under the conditions defined in the specification after the reliability tests.

Note 2: The display is not guaranteed for use in corrosive gas environments.

Note 3: Under the condition of high temperature & humidity, if the temperature is higher than 40°C, the humidity needs to be reduced as Fig. 8.1 shown.

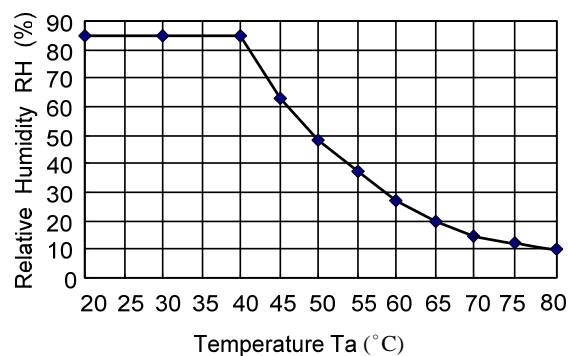

Fig. 8.1

Note 4: All pins of LCD interface (CN1) have been tested by ± 100V contact discharge of ESD under non-operating condition.

## 9. LCD INTERFACE

### 9.1 INTERFACE PIN CONNECTIONS

The display interface connector is FA5S050HP1 made by JAE (Thickness:  $0.3 \pm 0.05\text{mm}$ ; Pitch:  $0.5 \pm 0.05\text{mm}$ ) and more details of the connector are shown in the section of outline dimension.

Pin assignment of LCD interface is as below:

Pin No.	Signal	Function	Pin No.	Signal	Function
1	V <sub>DD</sub>	Power Supply for Logic	26	G2	Green Data
2	V <sub>DD</sub>		27	G1	
3	V <sub>SS</sub>	GND	28	G0	
4	V <sub>SS</sub>		29	V <sub>SS</sub>	GND
5	Vsync	Vertical Synchronous Signal	30	B7	Blue Data
6	DE	Timing Signal for Data	31	B6	
7	V <sub>SS</sub>	GND	32	B5	
8	DCLK	Dot Clock	33	B4	
9	V <sub>SS</sub>	GND	34	B3	
10	Hsync	Horizontal Synchronous Signal	35	B2	
11	V <sub>SS</sub>	GND	36	B1	
12	R7	Red Data	37	B0	
13	R6		38	V <sub>SS</sub>	GND
14	R5		39	XCS	Chip Select Signal
15	R4		40	SCL	Serial Clock
16	R3		41	SDI	Serial Data input
17	R2		42	SDO	Serial Data output
18	R1		43	V <sub>SS</sub>	GND
19	R0		44	V <sub>LED+</sub>	12 VDC
20	V <sub>SS</sub>	GND	45	V <sub>LED+</sub>	
21	G7	Green Data	46	V <sub>LED-</sub>	GND
22	G6		47	V <sub>LED-</sub>	
23	G5		48	DIM	Brightness Control ; Note1
24	G4		49	NC	No Connection
25	G3		50	NC	

Note 1: Normal brightness: 0V or 0% PWM duty; Brightness control: 0V to 3.3V DC or 0% to 100% PWM duty.

## 9.2 FUNCTIONS

This LCD module is equipped with two kind of interface used for transferring of command data and pixel data.

### 1) MPU serial interface

Serial bus with MPU control for transferring of command data and parameter data.

### 2) RGB interface

RGB data (R: 8bit, G: 8bit, B: 8bit) and Hsync, Vsync, DCLK and DE for transferring of display-content.

### MPU serial interface

MPU serial interface is performed by four signal lines

XCS	Chip select signal
SCL	Serial transfer clock signal
SDI	Serial input data signal (latched by rising edge of SCL)
SDO	Serial output data signal (data output during SCL = L)

Command data and parameter data are possible by using the following four pins: XCS, SCL, SDI, SDO.

#### <Data Write Method>

It is necessary to keep XCS=L during data transferring operation. After 9bit data transferred, then XCS need pull high.

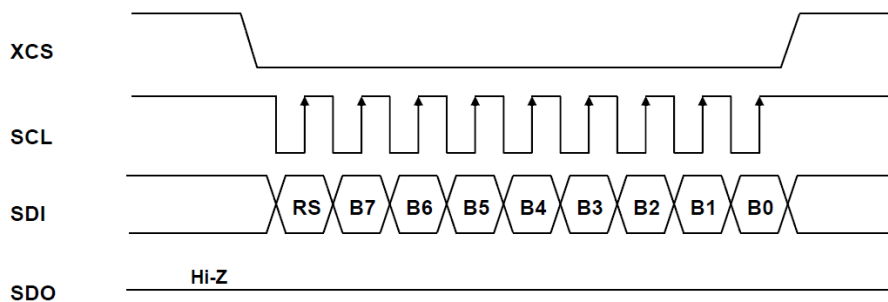

RS	B[7:0]
0	Command data
1	Parameter data

#### <Data Read Method>

A dummy clock is required before valid data reading as described in the following chart.

It is necessary to keep XCS = L during data reading operation. After all data received, XCS need pull high.

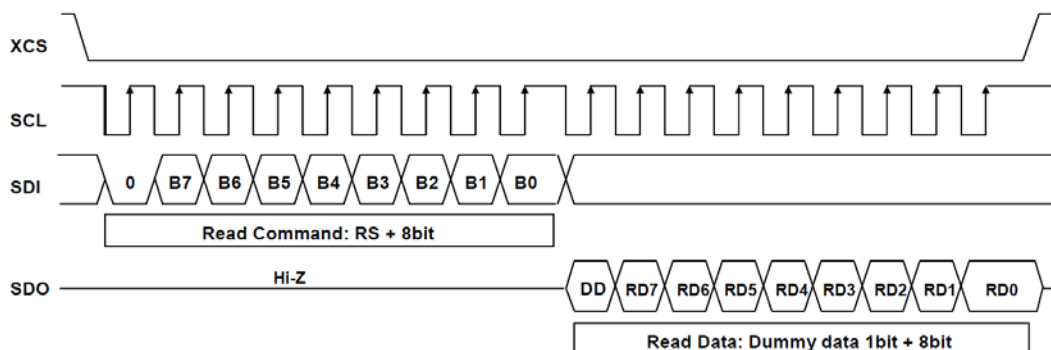

## Command List

No.	Command	Hex	B7	B6	B5	B4	B3	B2	B1	B0	Function	Parameter
1	NOP	00h	0	0	0	0	0	0	0	0	No operation	No
2	SWRESET	01h	0	0	0	0	0	0	0	1	Software reset	No
3	SLPIN	10h	0	0	0	1	0	0	0	0	Sleep in	No
4	SLPOUT	11h	0	0	0	1	0	0	0	1	Sleep out	No
5	DISINOFF	20h	0	0	1	0	0	0	0	0	Grayscale inversion off	No
6	INVON	21h	0	0	1	0	0	0	0	1	Grayscale inversion on	No
7	GAMSET	26h	0	0	1	0	0	1	1	0	Select gamma curve	Yes (1Byte)
8	DISOFF	28h	0	0	1	0	1	0	0	0	Display off	No
9	DISON	29h	0	0	1	0	1	0	0	1	Display on	No
10	COLMOD	3Ah	0	0	1	1	1	0	1	0	Select color depth	Yes (1Byte)
11	MADCTL	36h	0	0	1	1	0	1	1	0	Address control	Yes (1Byte)
12	RDDID1	DAh	1	1	0	1	1	0	1	0	Read ID1 data	Read data 1Byte

### (1) NOP

Command: 1 Parameter: 0

This command does not affect the operation or other effect to the LCD module (visual).

Command	Hex	B7	B6	B5	B4	B3	B2	B1	B0	Description
NOP	00h	0	0	0	0	0	0	0	0	No operation

### (2) SWRESET

Command: 1 Parameter: 0

This command resets TFTLCD module by software. This command should be entered at SPLIN state.

Command	Hex	B7	B6	B5	B4	B3	B2	B1	B0	Description
SWRESET	01h	0	0	0	0	0	0	0	1	Software reset

### (3) SLPIN

Command: 1 Parameter: 0

This command is used to TFTLCD module to the sleep state. When in sleep state, the oscillating circuit and the power circuit are suspended. After using this command, the power supply voltage ( $V_{DD}$ ) must be maintained for more than 200ms.

Command	Hex	B7	B6	B5	B4	B3	B2	B1	B0	Description
SLPIN	10h	0	0	0	1	0	0	0	0	Sleep in

The default setting SLPIN state.

#### (4) SLPOUT

Command: 1 Parameter: 0

This command is used to set TFTLCD module to quit the sleep state. By entering this command, the oscillating circuit and the power circuit start to operation. Output voltages of the power circuit are stabilized after 120ms or less from this command. After using this command, it is necessary to wait more than 10ms until entering next command.

Command	Hex	B7	B6	B5	B4	B3	B2	B1	B0	Description
SLPOUT	11h	0	0	0	1	0	0	0	1	Sleep out

The default setting is SLPIN state.

#### (5) DISINOFF

Command: 1 Parameter: 0

This command allows inversion off display.

Command	Hex	B7	B6	B5	B4	B3	B2	B1	B0	Description
DISINOFF	20h	0	0	1	0	0	0	0	0	Grayscale inversion off

The default setting is DISINOFF state.

#### (6) INVON

Command: 1 Parameter: 0

This command allows inverse the display without having to update the content.

Command	Hex	B7	B6	B5	B4	B3	B2	B1	B0	Description
INVON	21h	0	0	1	0	0	0	0	1	Grayscale inversion on

The default setting is DISINOFF state.

#### (7) GAMSET

Command: 1 Parameter: 1

This command and the subsequent parameter are used to select the gamma curve.

Command	Hex	B7	B6	B5	B4	B3	B2	B1	B0	Description
GAMSET	26h	0	0	1	0	0	1	1	0	Grayscale inversion on
P1	00h	0	0	0	0	0	0	0	0	

#### (8) DISOFF

Command: 1 Parameter: 0

This command makes the display a blank.

Command	Hex	B7	B6	B5	B4	B3	B2	B1	B0	Description
DISOFF	28h	0	0	1	0	1	0	0	0	Display off

The default setting is DISOFF state.

(9) DISON

Command: 1 Parameter: 0

This command turns on the display.

As for the command input order, please refer to Recommended Sequence.

Command	Hex	B7	B6	B5	B4	B3	B2	B1	B0	Description
DISON	29h	0	0	1	0	1	0	0	1	Display on

The default setting is DISOFF state.

(10) COLMOD

Command: 1 Parameter: 1

This command and the subsequent parameter are used to select the color depth.

Command	Hex	B7	B6	B5	B4	B3	B2	B1	B0	Description
COLMOD	3Ah	0	0	1	1	1	0	1	0	Select color depth
P1	70h	0	1	1	1	0	0	0	0	

(11) MADCTL

Command: 1 Parameter: 1

This command and the subsequent parameter are used to settle the display direction.

Command	Hex	B7	B6	B5	B4	B3	B2	B1	B0	Description
MADCTL	36h	0	0	1	1	0	1	1	0	Address control
P1		P17	P16	0	0	0	0	0	0	

P17	P16	Display Direction
0	0	Case 1
1	1	Case 2

→ Gate Scan Direction

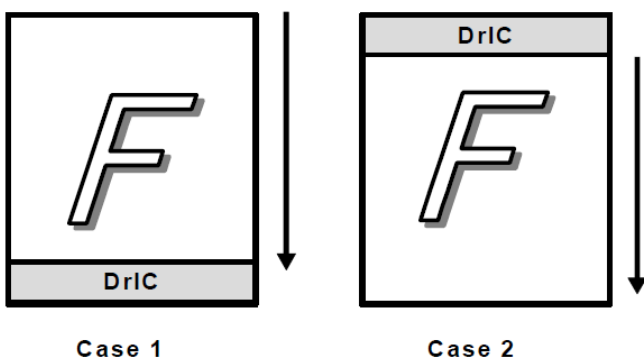

## (12) RDDID1

Command: 1 Parameter: 1

This command is used to read the ID1 data that is written into the internal ROM.

Command	Hex	B7	B6	B5	B4	B3	B2	B1	B0	Description
RDDID1	DAh	1	1	0	1	1	0	1	0	Read ID1 data
RD[7:0]		RD7	RD6	RD5	RD4	RD3	RD2	RD1	RD0	ID1 data = 00h

### AC CHARACTERISTICS of MPU Serial interface

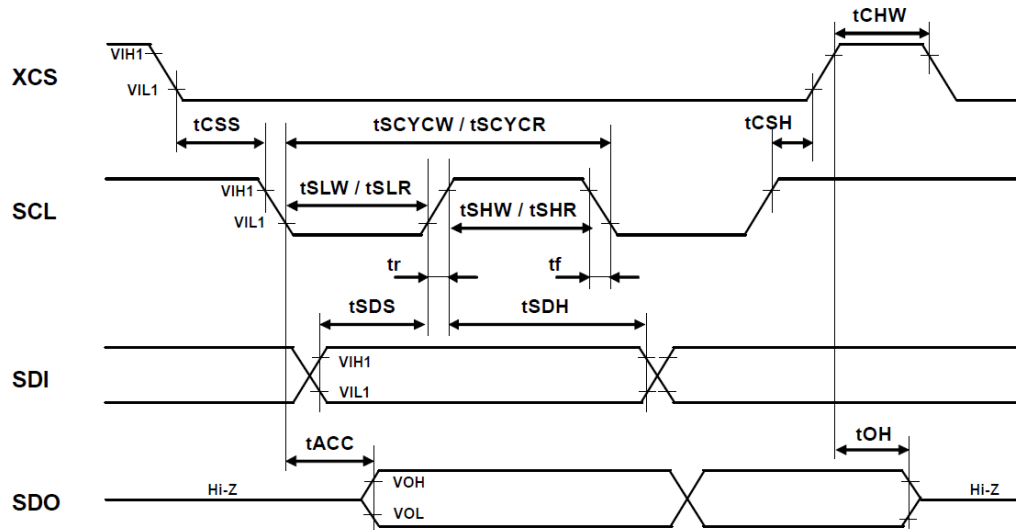

Signal	Symbol	Parameter	Min.	Max.	Unit	Description
XCS	tCSS	Chip select signal set up time	40	-	ns	*1, *2
	tCSH	Chip select signal hold time	80	-	ns	
	tCHW	Chip select signal high pulse width	40	-	ns	
SCL (Write)	tSCYCW	Write clock cycle time (tr, tf = 100ns)	400	-	ns	
	tSHW	Write clock high pulse width	100	-	ns	
	tSLW	Write clock low pulse width	100	-	ns	
SCL (Read)	tSCYCR	Read clock cycle time (tr, tf = 100ns)	450	-	ns	
	tSHR	Read clock high pulse width	125	-	ns	
	tSLR	Read clock low pulse width	125	-	ns	
SDI	tSDS	Data set up time	40	-	ns	
	tSDH	Data hold time	40	-	ns	
SDO	tACC	Read data access time	-	120	ns	*3, *4
	tOH	Read data disable time	15	-	ns	

Voltage of  $V_{DD}$  is in range of 5.1 LCD CHARACTERISTICS ambient temperature is in a range of operating temperature.

\*1: The rise and fall times of all input signals ( $t_r$ ,  $t_f$ ) are equal or less than 100ns.

\*2: For timing of all input signals, they are using 30% and 70% of  $V_{DD}$  as the base reference.

\*3: For timing of all output signals, they are set using 20% and 80% of  $V_{DD}$  as the base reference.

\*4: Measurement condition  $CL = 100pF$ .

## Recommended Sequence

Design a command sequence and intervals

Power on sequence

Command		Hex Data
Power-ON ( $V_{DD}$ )		
Wait more than 2ms		
Start to input control signals (Vsync, Hsync, DE, DCLK, Red[7:0], Green[7:0], Blue[7:0])		
Wait more than 0ms		
COLMOD	CMD	3Ah
	P1	70h
GAMSET	CMD	26h
	P1	00h
MADCTL	CMD	36h
	P1	C0h
SLPOUT	CMD	11h
Wait more than 120ms		
DISON	CMD	29h

Power off sequence

Command		Hex Data
SLPIN	CMD	10h
Wait more than 200ms		
Stop the control signals (Vsync, Hsync, DE, DCLK, Red[7:0], Green[7:0], Blue[7:0])		
Wait more than 0ms		
Wait more than 0ms		
Power-OFF ( $V_{DD}$ )		

Refresh sequence

This sequence should be implemented continuously in order to recover the display error due to noise etc.

Command		Hex Data
COLMOD	CMD	3Ah
	P1	70h
GAMSET	CMD	26h
	P1	00h
MADCTL	CMD	36h
	P1	C0h
DISINOFF	CMD	20h
DISON	CMD	29h
SLPOUT	CMD	11h
Wait more than 10ms until entering next command		

### 9.3 TIMING CHART

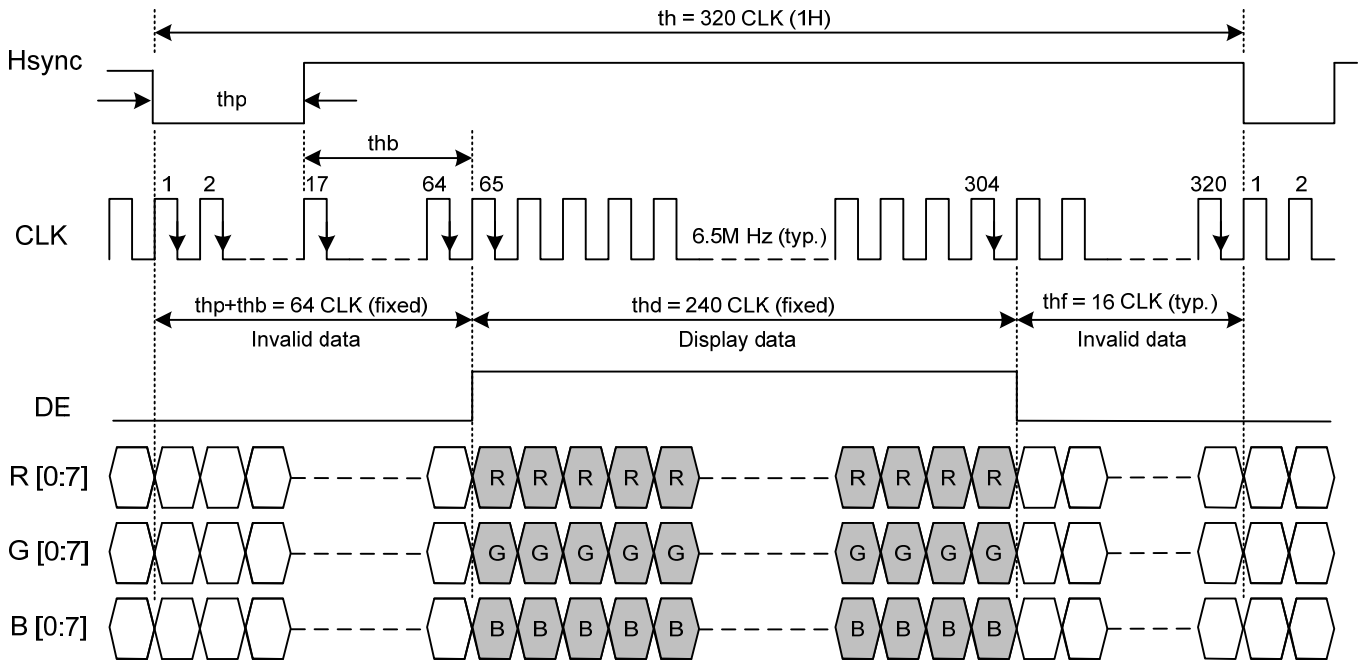

Fig. 9.1 Horizontal Timing of Synchronous Mode

Note 1: CLK's falling edge is the time to latch data and count ( $thp + thb$ ), therefore, data sending and Hsync's falling edge should start when CLK's rise edge.

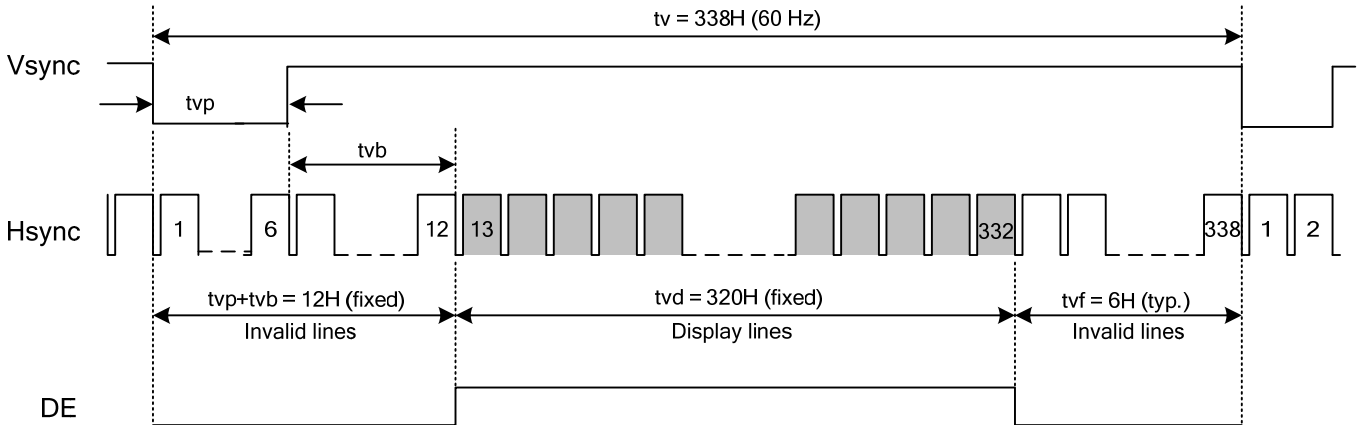

Fig. 9.2 Vertical Timing of Synchronous Mode

Note 2: Vsync's falling edge needs to start with Hsync's falling edge simultaneously to count ( $tvp + tvb$ ).

## 9.4 TIME TABLE

The column of timing sets including minimum, typical, and maximum as below are based on the best optical performance, frame frequency (Vsync) = 60 Hz to define. If 60 Hz is not the aim to set, 54~66 Hz for Vsync is recommended to apply for better performance by other parameter combination as the definitions in section 5.1.

### A. SYNCHRONOUS MODE

	Item	Symbol	Min.	Typ.	Max.	Unit
Hsync	CLK Frequency	fclk	6.0	6.5	7.0	M Hz
	Display Data	thd	240	240	240	CLK
	Cycle Time	th	296	320	346	
	Pulse Width	thp	16	16	16	
	Pulse Width and Back Porch	thp + thb	40	64	90	
	Front Porch	thf	16	16	16	
Vsync	Display Line	tvd	320	320	320	H
	Cycle Time	tv	338	338	338	
	Pulse Width	tvp	6	6	6	
	Pulse Width and Back Porch	tvp + tvb	12	12	12	
	Front Porch	tvf	6	6	6	

### B. CLOCK AND DATA INPUT TIMING

	Item	Symbol	Min.	Typ.	Max.	Unit
CLK	Duty	Tcwh	45	50	55	%
	Cycle Time	Tcph	143	154	166	ns
Vsync	Setup Time	Tvsu	15	-	-	
	Hold Time	Tvhd	15	-	-	
Hsync	Setup Time	Thsu	15	-	-	
	Hold Time	Thhd	15	-	-	
Data	Setup Time	Tdsu	15	-	-	
	Hold Time	Tdhd	15	-	-	

## 9.5 POWER SEQUENCE

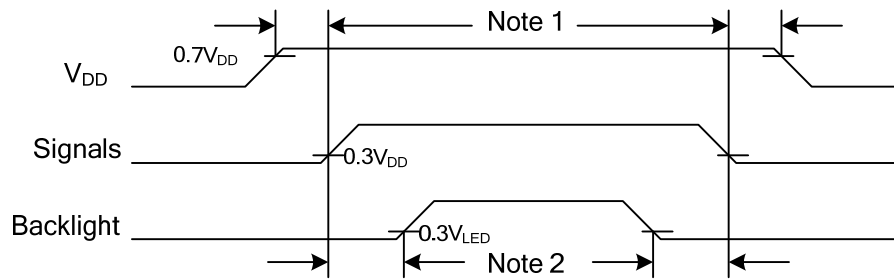

Note 1: In order to avoid any damages,  $V_{DD}$  has to be applied before all other signals. The opposite is true for power Off where  $V_{DD}$  has to be remained on until all other signals have been switch off. The recommended time period is 1 second. Hot plugging might cause display damage due to incorrect power sequence, please pay attention on interface connecting before power on.

Note 2: In order to avoid showing uncompleted patterns in transient state. It is recommended that switching the backlight on is delayed for 1 second after the signals have been applied. The opposite is true for power Off where the backlight has to be switched off 1 second before the signals are removed.

## 9.6 DATA INPUT for DISPLAY COLOR

Input color		Red Data								Green Data								Blue Data							
		R7	R6	R5	R4	R3	R2	R1	R0	G7	G6	G5	G4	G3	G2	G1	G0	B7	B6	B5	B4	B3	B2	B1	B0
		MSB				LSB				MSB				LSB				MSB				LSB			
Basic Color	Black	0	0	0	0	0	0	0	0	0	0	0	0	0	0	0	0	0	0	0	0	0	0	0	0
	Red(255)	1	1	1	1	1	1	1	1	0	0	0	0	0	0	0	0	0	0	0	0	0	0	0	0
	Green(255)	0	0	0	0	0	0	0	0	1	1	1	1	1	1	1	1	0	0	0	0	0	0	0	0
	Blue(255)	0	0	0	0	0	0	0	0	0	0	0	0	0	0	0	0	1	1	1	1	1	1	1	1
	Cyan	0	0	0	0	0	0	0	0	1	1	1	1	1	1	1	1	1	1	1	1	1	1	1	1
	Magenta	1	1	1	1	1	1	1	1	0	0	0	0	0	0	0	0	1	1	1	1	1	1	1	1
	Yellow	1	1	1	1	1	1	1	1	1	1	1	1	1	1	1	1	0	0	0	0	0	0	0	0
	White	1	1	1	1	1	1	1	1	1	1	1	1	1	1	1	1	1	1	1	1	1	1	1	1
Red	Black	0	0	0	0	0	0	0	0	0	0	0	0	0	0	0	0	0	0	0	0	0	0	0	0
	Red(1)	0	0	0	0	0	0	0	1	0	0	0	0	0	0	0	0	0	0	0	0	0	0	0	0
	Red(2)	0	0	0	0	0	0	1	0	0	0	0	0	0	0	0	0	0	0	0	0	0	0	0	0
	:	:	:	:	:	:	:	:	:	:	:	:	:	:	:	:	:	:	:	:	:	:	:	:	:
	Red(253)	1	1	1	1	1	1	0	1	0	0	0	0	0	0	0	0	0	0	0	0	0	0	0	0
	Red(254)	1	1	1	1	1	1	1	0	0	0	0	0	0	0	0	0	0	0	0	0	0	0	0	0
	Red(255)	1	1	1	1	1	1	1	1	0	0	0	0	0	0	0	0	0	0	0	0	0	0	0	0
Green	Black	0	0	0	0	0	0	0	0	0	0	0	0	0	0	0	0	0	0	0	0	0	0	0	0
	Green(1)	0	0	0	0	0	0	0	0	0	0	0	0	0	0	1	0	0	0	0	0	0	0	0	
	Green(2)	0	0	0	0	0	0	0	0	0	0	0	0	0	1	0	0	0	0	0	0	0	0	0	
	:	:	:	:	:	:	:	:	:	:	:	:	:	:	:	:	:	:	:	:	:	:	:	:	
	Green(253)	0	0	0	0	0	0	0	0	1	1	1	1	1	1	0	1	0	0	0	0	0	0	0	
	Green(254)	0	0	0	0	0	0	0	0	1	1	1	1	1	1	0	0	0	0	0	0	0	0	0	
	Green(255)	0	0	0	0	0	0	0	0	1	1	1	1	1	1	1	0	0	0	0	0	0	0	0	
Blue	Black	0	0	0	0	0	0	0	0	0	0	0	0	0	0	0	0	0	0	0	0	0	0	0	0
	Blue(1)	0	0	0	0	0	0	0	0	0	0	0	0	0	0	0	0	0	0	0	0	0	0	0	1
	Blue(2)	0	0	0	0	0	0	0	0	0	0	0	0	0	0	0	0	0	0	0	0	0	0	1	0
	:	:	:	:	:	:	:	:	:	:	:	:	:	:	:	:	:	:	:	:	:	:	:	:	:
	Blue(253)	0	0	0	0	0	0	0	0	0	0	0	0	0	0	0	0	1	1	1	1	1	1	0	1
	Blue(254)	0	0	0	0	0	0	0	0	0	0	0	0	0	0	0	0	1	1	1	1	1	1	1	0
	Blue(255)	0	0	0	0	0	0	0	0	0	0	0	0	0	0	0	0	1	1	1	1	1	1	1	1



# 11. TOUCH PANEL

The type of touch panel used on this display is resistive, analog, 4-wire and film on glass, and more characteristics are shown as below:

## 11.1 OPERATING CONDITIONS

Item	Specification	Remarks
Operating Voltage	5VDC	7V MAX

## 11.2 ELECTRICAL CHARACTERISTICS

Item	Specification	Remarks
Resistance Between Terminal	XR-XL	100~750Ω
	YU-YL	310~950Ω
Insulation Resistance	X-Y	20MΩ min. At 25V DC
Linearity	X	±1.5% max.
	Y	±1.5% max.
Chattering	10ms max.	-

Note 1: The test conditions and equipments of linearity are as below:

- Material of pen: poly-acetal resin
- End shape: R 0.8 mm
- Test force: 80 g
- Pitch: 10 mm
- Test area is shown in Fig. 11.1

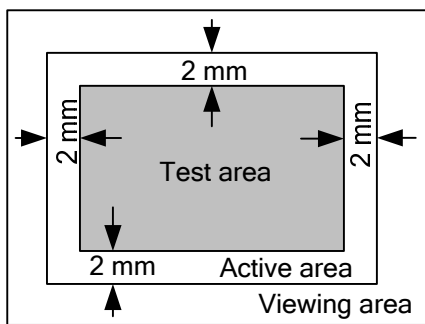

Fig. 11.1

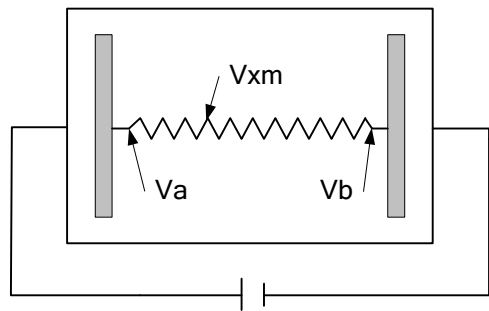

Fig. 11.2

As shown in Fig. 11.2, applying voltage meter to measure Va, Vb and Vxm, where Va is the maximum voltage in the active area; Vb is the minimum voltage in the active area; Vxm is the measured voltage of point x selected by random. Afterwards, the linearity can be calculated by following equation:

$$\text{Linearity} = \frac{|V_{xi} - V_{xm}|}{V_a - V_b} \times 100\%$$

where Vxi is the idea voltage of point x.

The method to measure the linearity of Y-axis is the same as above.

### 11.3 MECHANICAL CHARACTERISTICS

Item	Specification	Remarks
Pen Input Pressure	20~80g	R0.8, Polyacetal Pen
Surface Hardness	3H min.	JIS K-5600-5-4

### 11.4 OPTICAL CHARACTERISTICS

Item	Specification	Remarks
Transmittance	80% min.	-

### 11.5 SAFETY AND ATTENTIONS

- 1) Do not put heavy shock or stress on the touch panel.
- 2) Please use soft cloth or absorbent cotton with ethanol to clean the touch panel by gently wiping. Moreover, please wipe it by horizontal or vertical direction instead of circling to prevent leaving scars on the touch panel's surface.
- 3) Do not use any harmful chemicals such as acetone, toluene, and isopropyl alcohol to clean the display's surface.
- 4) UV protection is recommended to avoid the possibility of performance degrading when touch panel is likely applied under UV environment for a long period of time.

## 12. APPEARANCE STANDARD

The appearance inspection is performed in a room around 500~1000 lx based on the conditions as below:

- The distance between inspector's eyes and display is 30 cm.
- The viewing zone is defined with angle  $\theta$  shown in Fig.12.1 The inspection should be performed within  $45^\circ$  when display is shut down. The inspection should be performed within  $5^\circ$  when display is power on.

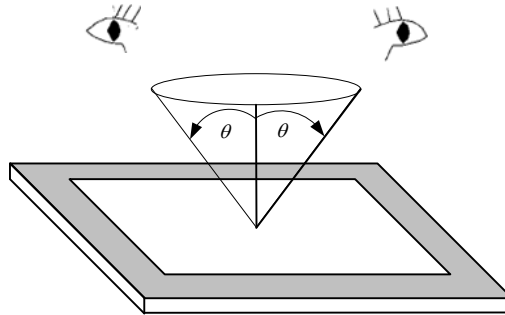

Fig. 12.1

### 12.1 THE DEFINITION OF LCD ZONE

LCD panel is divided into 2 areas as shown in Fig.12.2 for appearance specification in next section. A zone is the LCD active area (dot area); B zone is the area between A zone and metal frame.

In terms of housing design, B zone is the recommended window area customers' housing should be located in.

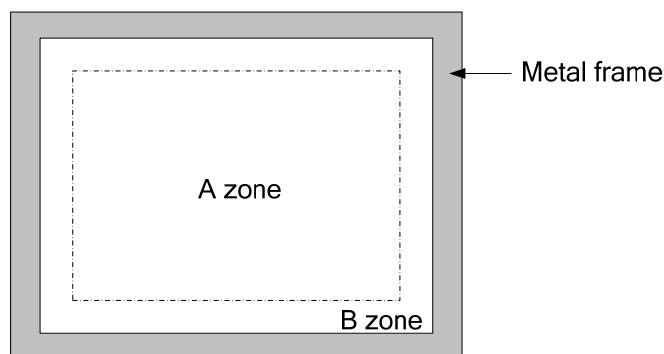

Fig. 12.2

## 12.2 LCD APPEARANCE SPECIFICATION

The specification as below is defined as the amount of unexpected phenomenon or material in different zones of LCD panel. The definitions of length, width and average diameter using in the table are shown in Fig.12.3 and Fig.12.4.

Item	Criteria			Applied zone
Scratches	Length / L(mm)	Width / W(mm)	Maximum number Acceptable	A,B
	$L \leq 2.0$	$W \leq 0.03$	Ignored	
	$L \leq 2.0$	$0.03 < W \leq 0.05$	4	
	$L > 2.0$	$0.05 < W$	None	
Dent	Serious one is not allowed.			A
Wrinkles in Polarizer	Serious one is not allowed.			A
Bubbles on Polarizer	Average diameter / D(mm)		Maximum number Acceptable	A
	$D \leq 0.3$		2	
	$0.3 < D$		None	
1) Stains 2) Foreign Materials 3) Dark Spot	Filamentous (Line shape)			A,B
	Length / L(mm)	Width / W(mm)	Maximum number Acceptable	
	$L < 2.0$	$W \leq 0.05$	4	
	$L \leq 1.0$	$0.05 < W \leq 0.1$	2	
	Round (Dot shape)			A,B
	Average diameter / D(mm)		Maximum number acceptable	
	$D \leq 0.15$		6	
	$0.15 < D \leq 0.2$		4	
	$0.2 < D$		None	
	In total		Filamentous + Round=9	
Those wiped out easily are acceptable.				
Dot-Defect (Note 1)	Type		Maximum number acceptable	A,B
	Bright dot-defect	1 dot	0	
	Dark dot-defect	1 dot	4	
		2 dots	1(sets)	
		In total	4	
In total		4		

### 12.3 TOUCH PANEL APPEARANCE SPECIFICATION

The specification as below is defined by the amount of unexpected material in different zones of touch panel.

Item	Criteria			Applied zone
Scratches	Length / L(mm)	Width / W(mm)	Maximum number acceptable	A,B
	$L > 2$	$W \leq 0.03$	None	
	$L \leq 2$		Ignored	
	$L \leq 2$	$0.03 < W \leq 0.05$	2 (Partial distance $\geq$ 20mm)	
	$L > 2$		None	
	-	$W > 0.05$	None	
Foreign Materials	Filamentous (Line shape)			A,B
	Length / L(mm)	Width / W(mm)	Maximum number acceptable	
	$L > 2$	$W \leq 0.03$	None	
	$L \leq 2$		Ignored	
	$L \leq 2$	$0.03 < W \leq 0.05$	2 (Partial distance $\geq$ 20mm)	
	$L > 2$		None	
	-	$W > 0.05$	None	
	Round (Dot shape)			A,B
	Average diameter / D(mm)	Minimum Space	Maximum number acceptable	
	$D < 0.1$	Partial distance $\geq$ 20mm if multiple partials appear	Ignored	
	$0.10 \leq D < 0.15$		2	
	$0.15 \leq D < 0.25$		1	
$0.25 \leq D$	None			

The limitation of glass flaw occurred on touch panel is defined in the table as below.

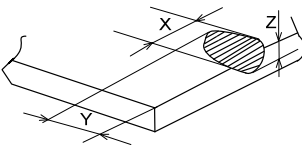
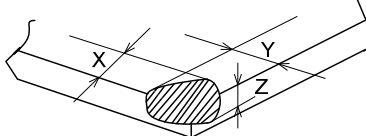
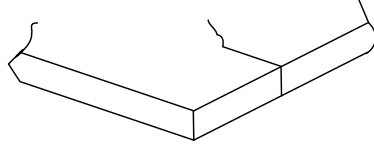
Item	Specifications	Maximum number acceptable
Edge flaw		$X \leq 5.0 \text{ mm}$ $Y \leq 1.0 \text{ mm}$ $Z \leq \text{Thickness}$ 5
Corner flaw		$X \leq 2.0 \text{ mm}$ $Y \leq 2.0 \text{ mm}$ $Z \leq \text{Thickness}$ 2
Progressive flaw		- Not allowed

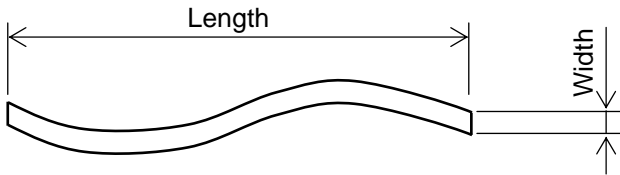

Fig 12.3

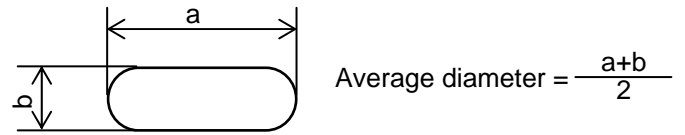
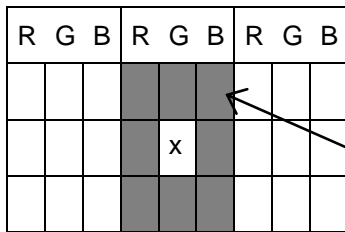

Fig.12.4

Note 1: The definitions of dot defect are as below:

- For bright dot-defect, showing black pattern, visible with 5% ND filter is defined.
- For dark dot-defect, showing white pattern, defect size over 1/2 dot area is defined.
- The definition of 1-dot-defect is the defect-dot, which is isolated and no adjacent defect-dot.
- The definition of adjacent dot is shown as Fig. 12.5.
- The density of dot defect is defined in the area within diameter  $\phi = 10\text{mm}$ .



The dots colored in gray are adjacent to defect - dot "X".

Fig 12.5

## 13. PRECAUTIONS

### 13.1 PRECAUTIONS of MOUNTING

1) Please refer to Fig. 13.1 for housing the display with touch panel into applications. The Fig. 13.1 shows some points as below:

- The cushion needs to be designed between housing and touch panel in order to avoid unexpected pressure to cause any wrong reactions, and the cushion should be located in the insulated area.
- The housing should not cover the active area of touch panel as the figure shown.

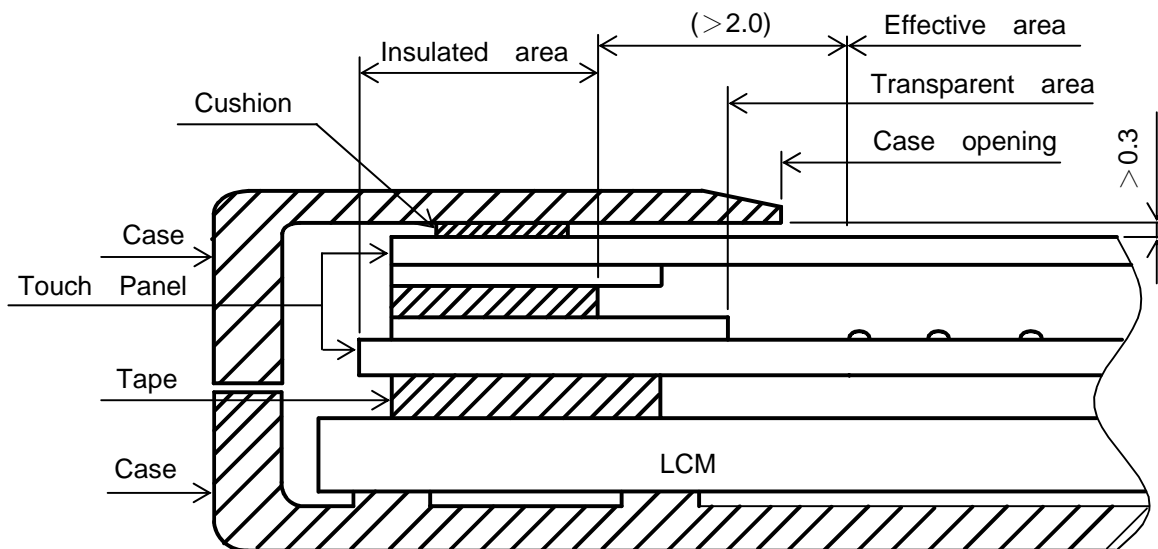

Fig 13.1

### 13.2 PRECAUTIONS of ESD

- 1) Before handling the display, please ensure your body has been connected to ground to avoid any damages by ESD. Also, do not touch display's interface directly when assembling.
- 2) Please remove the protection film very slowly before turning on the display to avoid generating ESD.

### 13.3 PRECAUTIONS of HANDLING

- 1) In order to keep the appearance of display in good condition, please do not rub any surfaces of the displays by sharp tools harder than 3H, especially touch panel, metal frame and polarizer.
- 2) Please do not pile the displays in order to avoid any scars leaving on the display. In order to avoid any injuries, please pay more attention for the edges of glasses and metal frame, and wear finger cots to protect yourself and the display before working on it.
- 3) Touching the display area or the terminal pins with bare hand is prohibited. This is because it will stain the display area and cause poor insulation between terminal pins, and might affect display's electrical characteristics furthermore.
- 4) Do not use any harmful chemicals such as acetone, toluene, and isopropyl alcohol to clean display's surfaces.
- 5) Please use soft cloth or absorbent cotton with ethanol to clean the display by gently wiping. Moreover, when wiping the display, please wipe it by horizontal or vertical direction instead of circling to prevent leaving scars on the display's surface, especially polarizer.

- 6) Please wipe any unknown liquids immediately such as saliva, water or dew on the display to avoid color fading or any permanently damages.
- 7) Maximum pressure to the surface of the display must be less than  $1,96 \times 10^4$  Pa. If the area of adding pressure is less than  $1 \text{ cm}^2$ , the maximum pressure must be less than 1.96N.

#### 13.4 PRECAUTIONS OF OPERATING

- 1) Please input signals and voltages to the displays according to the values defined in the section of electrical characteristics to obtain the best performance. Any voltages over than absolute maximum rating will cause permanent damages to this display. Also, any timing of the signals out of this specification would cause unexpected performance.
- 2) When the display is operating at significant low temperature, the response time will be slower than it at  $25 \text{ C}^\circ$ . In high temperature, the color will be slightly dark and blue compared to original pattern. However, these are temperature-related phenomenon of LCD and it will not cause permanent damages to the display when used within the operating temperature.
- 3) The use of screen saver or sleep mode is recommended when static images are likely for long periods of time. This is to avoid the possibility of image sticking.
- 4) Spike noise can cause malfunction of the circuit. The recommended limitation of spike noise is no bigger than  $\pm 100 \text{ mV}$ .

#### 13.5 PRECAUTIONS of STORAGE

If the displays are going to be stored for years, please be aware the following notices.

- 1) Please store the displays in a dark room to avoid any damages from sunlight and other sources of UV light.
- 2) The recommended long term storage temperature is between  $10 \text{ C}^\circ \sim 35 \text{ C}^\circ$  and 55%~75% humidity to avoid causing bubbles between polarizer and LCD glasses, and polarizer peeling from LCD glasses.
- 3) It would be better to keep the displays in the container, which is shipped from KOE, and do not unpack it.
- 4) Please do not stick any labels on the display surface for a long time, especially on the polarizer.

# 14. DESIGNATION of LOT MARK

1) The lot mark is showing in Fig.14.1. First 4 digits are used to represent production lot, T represented made in Taiwan, and the last 6 digits are the serial number.

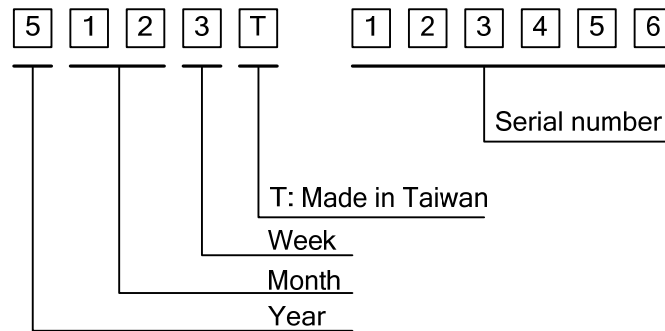

Fig. 14.1

2) The tables as below are showing what the first 4 digits of lot mark are shorted for.

Year	Lot Mark
2015	5
2016	6
2017	7
2018	8
2019	9

Month	Lot Mark	Month	Lot Mark
Jan.	01	Jul.	07
Feb.	02	Aug.	08
Mar.	03	Sep.	09
Apr.	04	Oct.	10
May	05	Nov.	11
Jun.	06	Dec.	12

Week	Lot Mark
1~7 days	1
8~14 days	2
15~21 days	3
22~28 days	4
29~31 days	5

3) Except letters I and O, revision number will be shown on lot mark and following letters A to Z.

4) The location of the lot mark is on the back of the display shown in Fig. 14.2.

Label example:

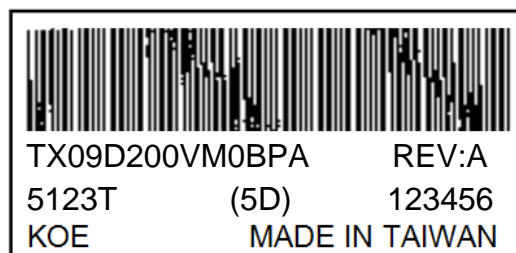

Fig. 14.2