

# KOE

---

## JDI Group

Kaohsiung Opto-Electronics Inc.

FOR MESSRS: \_\_\_\_\_

DATE: May 1<sup>st</sup> 2012

### CUSTOMER'S ACCEPTANCE SPECIFICATIONS

## ST12Q01L6ALAA

### Contents

No.	ITEM	SHEET No.	PAGE
1	COVER	7B64PS 2701-ST12Q01L6ALZZ-4	1-1/1
2	RECORD OF REVISION	7B64PS 2702-ST12Q01L6ALZZ-4	2-1/2~2/2
3	GENERAL SPECIFICATIONS	7B64PS 2703-ST12Q01L6ALZZ-4	3-1/1
4	ABSOLUTE MAXIMUM RATINGS	7B64PS 2704-ST12Q01L6ALZZ-4	4-1/1
5	ELECTRICAL CHARACTERISTICS	7B64PS 2705-ST12Q01L6ALZZ-4	5-1/2~2/2
6	OPTICAL CHARACTERISTICS	7B64PS 2706-ST12Q01L6ALZZ-4	6-1/3~3/3
7	BLOCK DIAGRAM	7B64PS 2707-ST12Q01L6ALZZ-4	7-1/1
8	INTERFACE TIMING CHART	7B64PS 2708-ST12Q01L6ALZZ-4	8-1/4~4/4
9	OUTLINE DIMENSIONS	7B64PS 2709-ST12Q01L6ALZZ-4	9-1/1
10	APPEARANCE STANDARD	7B64PS 2710-ST12Q01L6ALZZ-4	10-1/3~3/3
11	PRECAUTION IN DESIGN	7B64PS 2711-ST12Q01L6ALZZ-4	11-1/3~3/3
12	DESIGNATION OF LOT MARK	7B64PS 2712-ST12Q01L6ALZZ-4	12-1/1
13	PRECAUTION FOR USE	7B64PS 2713-ST12Q01L6ALZZ-4	13-1/1

ACCEPTED BY: \_\_\_\_\_

PROPOSED BY: 

## RECORD OF REVISION

DATE	SHEET No.	SUMMARY																							
May.28,'07	7B64PS 2704 – ST12Q01L6ALZZ-2 PAGE 4 - 1/1	4.2 ENVIRONMENTAL ABSOLUTE MAXIMUM RATINGS Added Operating Life : (40,000h)																							
	7B64PS 2705 – ST12Q01L6ALZZ-2 PAGE 5 - 2/2	5.2 ELECTRICAL CHARACTERISTICS OF LED BACKLIGHT Revised <table border="1" style="width: 100%; margin-bottom: 10px;"> <thead> <tr> <th>ITEM</th> <th>MIN.</th> <th>TYP.</th> <th>MAX.</th> </tr> </thead> <tbody> <tr> <td>Power Supply Voltage for LED</td> <td>(4.8)</td> <td>(5)</td> <td>(5.2)</td> </tr> <tr> <td>Power Supply Current for LED (Note1)</td> <td>-</td> <td>(140)</td> <td>-</td> </tr> </tbody> </table> <p style="text-align: center;">↓</p> <table border="1" style="width: 100%; margin-bottom: 10px;"> <thead> <tr> <th>ITEM</th> <th>MIN.</th> <th>TYP.</th> <th>MAX.</th> </tr> </thead> <tbody> <tr> <td>Power Supply Voltage for LED</td> <td>4.8</td> <td>5</td> <td>5.2</td> </tr> <tr> <td>Power Supply Current for LED (Note 1)</td> <td>-</td> <td>(80)</td> <td>-</td> </tr> </tbody> </table> <div style="display: flex; justify-content: space-around; align-items: flex-end;"> <div style="text-align: center;"> <p>Ambient Temperature vs. Allowable Forward Current</p> <p style="font-size: small;">Allowable Forward Current (mA/LED)</p> <p style="font-size: small;">Ambient Temperature Ta(°C)</p> </div> <div style="text-align: center;"> <p>→</p> </div> <div style="text-align: center;"> <p>Ambient Temperature vs. Allowable Forward Current</p> <p style="font-size: small;">Allowable Forward Current (mA/LED)</p> <p style="font-size: small;">Ambient Temperature Ta(°C)</p> </div> </div>	ITEM	MIN.	TYP.	MAX.	Power Supply Voltage for LED	(4.8)	(5)	(5.2)	Power Supply Current for LED (Note1)	-	(140)	-	ITEM	MIN.	TYP.	MAX.	Power Supply Voltage for LED	4.8	5	5.2	Power Supply Current for LED (Note 1)	-	(80)
ITEM	MIN.	TYP.	MAX.																						
Power Supply Voltage for LED	(4.8)	(5)	(5.2)																						
Power Supply Current for LED (Note1)	-	(140)	-																						
ITEM	MIN.	TYP.	MAX.																						
Power Supply Voltage for LED	4.8	5	5.2																						
Power Supply Current for LED (Note 1)	-	(80)	-																						
7B64PS 2712 – ST12Q01L6ALZZ-2 PAGE 12 - 1/1	12. DESIGNATION OF LOT MARK Added	<table border="1" style="width: 100%; margin-bottom: 10px;"> <thead> <tr> <th>REV No.</th> <th>ITEM</th> <th>Note</th> </tr> </thead> <tbody> <tr> <td style="text-align: center;">-</td> <td></td> <td></td> </tr> </tbody> </table> <p style="text-align: center;">↓</p> <table border="1" style="width: 100%;"> <thead> <tr> <th>REV No.</th> <th>ITEM</th> <th>Note</th> </tr> </thead> <tbody> <tr> <td style="text-align: center;">-</td> <td style="text-align: center;">-</td> <td style="text-align: center;">-</td> </tr> <tr> <td style="text-align: center;">A</td> <td>Operating Life (40,000h)</td> <td>7062T</td> </tr> </tbody> </table>	REV No.	ITEM	Note	-			REV No.	ITEM	Note	-	-	-	A	Operating Life (40,000h)	7062T								
	REV No.	ITEM	Note																						
-																									
REV No.	ITEM	Note																							
-	-	-																							
A	Operating Life (40,000h)	7062T																							
Sep.09,'10	7B64PS 2708 – ST12Q01L6ALZZ-3 PAGE 8 - 4/4	9.3 INTERNAL PIN CONNECTION Changed CN1 : Molex / 52103-1217→TOKUTSU TERMINAL/BL-113-12RU																							

## RECORD OF REVISION

DATE	SHEET No.	SUMMARY									
Sep.09,'10	7B64PS 2712 – ST12Q01L6ALZZ-3 PAGE 12 - 1/1	12. DESIGNATION OF LOT MARK Added <table border="1" style="margin-left: auto; margin-right: auto; border-collapse: collapse;"> <thead> <tr> <th style="width: 15%;">REV No.</th> <th style="width: 55%;">ITEM</th> <th style="width: 30%;">Note</th> </tr> </thead> <tbody> <tr> <td style="text-align: center;">B</td> <td style="text-align: center;">M's IC change</td> <td style="text-align: center;">PCN0762</td> </tr> <tr> <td style="text-align: center;">C</td> <td style="text-align: center;">CN1 Connector change</td> <td style="text-align: center;">PCN0802</td> </tr> </tbody> </table>	REV No.	ITEM	Note	B	M's IC change	PCN0762	C	CN1 Connector change	PCN0802
REV No.	ITEM	Note									
B	M's IC change	PCN0762									
C	CN1 Connector change	PCN0802									
May 01,'12	All pages	Company name changed: KAOHSIUNG HITACHI ELECTRONICS CO.,LTD. ↓ KAOHSIUNG OPTO-ELECTRONICS INC.									

### 3. GENERAL SPECIFICATIONS

(1) Part Name	ST12Q01L6ALZZ
(2) Module Size	129.6(W)mm x 92.6(H)mm x 7.5(D)mm
(3) Effective Area	100(W)mm min. x 75.5(H)mm min.
(4) Dot Size	0.285(W)mm x 0.285(H)mm
(5) Dot Pitch	0.3(W)mm x 0.3(H)mm
(6) Dot Number	320 (W) x 240 (H)
(7) Duty Ratio	1/240
(8) LCD Type	Transflective type F-B / W STN The upper polarizer is Glare Type.
(9) Viewing Direction	6 O'clock
(10) Viewing Angle	Wide Viewing Angle
(11) Operating Temperature	Wide Temperature Range
(12) Backlight Type	LED(Color : white)
(13) Weight	110g

## 4. ABSOLUTE MAXIMUM RATINGS

### 4.1 ELECTRICAL ABSOLUTE MAXIMUM RATINGS

VSS=0V:STANDARD

ITEM	SYMBOL	MIN.	MAX.	UNIT	REMARKS
Power Supply for Logic	VDD-VSS	0	6.5	V	
Power Supply for LC Drive	VDD-VEE	0	27.5	V	
Input Voltage	$V_i$	-0.3	VDD+0.3	V	Note1
Input Current	$I_i$	0	1	A	
Static Electricity	-	-	100	-	Note2

Note 1:  $\overline{DOFF}$ , FLM, CL1, CL2, D0~D3.

Note 2: Make certain you are grounded when handling LCM.

### 4.2 ENVIRONMENTAL ABSOLUTE MAXIMUM RATINGS

ITEM	OPERATING		STORAGE		REMARKS
	MIN.	MAX.	MIN.	MAX.	
Ambient Temperature	-20°C	70°C Note5	-30°C	80°C	Note 2,3,6
Humidity	Note1		Note1		Without Condensation
Vibration	-	2.45m/s <sup>2</sup> (0.25G)	-	11.76m/s <sup>2</sup> (1.2G) Note5	Note4
Shock	-	29.4m/s <sup>2</sup> (3 G)	-	490.0m/s <sup>2</sup> (50 G) Note5	X · Y · Z Directions
Corrosive Gas	Not Acceptable		Not Acceptable		
Operating Life Note8	(40,000 h) Note7		-		At 25°C, I <sub>LED</sub> =80mA max.

Note 1:  $T_a \leq 40^\circ\text{C}$  : 85%RH max.

$T_a > 40^\circ\text{C}$  : Absolute humidity must be lower than the humidity of 85%RH at 40°C.

Note 2:  $T_a$  at -20°C ---< 48h, at 60°C ---< 168h.

Note 3: Background color changes slightly depending on ambient temperature.

This phenomenon is reversible.

Higher LCD driving voltage is needed while operating at 0°C.

Note 4: 5Hz~100Hz(Except resonance frequency and X, Y, Z each direction within 1h)

Note 5: This module should be operated normally after finish the test.

Note 6: The response time will be slower under low temperature.

Note 7: When brightness reached 50% of initial brightness.

Note 8: Life time is estimated data.

## 5. ELECTRICAL CHARACTERISTICS

### 5.1 ELECTRICAL CHARACTERISTICS

ITEM	SYMBOL	CONDITION	MIN.	TYP.	MAX.	UNIT
Power Supply Voltage for Logic	VDD-VSS	-	3.0	5.0	5.25	V
Power Supply Voltage For LC Driving	VEE-VSS	-	-	-22.0	-	V
Input Voltage Note1	Vi	H LEVEL	0.8VDD	-	VDD	V
		L LEVEL	0	-	0.2VDD	V
Power Supply Current for Logic Note2	IDD	VDD-VSS=5.0V VEE-VSS=-22.0V	-	8.0	-	mA
Power Supply Current For LC Driving Note2	IEE	VDD-VSS=5.0V VEE-VSS=-22.0V	-	6.0	-	mA
Recommended LC Driving Voltage Note4	VDD-VEE	Ta=-20°C , $\phi=0^\circ$	-	-	-	V
		Ta=25°C , $\phi=0^\circ$	-	23.0	-	V
		Ta=70°C , $\phi=0^\circ$	-	-	-	V
Frame Frequency	fFLM	-	70	-	140	Hz

Note 1:  $\overline{\text{DOFF}}$  , FLM , CL1 , CL2 , D0~D3.

Note 2: fFLM=75HZ  
VDD-VEE=23.0V,Ta=25°C.

Note 3: Recommended LC driving voltage fluctuate about  $\pm 1.0V$  by each module.  
Test pattern is all "Q"

Note 4: Need to make sure of flickering and rippling of display when setting the frame frequency in your set.

## 5.2 ELECTRICAL CHARACTERISTICS OF LED BACKLIGHT

$T_a=25^{\circ}\text{C}$  (Backlight on)

ITEM	SYMBOL	CONDITION	MIN.	TYP.	MAX.	UNIT
Power Supply Voltage for LED	VLED	-	4.8	5	5.2	V
Power Supply Current for LED Note1	ILED	-	-	80	-	mA

Note 1 : The ILED changes depending on ambient temperature.

Ambient Temperature vs.  
Allowable Forward Current For LED

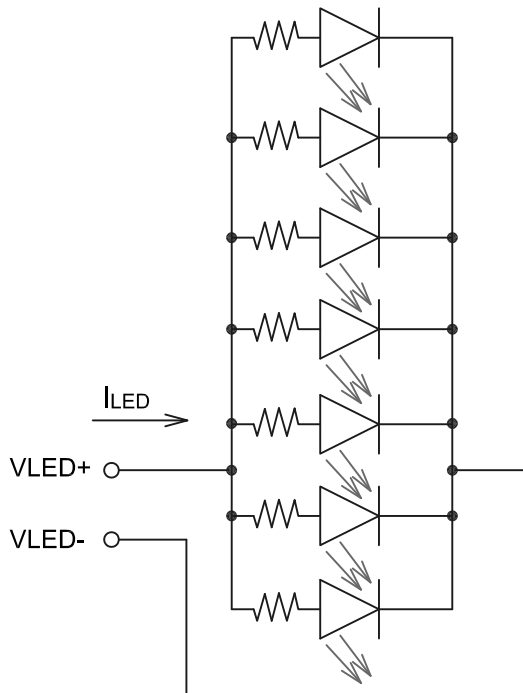
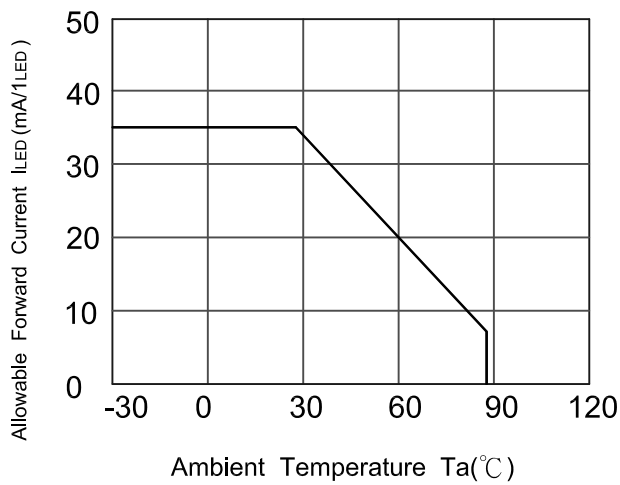

# 6. OPTICAL CHARACTERISTICS

## 6.1 OPTICAL CHARACTERISTICS

Ta=25°C (Backlight on)

ITEM	SYMBOL	CONDITION	MIN.	TYP.	MAX.	UNIT	REMARKS
Viewing Area	$\phi_{RR}-\phi_F$	$K \geq 2.0$	-	80	-	deg	Note 1, 2
	$\phi_{RT}-\phi_L$			90			
Contrast Ratio	K	$\phi=0^\circ, \theta=0^\circ$	-	5	-	-	Note 3, 5, 6
Response Time (Rise)	tr	$\phi=0^\circ, \theta=0^\circ$	-	280	-	ms	Note 4
Response Time (Fall)	tf	$\phi=0^\circ, \theta=0^\circ$	-	280	-	ms	Note 4

(Measurement condition : KOE standard)

Note 2~7 : See next page.

Note 1 : Definition of Viewing Angle

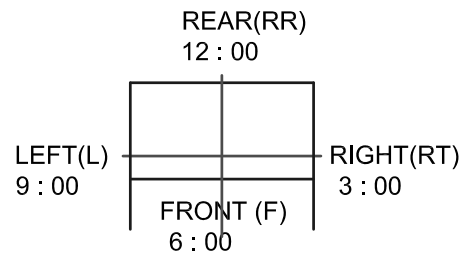
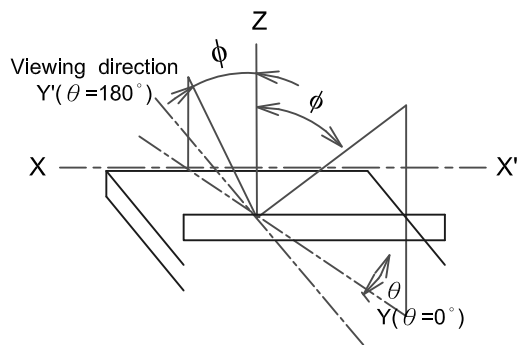

LEFT-RIGHT Direction

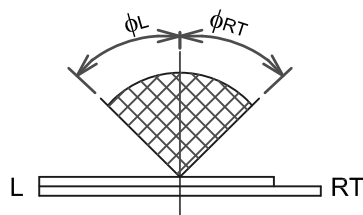

REAR-FRONT Direction

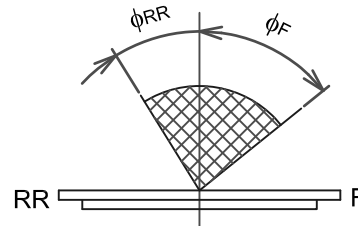

\* The viewing direction of this product is 6 O'clock.

So  $\phi_F > \phi_{RR}$

Note 2 : Definition of viewing angle

$\phi_{RR}$  and  $\phi_F$  ,  $\phi_{RT}$  and  $\phi_L$

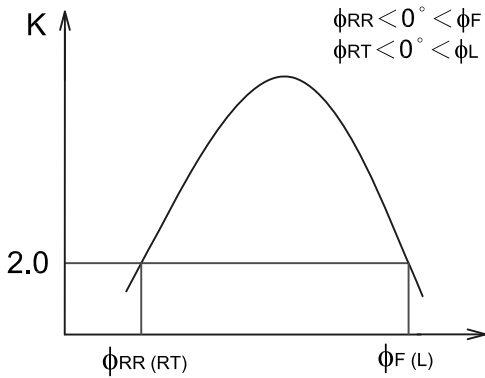

Viewing Angle

Contrast ratio K vs viewing angle  $\phi$

Note 3 : Definition of contrast "K"

$$K = \frac{\text{Brightness on selected dot (B1)}}{\text{Brightness on non-selected dot (B2)}}$$

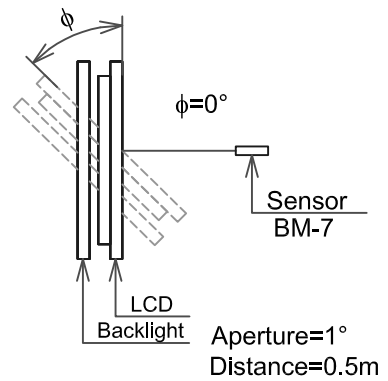
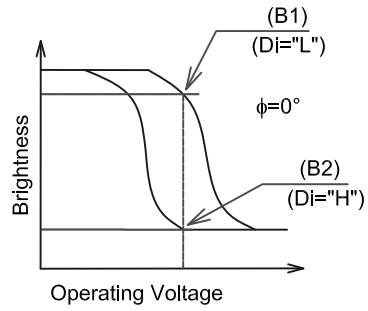

Note 4 : Definition of optical response time

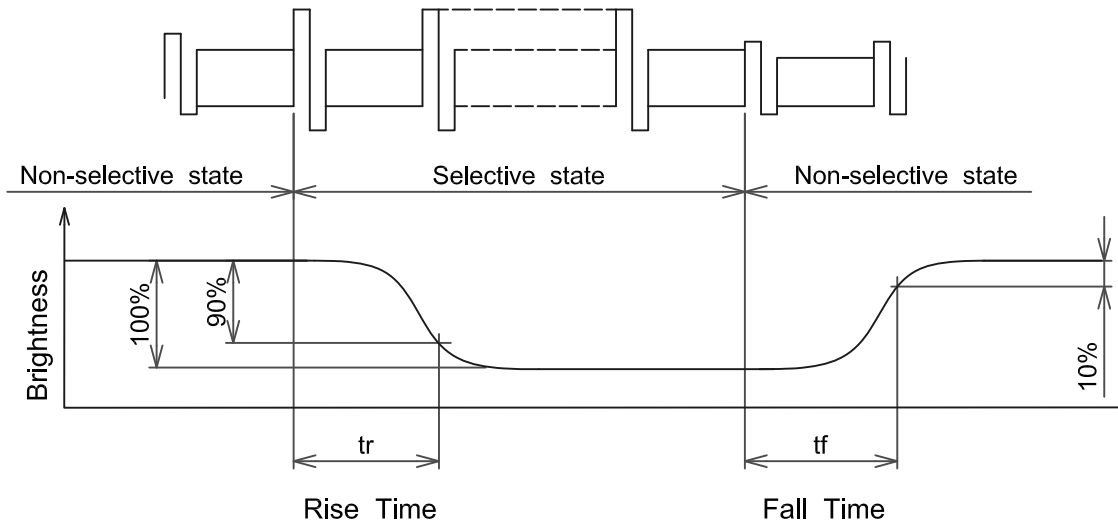

## 6.2 OPTICAL CHARACTERISTICS OF BACKLIGHT

(Backlight ON)

ITEM	MIN.	TYP.	MAX.	UNIT	REMARKS
Brightness	—	60	—	cd/m <sup>2</sup>	ILED=80mA
Brightness uniformity	—	—	±40	%	Undermentioned Note1

Ta=25°C VDD-VEE=23.0V

Display data should be all "ON".

Note 1 : Measurement of the following 9 places on the display.

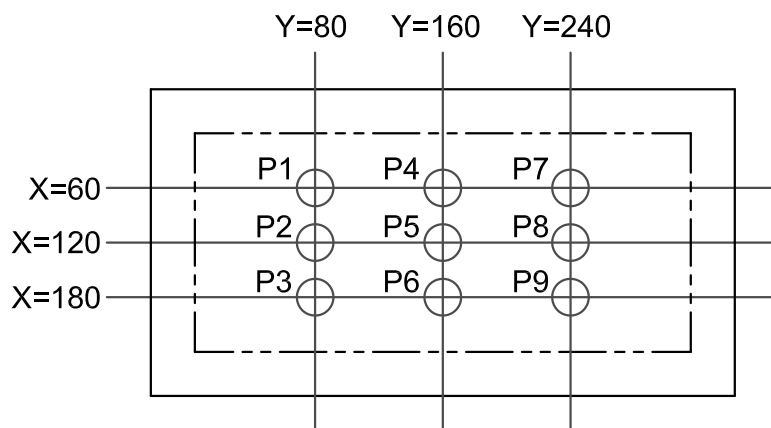

Definition of the brightness tolerance.

$$\left( \frac{\text{max. Brightness or min. Brightness} - \text{Average Brightness}}{\text{Average Brightness}} \right) \times 100\%$$

# 7. BLOCK DIAGRAM

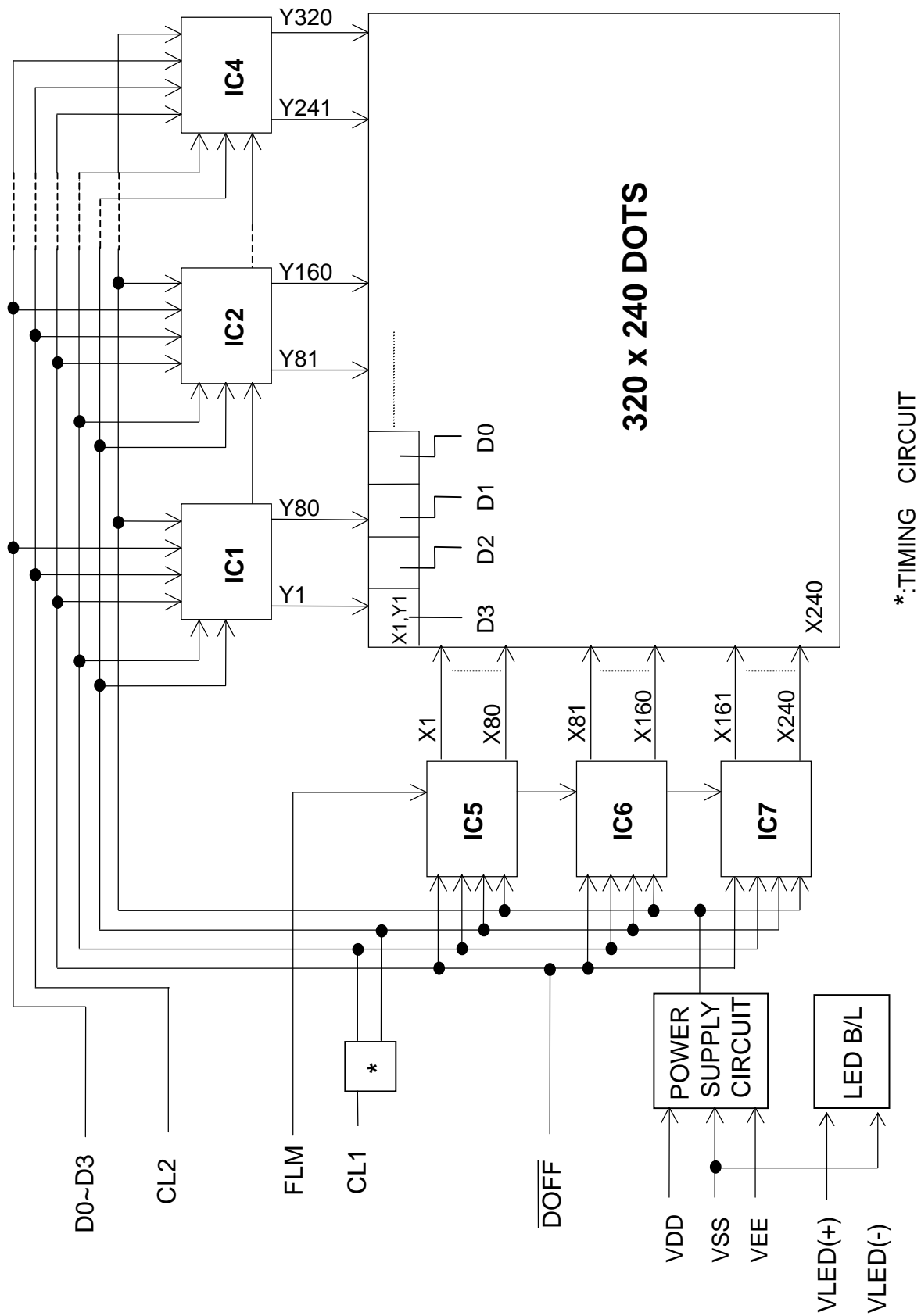

\*:TIMING CIRCUIT

# 8. INTERFACE TIMING CHART

## 8.1 INTERFACE TIMING CHART

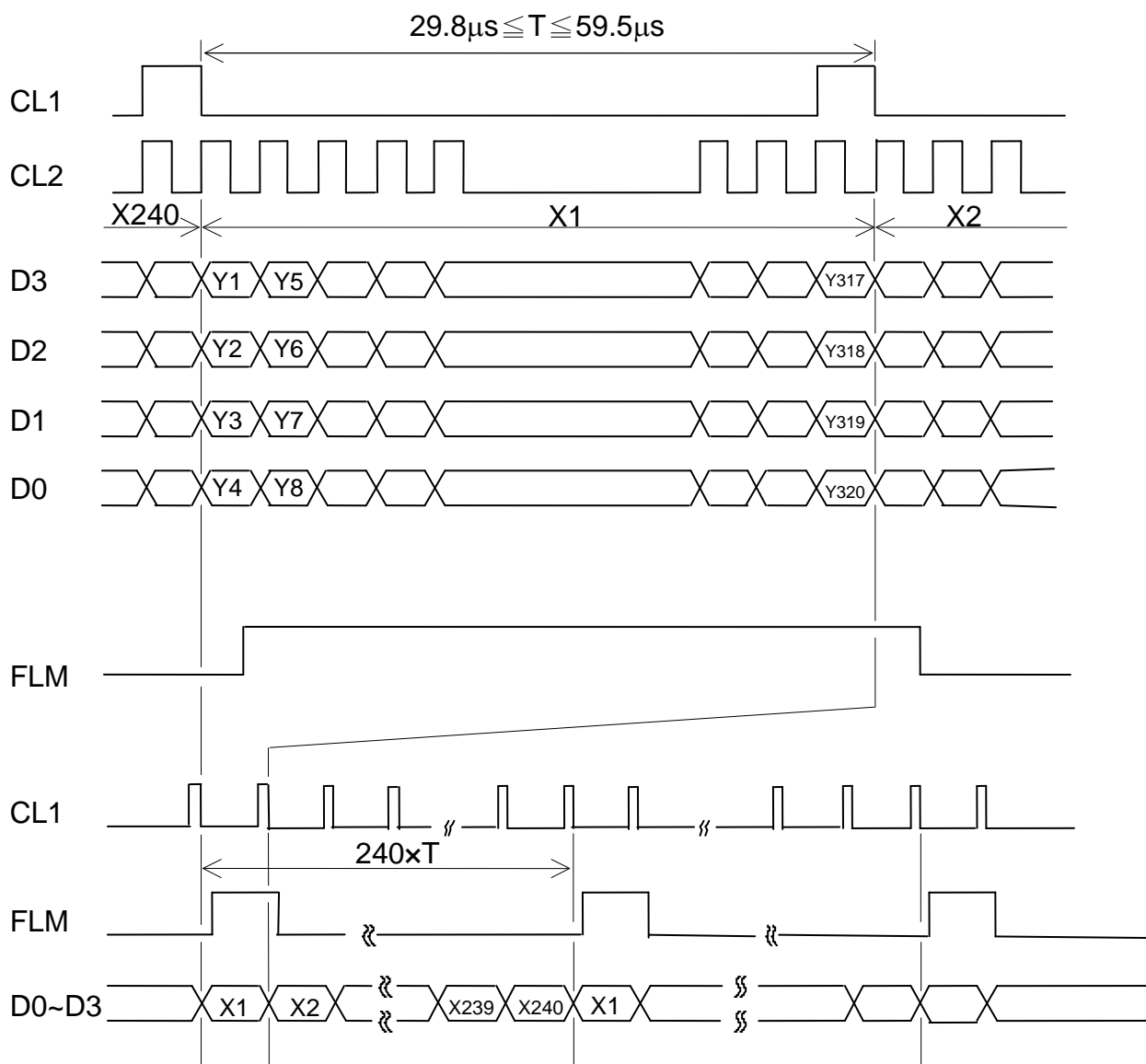

## 8.2 TIMING CHARACTERISTICS

$0^{\circ}\text{C} \leq T_a \leq 40^{\circ}\text{C}, V_{DD}=5\text{V} \pm 5\%$

ITEM	SYMBOL	MIN.	TYP.	MAX.	UNIT
"CL2" Clock Frequency	fCL2	-	-	40	MHz
"CL2" Clock Pulse Width	tW	63	-	-	ns
Clock Rise, Fall Time	tr,tf	-	-	20	ns
Data Set Up Time	tDSU	50	-	-	ns
Data Hold Time	tDHD	50	-	-	ns
CL1 Set Up Time	tLSU	80	-	-	ns
CL1 Hold Time	tLC	80	-	-	ns
"FLM" Set Up Time	tSETUP	100	-	-	ns
"FLM" Hold Time	tHOLD	100	-	-	ns
"CL1" Pulse Width	tWC	125	-	-	ns

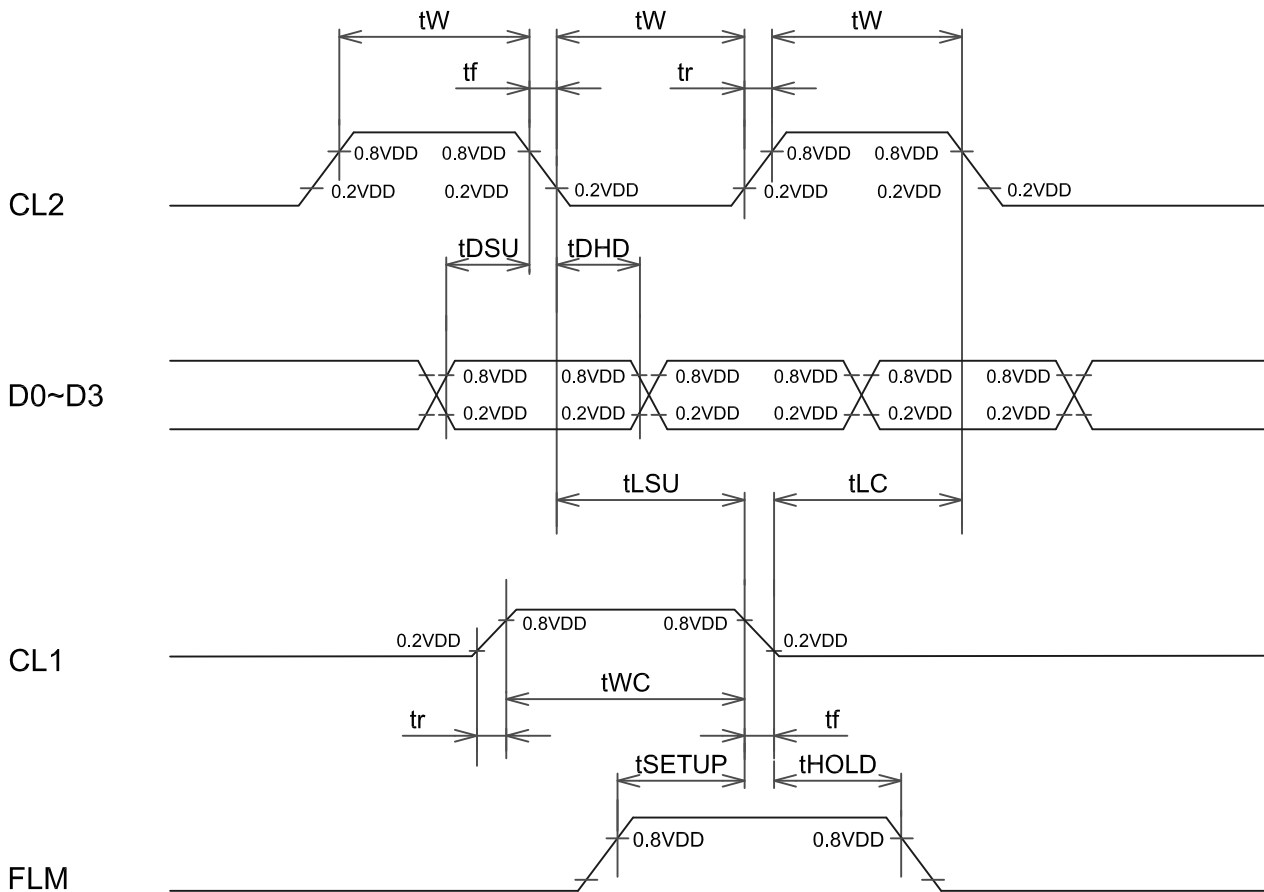

### 8.3 POWER ON/OFF TIMING SEQUENCE

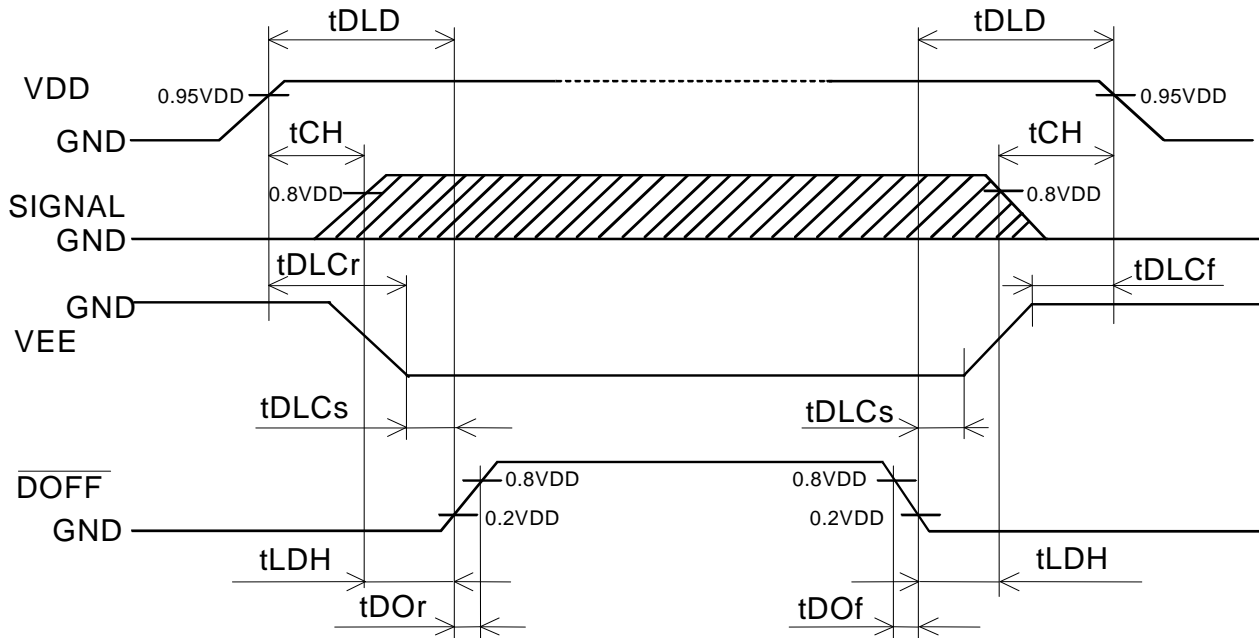

SYMBOL	MIN.	MAX.	UNIT	COMMENT
$t_{DLD}$	200	-	ms	Note1
$t_{CH}$	0	-	ms	
$t_{LDH}$	0	-	ms	
$t_{DOr}$	-	100	ns	Note2
$t_{DOF}$	-	100	ns	
$t_{DLCr}$	20	-	ms	
$t_{DLCf}$	0	-	ms	
$t_{DLCs}$	20	-	ms	

Note 1: Please keep the specified sequence because wrong sequence may cause permanent damage to the LCD panel.

Note 2: KOE recommends you to use  $\overline{DOFF}$  function. display quality may deteriorate if you don't use  $\overline{DOFF}$  function.

### 8.4 POWER SUPPLY FOR LCM

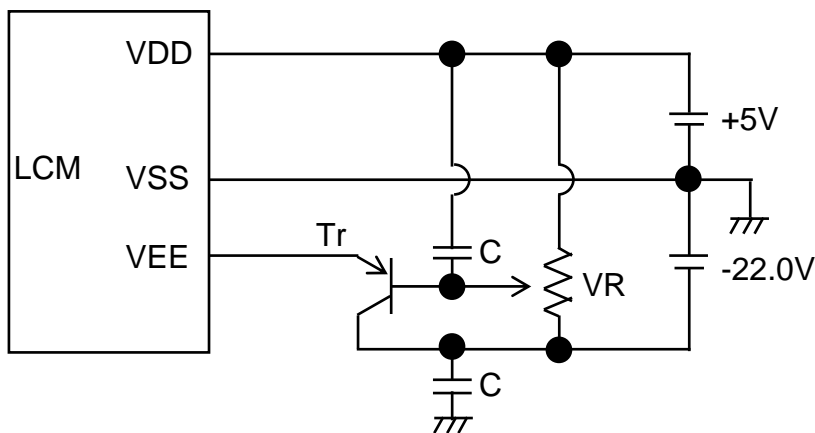

Note 1: C : 3.3  $\mu$  F (aluminum electrolytic capacitor)

VR : 10~20k $\Omega$

Tr : 2SA673APKC (hfe=100 , IC=500mA) or equivalent Tr.

## 8.5 DISPLAY PATTERN

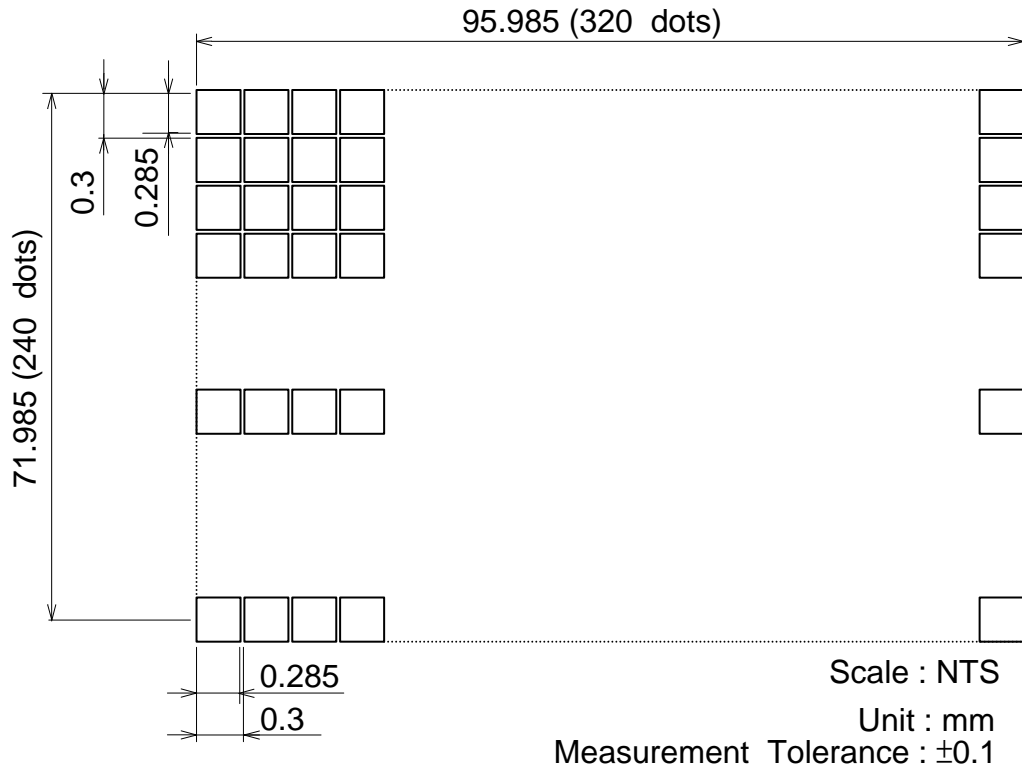

## 8.6 INTERNAL PIN CONNECTION

CN1 : TOKUTSU TERMINAL/BL-113-12RU (Suitable FPC : pitch 1.0mm 12 pins , 0.3t)

INTERFACE	PIN No.	SIGNAL	LEVEL	FUNCTION	
LCM	I/F	1	FLM	H	First Line Marker
		2	CL1	H→L	Data Latch
		3	CL2	H→L	Data Shift
		4	VDD	-	Power Supply for Logic
		5	VSS	-	GND and Power Supply for LED(-)
		6	VEE	-	Power Supply for LC
		7	D0	H/L	Display Data
		8	D1		
		9	D2		
		10	D3		
		11	DOFF	H/L	H:ON / L:OFF
		12	VLED(+)	-	Power Supply for LED(+)

# 9. DIMENSIONAL OUTLINE

## 9.1 DIMENSIONAL OUTLINE

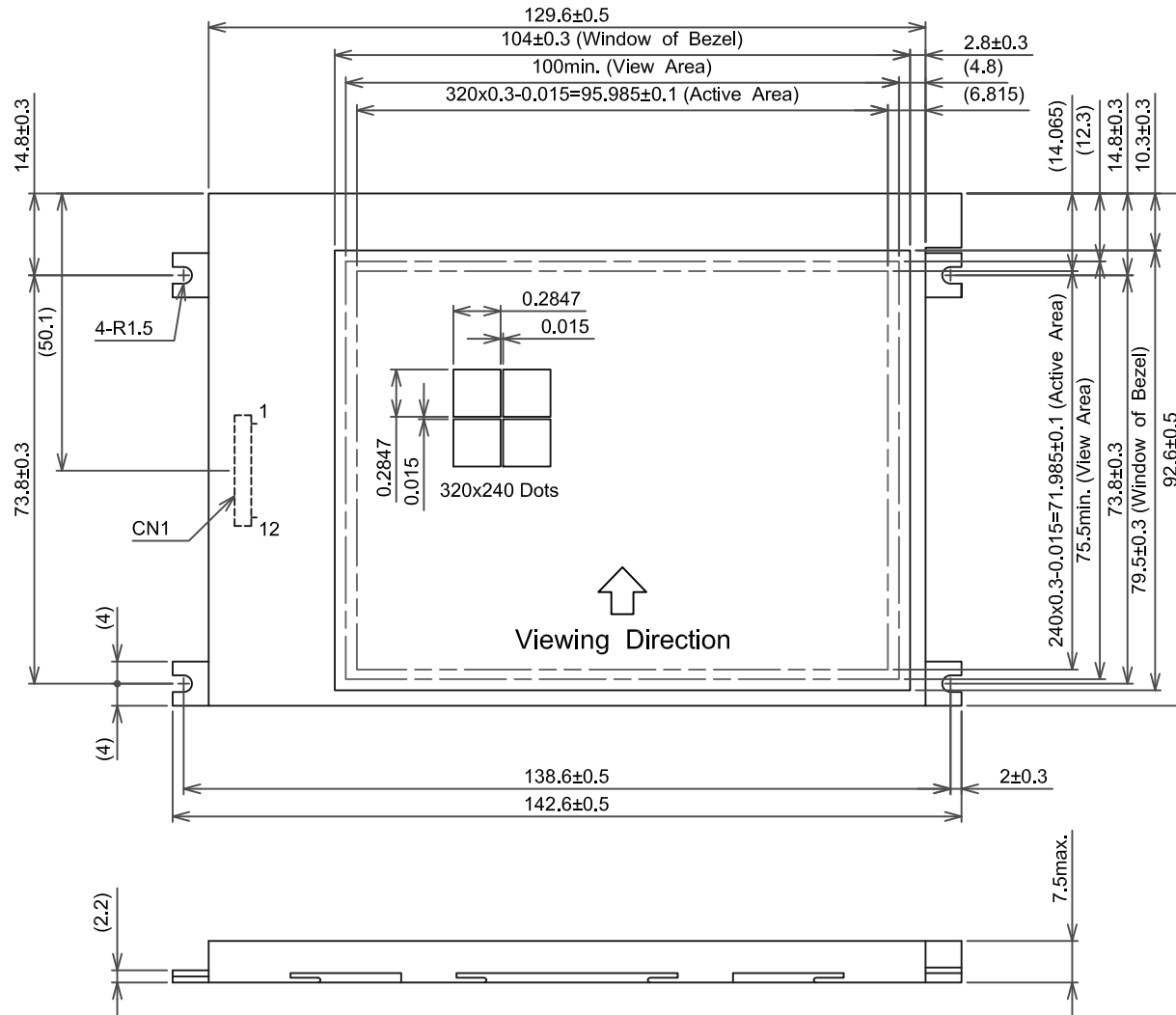

Note 1 : CN1 : MOLEX/52103-1217.

Scale : NTS  
Unit : mm

## 10. APPEARANCE STANDARD

### 10.1 APPEARANCE INSPECTION CONDITION

Visual inspection should be done under the following condition.

- (1) In the dark room.
- (2) With LED panel lighted with prescribed inverter circuit.
- (3) With eyes 25cm distance from LCM.
- (4) Viewing angle within 45 degrees from the vertical line to the center of LCD.

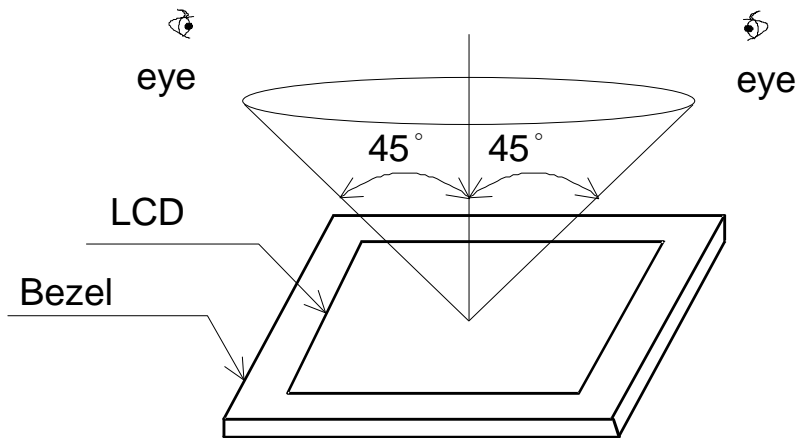

### 10.2 DEFINITION OF EACH ZONE

A zone : Within the active area line specified at page 9-1/1 of this document.

B zone : Area between the window of bezel line and the active area line specified at page 9-1/1 of this document.

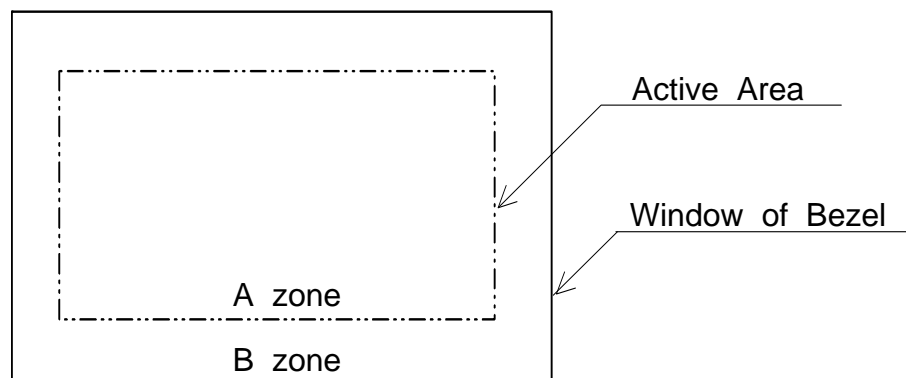

### 10.3 APPEARANCE SPECIFICATION

\*) If the problem occurs about this item, the responsible person of both party (customer and KOE) will discuss more detail.

No.	ITEM	CRITERIA		A	B	
L C D	Scratches	Serious one is not allowed		*	-	
	Dent	Serious one is not allowed		*	-	
	Wrinkles in Polarizer	Serious one is not allowed		*	-	
	Bubbles	Average Diameter D(mm)		Maximum Number Acceptable		
		$D \leq 0.2$		Ignore		
		$0.2 < D \leq 0.3$		12		
		$0.3 < D \leq 0.5$		3		
		$0.5 < D$		None		
	Stains, Foreign Materials Dark Spot	Filamentous			○	-
		Length L(mm)	Width W(mm)	Maximum Number Acceptable		
		$L \leq 2.0$	$W \leq 0.03$	Ignore		
		$L \leq 3.0$	$0.03 < W \leq 0.05$	6		
		-	$0.05 < W$	None		
		Round				
		Average Diameter D(mm)	Maximum Number Acceptable	Space		
		$D < 0.2$	Ignore	-		
		$0.2 \leq D < 0.33$	8	10mm		
		$0.33 \leq D$	None	-		
	The Whole Number		Filamentous + Round = 10			
	Those Wiped Out Easily Are Acceptable				○	○
Pinhole	Average Diameter D(mm)		Maximum Number Acceptable			
	$D \leq 0.15$		Ignore			
	$0.15 < D \leq 0.3$		10			
	$D \leq 0.03$		Ignore			

No.	ITEM	CRITERIA			A	B	
L C D	Contrast Irregularity (Spot)	Average Diameter D(mm)	Maximum Number Acceptable	Minimum Space	○	-	
		$D \leq 0.25$	Ignore	-			
		$0.25 < D \leq 0.35$	$\leq 10$	20mm			
		$0.35 < D \leq 0.5$	$\leq 4$	20mm			
		$0.5 < D$	None	-			
	Contrast Irregularity (Filamentous)	Width D(mm)	Length L(mm)	Maximum Number Acceptable	Minimum Space	○	-
		$W \leq 0.25$	$L \leq 1.2$	$\leq 2$	20mm		
		$W \leq 0.2$	$L \leq 1.5$	$\leq 3$	20mm		
		$W \leq 0.15$	$L \leq 2.0$	$\leq 3$	20mm		
		$W \leq 0.1$	$L \leq 3.0$	$\leq 4$	20mm		
The Whole Number			$\leq 6$				

Note 1: Definition of average diameter D

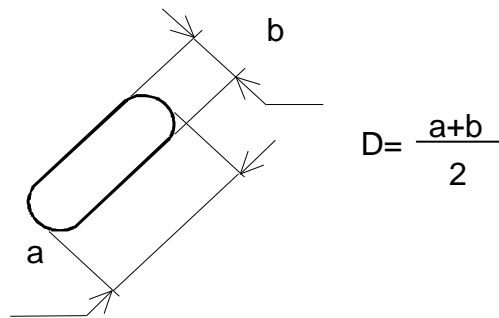

Note 2: Definition of length L and width W

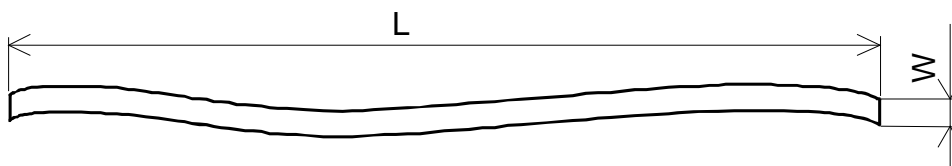

Note 3: Definition of pinhole

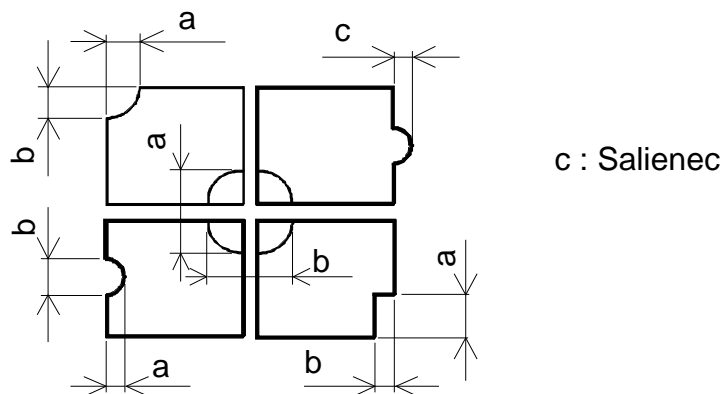

## 11. PRECAUTION IN DESIGN

### 11.1 MOUNTING METHOD

Since the module is so constructed as to be fixed by utilizing fitting holes in the printed circuit board as shown below, it is necessary to take consideration the following items on attachment to a frame.

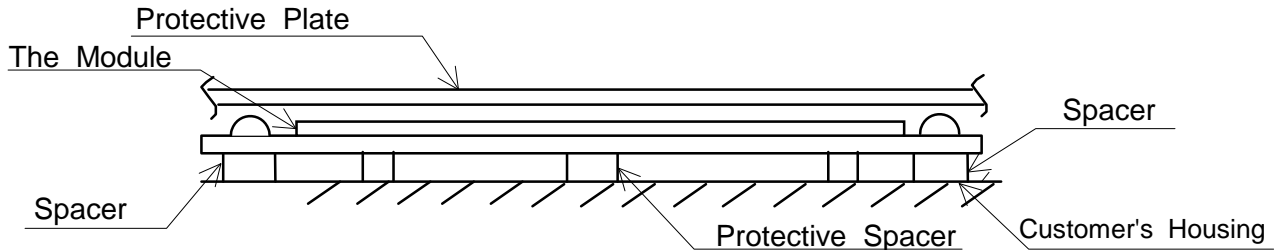

Example Of Mounting

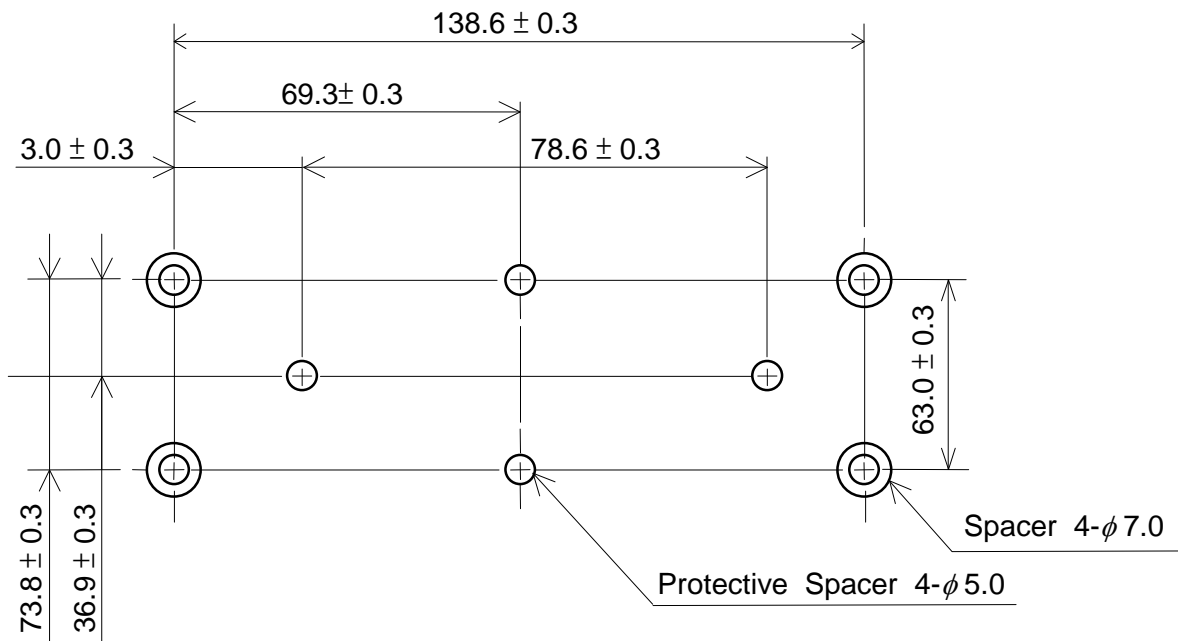

Location Of Spacers

- (1) Use of protective plate, made of an acrylic plate, etc. In order to protect a polarizer and LC cell.
- (2) To prevent the module cover from being pressed, the spacers between the module and the fitting plates should be longer than 0.5mm.
- (3) We recommend you to use protective spacer as figure for protecting LCD module from any kind of shock to your set.

### 11.2 LC DRIVING VOLTAGE(V<sub>EE</sub>) AND VIEWING ANGLE RANGE

Setting V<sub>EE</sub> out of the recommended condition will be a cause for a change of viewing angle range.

### 11.3 CAUTION AGAINST STATIC CHARGE

As this module is provided with C-MOS LSIs, The care to take such a precaution as to grounding the operator's body is required when handling it.

### 11.4 POWER ON SEQUENCE

Input signals should not be applied to LCD module before power supply voltage is applied and reaches to specified voltage ( $5V \pm 5\%$ ).

If above sequence is not kept, C-MOS LSIs of LCD modules may be damaged due to latch up problem.

### 11.5 PACKING

- (1) No. Leaving products is preferable in the place of high humidity for a long period of time. For their storage in the place where temperature is  $35^{\circ}\text{C}$  or higher, special care to prevent them from high humidity is required. A combination of high temperature and high humidity may cause them polarization degradation as well as bubble generation and polarizer peel-off. Please keep the temperature and humidity within the specified range for use and storage.
- (2) Since upper/bottom polarizers tend to be easily damaged , They should be handled full with care so as not get them touched , pushed or rubbed.
- (3) As the adhesives used for adhering upper/bottom polarizers are made of organic substances which will be deteriorated by a chemical reaction with such chemicals as acetone , toluene, ethanol and isopropyl alcohol. The following solvents are recommended for use :  
normal hexane  
Please contact us when it is necessary for you to use chemicals.
- (4) Lightly wipe to clean the dirty surface with absorbent cotton waste or other soft material like chamois, soaked in the chemicals recommended without scrubbing it hardly. To prevent the display surface from damage and keep the appearance in good state, it is sufficient, in general, to wipe it with absorbent cotton.
- (5) Immediately wipe off saliva or water drop attached on the display area because its long period adherence may cause deformation or faded color on the spot.
- (6) Foggy dew deposited on the surface and contact terminals due to coldness will be caused for polarizer damage, stain and dirt on product. When necessary to take out the products from some place at low temperature for test, etc. It is required for them to be warmed up in a container once at the temperature higher than that of room.

- (7) Touching the display area and contact terminals with bare hands and contaminating them are prohibited, because the stain on the display area and poor insulation between terminals are often caused by being touched by bare hands.  
(there are some cosmetics detrimental to polarizers.)
- (8) In general the quality of glass is fragile so that it tends to be cracked or chipped in handling, specially on its periphery. Because be careful not to give it sharp shock caused by dropping down, etc.

#### 11.6 CAUTION FOR OPERATION

- (1) It is an indispensable condition to drive LCDs within the specified voltage limit since the higher voltage than the limit causes the shorter LCD life. An electrochemical reaction due to direct current causes LCDs undesirable deterioration, so that the use of direct current driver should be avoided.
- (2) Response time will be extremely delayed at lower temperature than the operating temperature range and on the other hand at higher temperature LCDs show dark bull color in them. However those phenomena do not mean malfunction or out of order with LCDs which will come back in the specified operating temperature range.
- (3) If the display area is pushed hard during operation, some font will be abnormally display but it resumes normal condition after turning off once.
- (4) A slight dew depositing on terminals is a cause for electrochemical reaction resulting in terminal open circuit. Usage under the relative condition of 40°C 50%RH or less is required.

#### 11.7 STORAGE

In case of storing for a long period of time (for instance, for years) for the purpose of replacement use, the following ways are recommended.

- (1) Storage in a polyethylene bag with the opening sealed so as not to enter fresh air outside in it, and with no desiccant.
- (2) Placing in a dark place where neither exposure to direct sunlight nor light is, keeping temperature in the range from 0°C to 35°C.
- (3) Storing with no touch on polarizer surface by anything else. (It is recommended to store them as they have been contained in the inner container at the time of delivery from us.)

#### 11.8 SAFETY

- (1) It is recommendable to crash damage or unnecessary LCDs into pieces and wash off liquid crystal by either of solvents such as acetone and ethanol, which should be burned up later.
- (2) When any liquid leaked out of a damage glass cell comes in contact with your hands, please wash it off well with soap and water.

## 12. DESIGNATION OF LOT MARK

### 12.1 LOT MARK

Lot mark is consisted of 4 digits for production lot and 6 digits for production control.

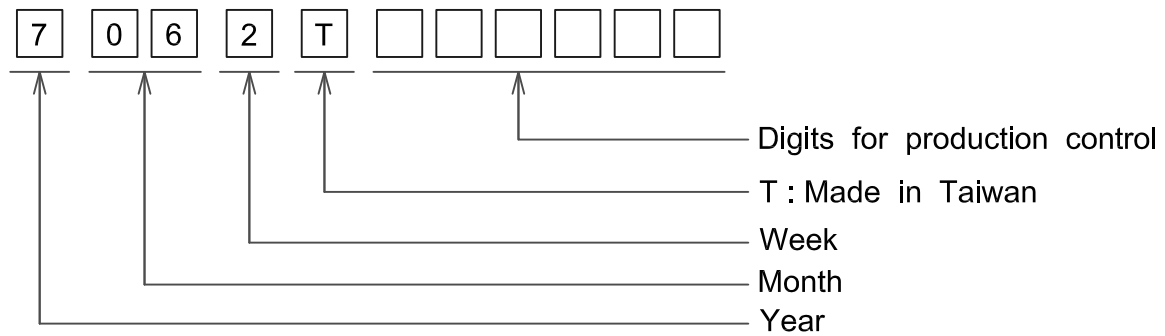

YEAR	FIGURE IN LOT MARK
2007	7
2008	8
2009	9
2010	0
2011	1

MONTH	FIGURE IN LOT MARK	MONTH	FIGURE IN LOT MARK
Jan.	01	Jul.	07
Feb.	02	Aug.	08
Mar.	03	Sep.	09
Apr.	04	Oct.	10
May	05	Nov.	11
Jun.	06	Dec.	12

WEEK (DAY IN CALENDAR)	FIGURE IN LOT MARK
1~7	1
8~14	2
15~21	3
22~28	4
29~31	5

### 12.2 REVISION

REV No.	ITEM	Note
-	-	-
A	Operating Life (40,000h)	-
B	M's IC change	PCN0762
C	CN1 Connector change	PCN0802

### 12.3 Location of lot mark : On the back side of LCM

### 13. PRECAUTION FOR USE

13.1 A limit sample should be provided by the both parties on an occasion when the both parties agreed its necessity. Judgement by a limit sample shall take effect after the limit sample has been established and confirmed by the both parties.

13.2 On the following occasions, the handling of the problem should be decided through discussion and agreement between responsible persons of the both parties.

- (1) When a question is arisen in the specifications.
- (2) When a new problem is arisen which is not specified in this specifications.
- (3) When an inspection specifications change or operating condition change in customer is reported to KOE, and some problem is arisen in this specification due to the change.
- (4) When a new problem is arisen at the customer's operating set for sample evaluation in the customer site.

The precaution that should be observed when handling LCM have been explained above. If any points are unclear or if you have any request , please contact KOE.