

KOE

JDI Group

Kaohsiung Opto-Electronics Inc.

FOR MESSRS : _____

DATE : Aug. 29th,2017

CUSTOMER'S ACCEPTANCE SPECIFICATIONS

TX17D01VM5BAA



Contents

No.	ITEM	SHEET No.	PAGE
1	COVER	7B64PS 2701-TX17D01VM5BAA-2	1-1/1
2	RECORD OF REVISION	7B64PS 2702-TX17D01VM5BAA-2	2-1/1
3	GENERAL DATA	7B64PS 2703-TX17D01VM5BAA-2	3-1/1
4	ABSOLUTE MAXIMUM RATINGS	7B64PS 2704-TX17D01VM5BAA-2	4-1/1
5	ELECTRICAL CHARACTERISTICS	7B64PS 2705-TX17D01VM5BAA-2	5-1/1
6	OPTICAL CHARACTERISTICS	7B64PS 2706-TX17D01VM5BAA-2	6-1/2~2/2
7	BLOCK DIAGRAM	7B64PS 2707-TX17D01VM5BAA-2	7-1/1
8	RELIABILITY TESTS	7B64PS 2708-TX17D01VM5BAA-2	8-1/1
9	LCD INTERFACE	7B64PS 2709-TX17D01VM5BAA-2	9-1/7~7/7
10	OUTLINE DIMENSIONS	7B64PS 2710-TX17D01VM5BAA-2	10-1/2~2/2
11	APPEARANCE STANDARD	7B64PS 2711-TX17D01VM5BAA-2	11-1/3~3/3
12	PRECAUTIONS	7B64PS 2712-TX17D01VM5BAA-2	12-1/2~2/2
13	DESIGNATION OF LOT MARK	7B64PS 2713-TX17D01VM5BAA-2	13-1/1

ACCEPTED BY: _____

PROPOSED BY: John Chou

2. RECORD OF REVISION

DATE	SHEET No.	SUMMARY									
Aug.29,'17	7B64PS 2701 - TX17D01VM5BAA-2 Page 13-1/1	<p>13. DESIGNATION of LOT MARK</p> <p>Added :</p> <table border="1" data-bbox="676 302 1410 430"> <thead> <tr> <th>REV.No</th> <th>ITEM</th> <th>REMARKS</th> </tr> </thead> <tbody> <tr> <td>A</td> <td>-</td> <td>-</td> </tr> <tr> <td>B</td> <td>LCD source changed</td> <td>PCN 0976</td> </tr> </tbody> </table> <p>Revised :</p> <div style="display: flex; align-items: center; justify-content: center;"> <div style="text-align: center;">  <p data-bbox="636 611 983 694"> TX17D01VM5BAA REV:A 9044T (5E) 005373 KOE MADE IN TAIWAN </p> </div> <div style="margin: 0 10px;">→</div> <div style="text-align: center;">  <p data-bbox="1082 611 1434 694"> TX17D01VM5BAA REV:B 7094T (5F) 123456 KOE MADE IN TAIWAN </p> </div> </div>	REV.No	ITEM	REMARKS	A	-	-	B	LCD source changed	PCN 0976
REV.No	ITEM	REMARKS									
A	-	-									
B	LCD source changed	PCN 0976									

3. GENERAL DATA

3.1 DISPLAY FEATURES

This module is a 6.5" VGA of 4:3 format amorphous silicon TFT. The pixel format is vertical stripe and sub pixels are arranged as R (red), G (green), B (blue) sequentially. This display is RoHS compliant, COG (chip on glass) technology and LED backlight are applied on this display.

Part Name	TX17D01VM5BAA
Module Dimensions	153.0(W) mm x 118.0(H) mm x 9.1 (D) mm typ.
LCD Active Area	132.48(W) mm x 99.36(H) mm
Pixel Pitch	0.207(W) mm x 0.207 (H) mm
Resolution	640 x 3(RGB)(W) x 480(H) dots
Color Pixel Arrangement	R, G, B Vertical stripe
LCD Type	Transmissive Color TFT; Normally White
Display Type	Active Matrix
Number of Colors	262k Colors
Backlight	12 LEDs (3 series x 4)
Weight	190g
Interface	C-MOS; 18-bit RGB; 31 pins
Power Supply Voltage	3.3V for LCD; 12V for Backlight
Power Consumption	0.48 W for LCD; 4.08 W for Backlight
Viewing Direction	Super Wide Version

4. ABSOLUTE MAXIMUM RATINGS

Item	Symbol	Min.	Max.	Unit	Remarks
Supply Voltage	V_{DD}	-0.3	5	V	-
Input Voltage of Logic	V_I	-0.3	$V_{DD}+0.3$	V	Note 1
Operating Temperature	T_{op}	-20	70	°C	Note 2
Storage Temperature	T_{st}	-30	80	°C	Note 2

Note 1: The rating is defined for the signal voltages of the interface such as CLK, DE, Hsync, Vsync and RGB data bus.

Note 2: The maximum rating is defined as above based on the chamber temperature, which might be different from ambient temperature after assembling the panel into the application. Moreover, some temperature-related phenomenon as below needed to be noticed:

- Background color, contrast and response time would be different in temperatures other than 25°C.
- Operating under high temperature will shorten LED lifetime.

5. ELECTRICAL CHARACTERISTICS

5.1 LCD CHARACTERISTICS

$T_a = 25\text{ }^\circ\text{C}$, $V_{SS} = 0\text{V}$

Item	Symbol	Condition	Min.	Typ.	Max.	Unit	Remarks
Power Supply Voltage	V_{DD}	-	3.0	3.3	3.6	V	-
Input Voltage of Logic	V_I	"H" level	$0.7V_{DD}$	-	V_{DD}	V	Note 1
		"L" level	V_{SS}	-	$0.3V_{DD}$		
Power Supply Current	I_{DD}	$V_{DD}=3.3\text{V}$	-	144	172	mA	Note 2,3
Vsync Frequency	f_v	-	-	60	66	Hz	-
Hsync Frequency	f_H	-	27.86	31.5	37.62	KHz	-
CLK Frequency	f_{CLK}	-	22.29	25.2	37.62	MHz	-

Note 1: The rating is defined for the signal voltages of the interface such as DE, CLK and RGB data bus.

Note 2: An all black check pattern is used when measuring I_{DD} . f_v is set to 60 Hz.

Note 3: 1.0A fuse is applied in the module for I_{DD} . For display activation and protection purpose, power supply is recommended larger than 2.5A to start the display and break fuse once any short circuit occurred.

5.2 BACKLIGHT CHARACTERISTICS

$T_a = 25\text{ }^\circ\text{C}$

Item	Symbol	Condition	Min.	Typ.	Max.	Unit	Remarks
LED Input Voltage	V_{LED}	-	11.7	12	12.3	V	Note1
LED Forward Current (Dim Control)	I_{LED}	0V; 0% duty	320	340	360	mA	Note 2
		3.3VDC; 100% duty	24	30	36		
LED lifetime	-	340 mA	-	70K	-	hrs	Note 3

Note 1: As Fig. 5.1 shown, LED current is constant, 340 mA, controlled by the LED driver when applying 12V V_{LED} .

Note 2: Dimming function can be obtained by applying DC voltage or PWM signal from the display interface CN1. The recommended PWM signal is 1K ~ 10K Hz with 3.3V amplitude.

Note 3: The estimated lifetime is specified as the time to reduce 50% brightness by applying 340 mA at 25°C.

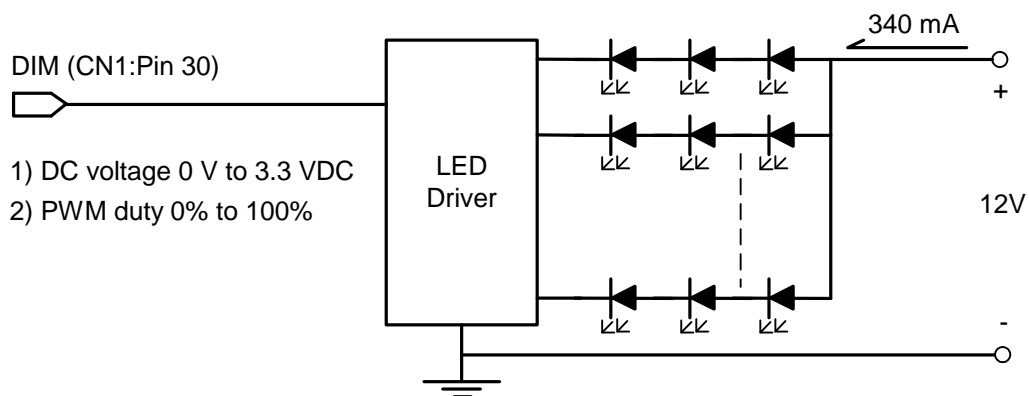

Fig. 5.1

6. OPTICAL CHARACTERISTICS

The optical characteristics are measured based on the conditions as below:

- Supplying the signals and voltages defined in the section of electrical characteristics.
- The backlight unit needs to be turned on for 30 minutes.
- The ambient temperature is 25 °C .
- In the dark room around 500~1000 lx, the equipment has been set for the measurements as shown in Fig 6.1.

$$T_a = 25 \text{ }^\circ\text{C}, f_v = 60 \text{ Hz}, V_{DD} = 3.3\text{V}$$

Item	Symbol	Condition	Min.	Typ.	Max.	Unit	Remarks	
Brightness of White	-	$\phi = 0^\circ, \theta = 0^\circ,$ $I_{LED} = 340 \text{ mA}$	640	800	-	cd/m ²	Note 1	
Brightness Uniformity	-		70	-	-	%	Note 2	
Contrast Ratio	CR		-	350	-	-	Note 3	
Response Time (Rising + Falling)	$T_r + T_f$	$\phi = 0^\circ, \theta = 0^\circ$	-	30	-	ms	Note 4	
NTSC Ratio	-	$\phi = 0^\circ, \theta = 0^\circ$	-	50	-	%	-	
Viewing Angle	θ_x	$\phi = 0^\circ, CR \geq 10$	-	80	-	Degree	Note 5	
	$\theta_{x'}$	$\phi = 180^\circ, CR \geq 10$	-	80	-			
	θ_y	$\phi = 90^\circ, CR \geq 10$	-	80	-			
	$\theta_{y'}$	$\phi = 270^\circ, CR \geq 10$	-	80	-			
Color Chromaticity	Red	X	$\phi = 0^\circ, \theta = 0^\circ$	0.54	0.59	0.64	-	Note 6
		Y		0.29	0.34	0.39		
	Green	X		0.29	0.34	0.39		
		Y		0.53	0.58	0.63		
	Blue	X		0.10	0.15	0.20		
		Y		0.09	0.14	0.19		
	White	X		0.27	0.32	0.37		
		Y		0.30	0.35	0.40		

Note 1: The brightness is measured from the panel center point, P5 in Fig. 6.2, for the typical value.

Note 2: The brightness uniformity is calculated by the equation as below:

$$\text{Brightness uniformity} = \frac{\text{Min. Brightness}}{\text{Max. Brightness}} \times 100\%$$

, which is based on the brightness values of the 9 points measured by BM-5 as shown in Fig. 6.2.

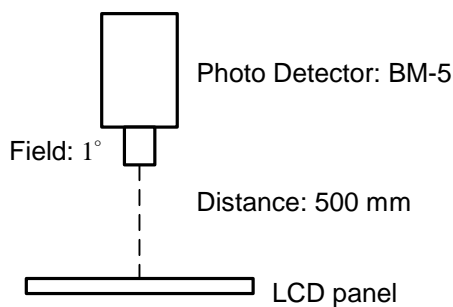

Fig. 6.1

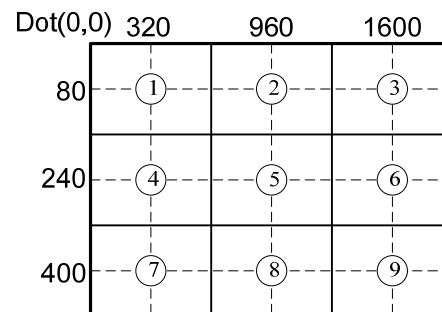

Fig. 6.2

Note 3: The Contrast Ratio is measured from the center point of the panel, P5, and defined as the following equation:

$$CR = \frac{\text{Brightness of White}}{\text{Brightness of Black}}$$

Note 4: The definition of response time is shown in Fig. 6.3. The rising time is the period from 90% brightness to 10% brightness when the data is from white to black. Oppositely, Falling time is the period from 10% brightness rising to 90% brightness.

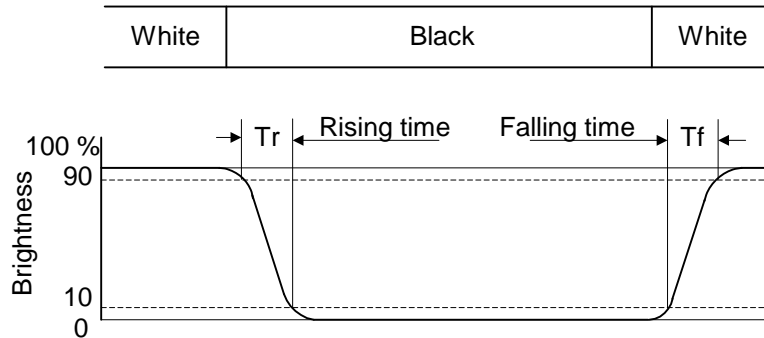

Fig . 6.3

Note 5: The definition of viewing angle is shown in Fig. 6.4. Angle ϕ is used to represent viewing directions, for instance, $\phi = 270^\circ$ means 6 o'clock, and $\phi = 0^\circ$ means 3 o'clock. Moreover, angle θ is used to represent viewing angles from axis Z toward plane XY.

The viewing direction of this display is 12 o'clock, which means that a photograph with gray scale would not be reversed in color and the brightness change would be less from this direction. However, the best contrast peak would be located at 6 o'clock.

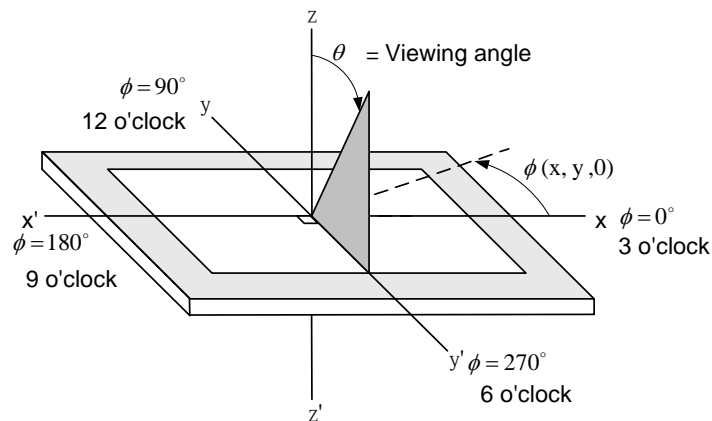
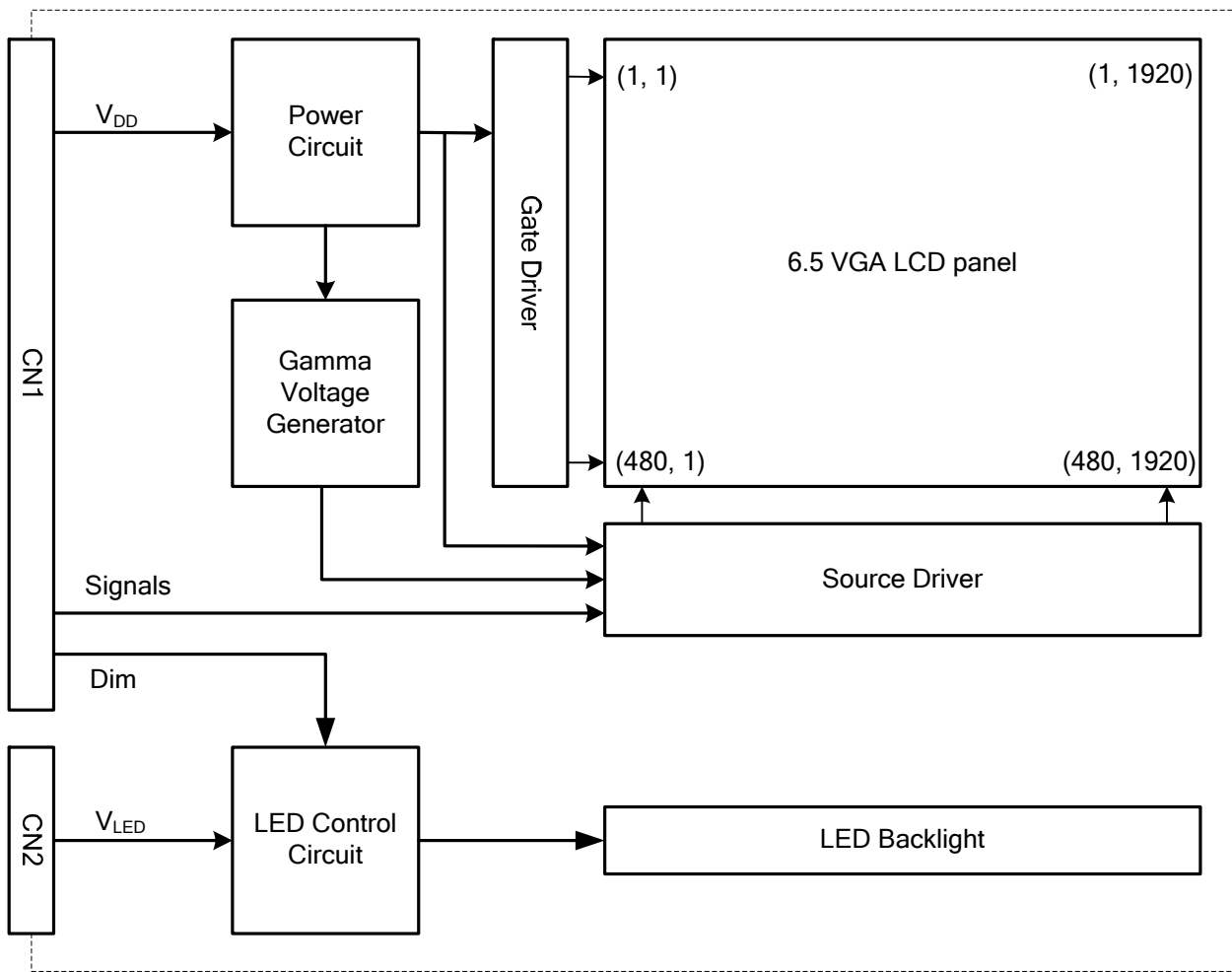

Fig 6.4

Note 6: The color chromaticity is measured from the center point of the panel, P5, as shown in Fig. 6.2.

7. BLOCK DIAGRAM



Note1: Signals are CLK, Hsync, Vsync, DE, SD, and RGB data bus.

8. RELIABILITY TESTS

Test Item	Condition	
High Temperature	1) Operating 2) 70 °C	240 hrs
Low Temperature	1) Operating 2) -20 °C	240 hrs
High Temperature	1) Storage 2) 80 °C	240 hrs
Low Temperature	1) Storage 2) -30 °C	240 hrs
Heat Cycle	1) Operating 2) -20 °C ~70 °C 3) 3hrs~1hr~3hrs	240 hrs
Thermal Shock	1) Non-Operating 2) -35 °C ↔ 85 °C 3) 0.5 hr ↔ 0.5 hr	240 hrs
High Temperature & Humidity	1) Operating 2) 40 °C & 85%RH 3) Without condensation (Note3)	240 hrs
Vibration	1) Non-Operating 2) 20~200 Hz 3) 2G 4) X, Y, and Z directions	1 hr for each direction
Mechanical Shock	1) Non-Operating 2) 10 ms 3) 50G 4) ±X, ± Y and ±Z directions	Once for each direction
ESD	1) Operating 2) Tip: 200 pF, 250 Ω 3) Air discharge for glass: ±8KV 4) Contact discharge for metal frame: ±8KV	1) Glass: 9 points 2) Metal frame: 8 points (Note4)

Note 1: Display functionalities are inspected under the conditions defined in the specification after the reliability tests.

Note 2: The display is not guaranteed for use in corrosive gas environments.

Note 3: Under the condition of high temperature & humidity, if the temperature is higher than 40 °C, the humidity needs to be reduced as Fig. 8.1 shown.

Note 4: All pins of LCD interface (CN1) have been tested by ±100V contact discharge of ESD under non-operating condition.

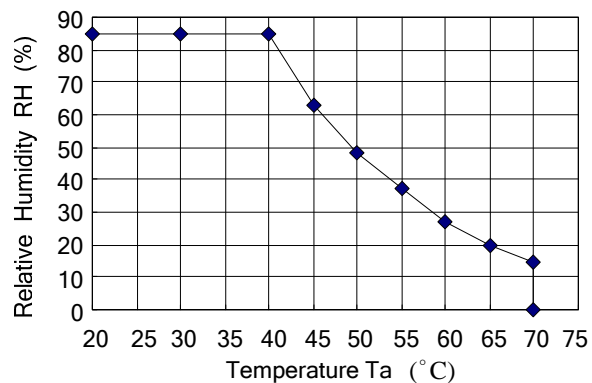

Fig. 8.1

9. LCD INTERFACE

9.1 INTERFACE PIN CONNECTIONS

The display interface connector (CN1) is DF9-31P-1V made by Hirose, and Pin assignment is as below:

Pin No.	Symbol	Signal
1	GND	Ground
2	CLK	Dot Clock
3	HSYNC	Horizontal synchronous signal and mode selection Synchronous Mode: Hsync signal input Data Enable Mode: Open or Low
4	VSYNC	Vertical synchronous signal
5	GND	Ground
6	R0	Red data (LSB)
7	R1	Red data
8	R2	Red data
9	R3	Red data
10	R4	Red data
11	R5	Red data (MSB)
12	GND	Ground
13	G0	Green data (LSB)
14	G1	Green data
15	G2	Green data
16	G3	Green data
17	G4	Green data
18	G5	Green data (MSB)
19	GND	Ground
20	B0	Blue data (LSB)
21	B1	Blue data
22	B2	Blue data
23	B3	Blue data
24	B4	Blue data
25	B5	Blue data (MSB)
26	GND	Ground
27	DE	Data Enable Signal
28	V _{DD}	Power Supply
29	V _{DD}	Power Supply
30	DIM	Normal Brightness: 0V or 0% PWM Duty Brightness Control: 0V to 3.3 VDC or 0% to 100% PWM Duty
31	SD	Normal Scan: Low or open Reverse Scan: High

The backlight connector (CN2) is SM02 (8.0)B-BHS-1-TB (LF)(SN) made by JST, and pin assignment is as below:

Pin No.	Symbol	Signal
1	V _{LED}	12VDC
2	GND	Ground

9.2 TIMING CHART

A. SYNCHRONOUS MODE

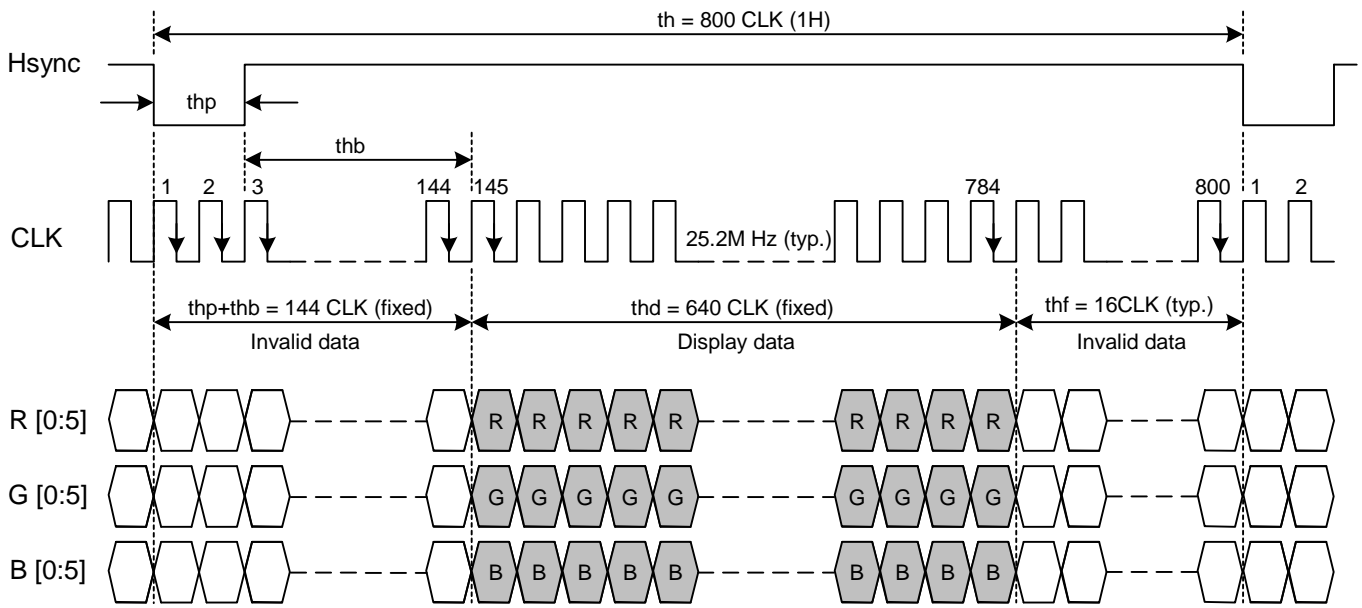

Fig. 9.1 Horizontal Timing of Synchronous Mode

Note 1: CLK's falling edge is the time to latch data and count ($thp + thb$), therefore, data sending and Hsync's falling edge should start when CLK's rise edge.

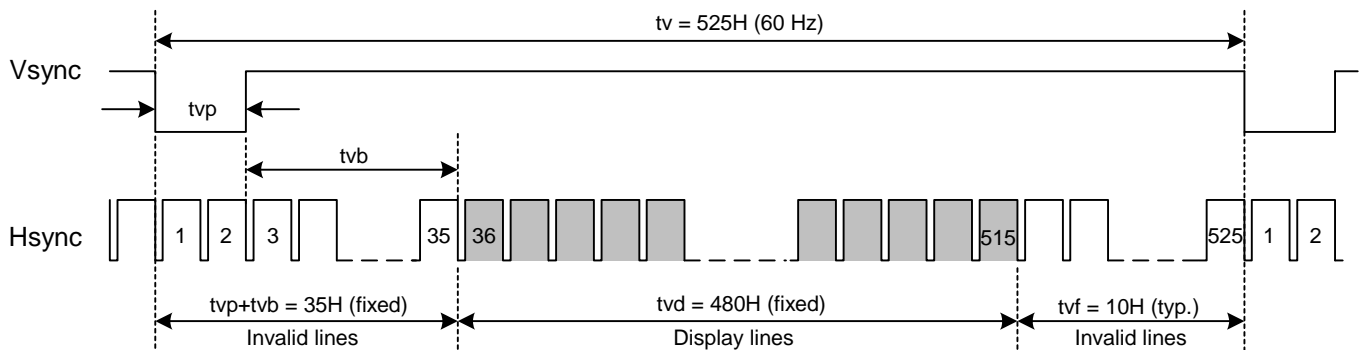

Fig. 9.2 Vertical Timing of Synchronous Mode

Note 2: Vsync's falling edge needs to start with Hsync's falling edge simultaneously to count ($tv_p + tv_b$).

B. DE MODE

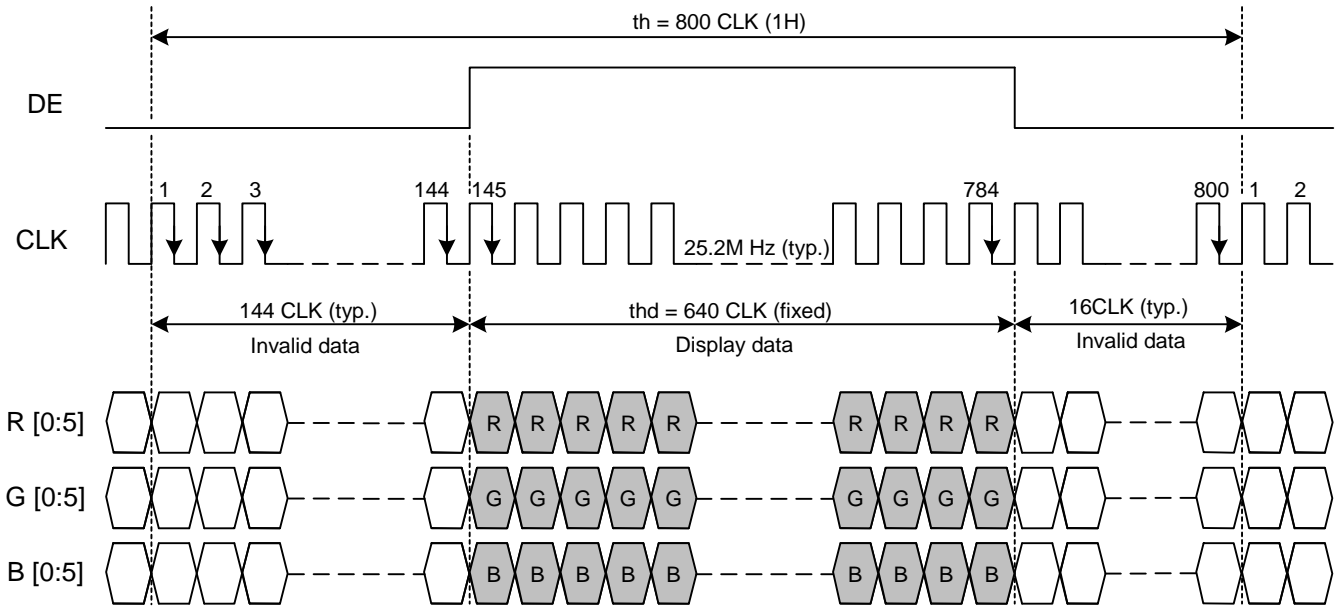

Fig. 9.3 Horizontal Timing of DE Mode

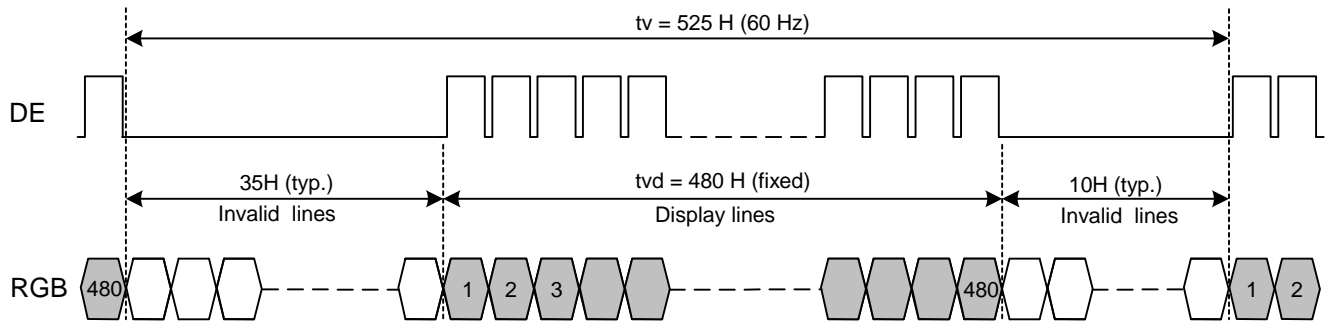

Fig. 9.4 Vertical Timing of DE Mode

C. CLOCK AND DATA INPUT TIMING

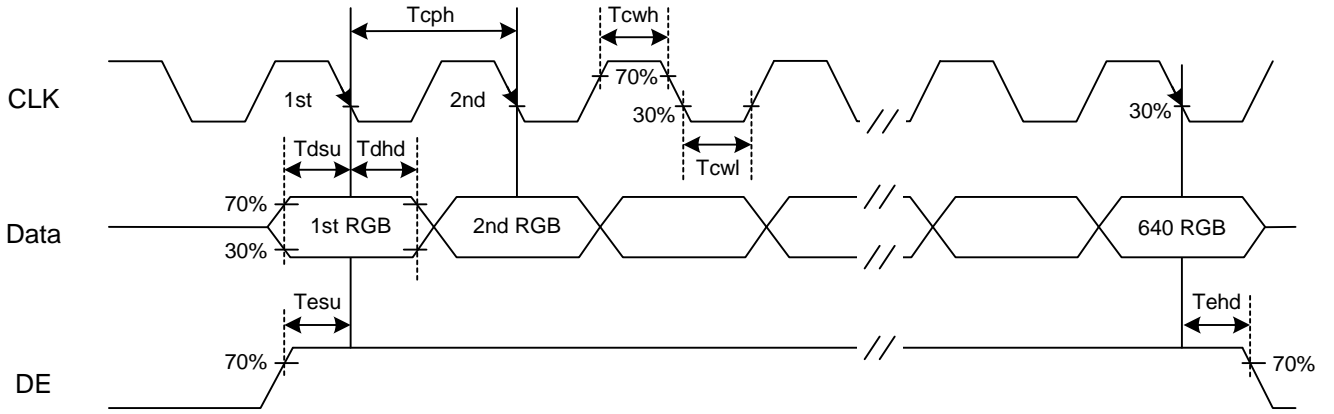

Fig. 9.5 Setup & Hold Time of Data and DE signal.

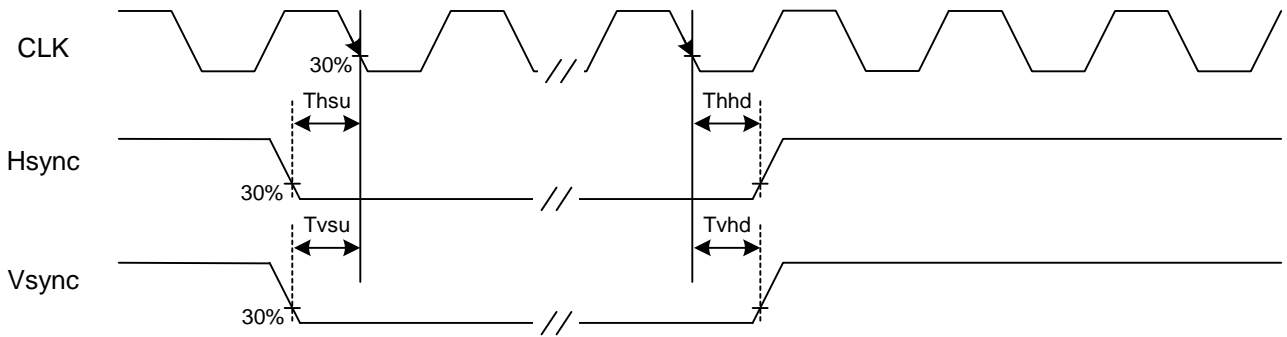

Fig. 9.6 Setup & Hold Time of Hsync and Vsync signal.

9.3 TIME TABLE

The column of timing sets including minimum, typical, and maximum as below are based on the best optical performance, frame frequency (Vsync) = 60 Hz to define. If 60 Hz is not the aim to set, 54~66 Hz for Vsync is recommended to apply for better performance by other parameter combination as the definitions in section 5.1.

A. SYNCHRONOUS MODE

	Item	Symbol	Min.	Typ.	Max.	Unit
Hsync	CLK Frequency	fclk	24.8	25.2	34.2	M Hz
	Display Data	thd	640	640	640	CLK
	Cycle Time	th	800	800	1000	
	Pulse Width	thp	1	2	10	
	Pulse Width and Back Porch	thp + thb	144	144	144	
	Front Porch	thf	16	16	216	
Vsync	Display Line	tvd	480	480	480	H
	Cycle Time	tv	516	525	570	
	Pulse Width	tvp	1	2	10	
	Pulse Width and Back Porch	tvp + tvb	35	35	35	
	Front Porch	tvf	1	10	55	

B. DE MODE

	Item	Symbol	Min.	Typ.	Max.	Unit
Horizontal	CLK Frequency	fclk	24.8	25.2	34.2	M Hz
	Display Data	thd	640	640	640	CLK
	Cycle Time	th	800	800	1000	
Vertical	Display Data	tvd	480	480	480	H
	Cycle Time	tv	516	525	570	

C. CLOCK AND DATA INPUT TIMING

	Item	Symbol	Min.	Typ.	Max.	Unit
CLK	Duty	Tcwh	40	50	60	%
	Cycle Time	Tcph	29.23	39.68	-	ns
Vsync	Setup Time	Tvsu	8	-	-	
	Hold Time	Tvhd	8	-	-	
Hsync	Setup Time	Thsu	8	-	-	
	Hold Time	Thhd	8	-	-	
Data	Setup Time	Tdsu	8	-	-	
	Hold Time	Tdhd	8	-	-	
DE	Setup Time	Tesu	8	-	-	
	Hold Time	Tehd	8	-	-	

9.4 POWER SEQUENCE

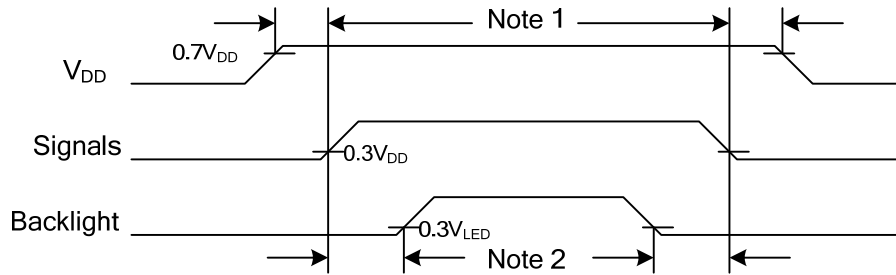

Fig. 9.7 Power Sequence Timing

Note 1: In order to avoid any damages, V_{DD} has to be applied before all other signals. The opposite is true for power Off where V_{DD} has to be remained on until all other signals have been switch off. The recommended time period is 1 second. Hot plugging might cause display damage due to incorrect power sequence, please pay attention on interface connecting before power on.

Note 2: In order to avoid showing uncompleted patterns in transient state. It is recommended that switching the backlight on is delayed for 1 second after the signals have been applied. The opposite is true for power Off where the backlight has to be switched off 1 second before the signals are removed.

9.5 SCAN DIRECTION

Scan direction is available to be switched as below by setting CN1's SD pin.

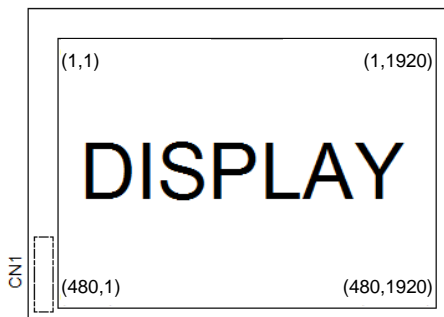

Fig. 9.8 Normal Scan (SD: Low or Open)

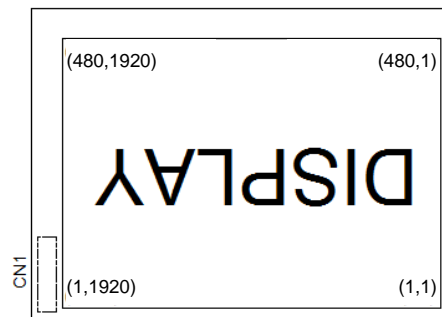

Fig. 9.9 Reverse Scan (SD: High)

9.6 DATA INPUT for DISPLAY COLOR

	COLOR & Gray Scale	Data Signal																	
		R5	R4	R3	R2	R1	R0	G5	G4	G3	G2	G1	G0	B5	B4	B3	B2	B1	B0
Basic Color	Black	0	0	0	0	0	0	0	0	0	0	0	0	0	0	0	0	0	0
	Red (0)	1	1	1	1	1	1	0	0	0	0	0	0	0	0	0	0	0	0
	Green (0)	0	0	0	0	0	0	1	1	1	1	1	1	0	0	0	0	0	0
	Blue (0)	0	0	0	0	0	0	0	0	0	0	0	0	1	1	1	1	1	1
	Cyan	0	0	0	0	0	0	1	1	1	1	1	1	1	1	1	1	1	1
	Magenta	1	1	1	1	1	1	0	0	0	0	0	0	1	1	1	1	1	1
	Yellow	1	1	1	1	1	1	1	1	1	1	1	1	0	0	0	0	0	0
	White	1	1	1	1	1	1	1	1	1	1	1	1	1	1	1	1	1	1
Red	Black	0	0	0	0	0	0	0	0	0	0	0	0	0	0	0	0	0	0
	Red (62)	0	0	0	0	0	1	0	0	0	0	0	0	0	0	0	0	0	0
	Red (61)	0	0	0	0	1	0	0	0	0	0	0	0	0	0	0	0	0	0
	:	:	:	:	:	:	:	:	:	:	:	:	:	:	:	:	:	:	:
	:	:	:	:	:	:	:	:	:	:	:	:	:	:	:	:	:	:	:
	Red (1)	1	1	1	1	1	0	0	0	0	0	0	0	0	0	0	0	0	0
Red (0)	1	1	1	1	1	1	0	0	0	0	0	0	0	0	0	0	0	0	
Green	Black	0	0	0	0	0	0	0	0	0	0	0	0	0	0	0	0	0	0
	Green (62)	0	0	0	0	0	0	0	0	0	0	0	1	0	0	0	0	0	0
	Green (61)	0	0	0	0	0	0	0	0	0	0	1	0	0	0	0	0	0	0
	:	:	:	:	:	:	:	:	:	:	:	:	:	:	:	:	:	:	:
	:	:	:	:	:	:	:	:	:	:	:	:	:	:	:	:	:	:	:
	Green (1)	0	0	0	0	0	0	1	1	1	1	1	0	0	0	0	0	0	0
Green (0)	0	0	0	0	0	0	1	1	1	1	1	1	0	0	0	0	0	0	
Blue	Black	0	0	0	0	0	0	0	0	0	0	0	0	0	0	0	0	0	0
	Blue (62)	0	0	0	0	0	0	0	0	0	0	0	0	0	0	0	0	0	1
	Blue (61)	0	0	0	0	0	0	0	0	0	0	0	0	0	0	0	0	1	0
	:	:	:	:	:	:	:	:	:	:	:	:	:	:	:	:	:	:	:
	:	:	:	:	:	:	:	:	:	:	:	:	:	:	:	:	:	:	:
	Blue (1)	0	0	0	0	0	0	0	0	0	0	0	0	1	1	1	1	1	0
Blue (0)	0	0	0	0	0	0	0	0	0	0	0	0	1	1	1	1	1	1	

10. OUTLINE DIMENSIONS

10.1 FRONT VIEW

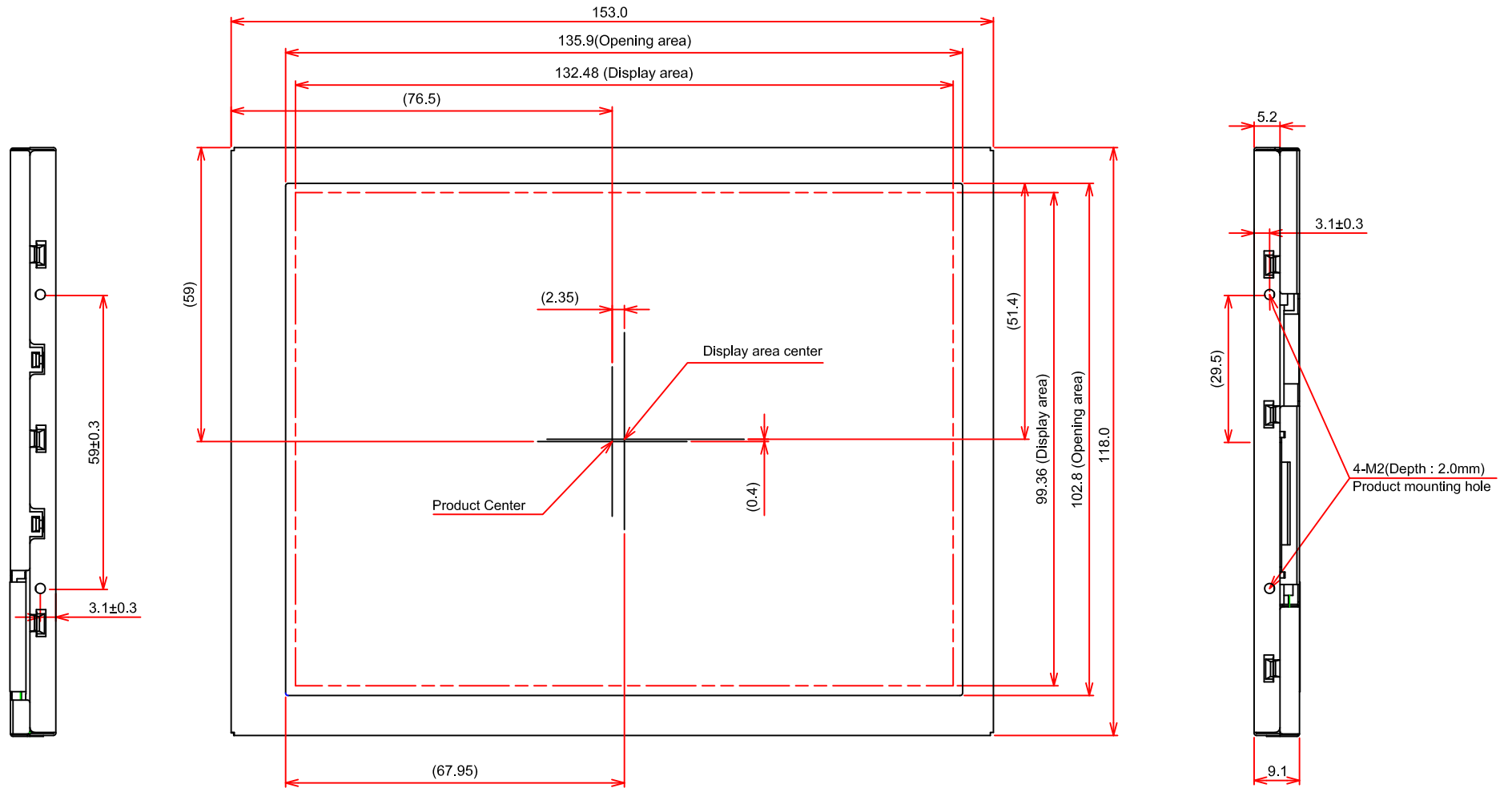

Note 1: General tolerance ±0.5

Scale : NTS
Unit : mm

10.2 REAR VIEW

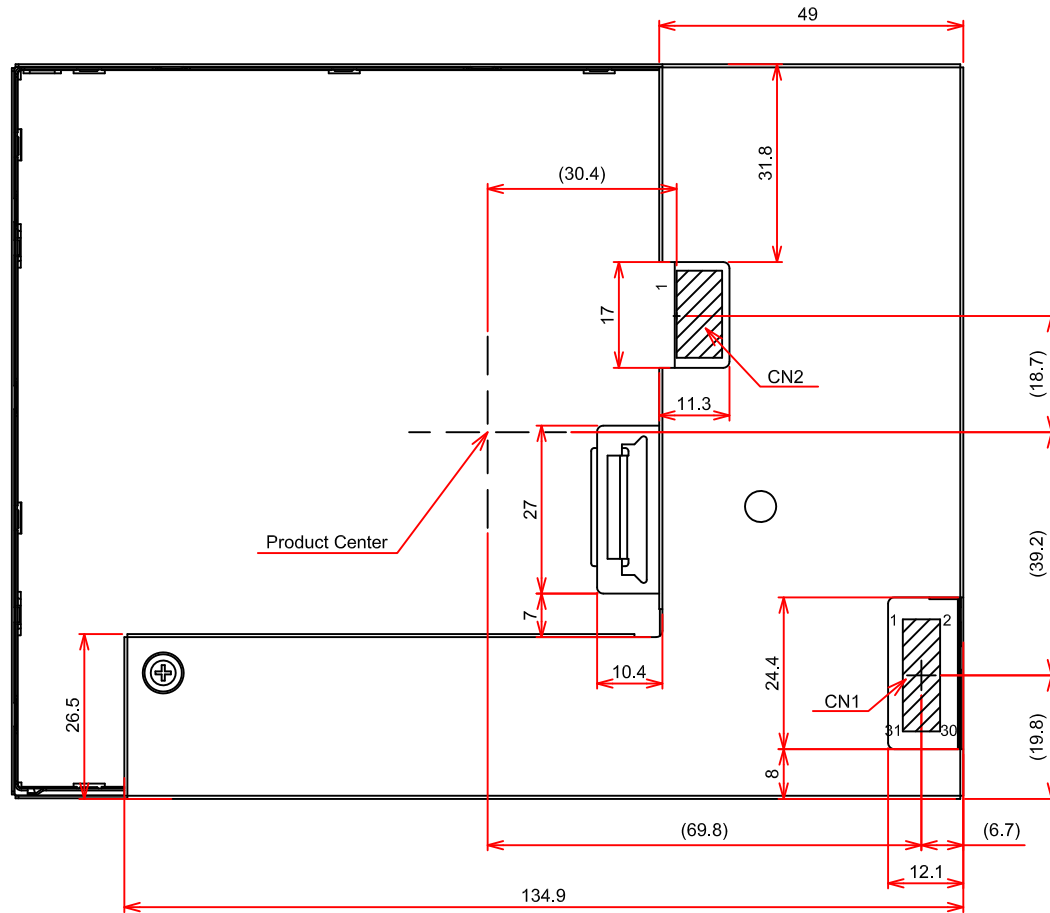

Note 1: General tolerance ± 0.5

Scale : NTS
Unit : mm

11. APPEARANCE STANDARD

The appearance inspection is performed in a dark room around 500~1000 lx based on the conditions as below:

- The distance between inspector's eyes and display is 30 cm.
- The viewing zone is defined with angle θ shown in Fig. 11.1 The inspection should be performed within 45° when display is shut down. The inspection should be performed within 5° when display is power on.

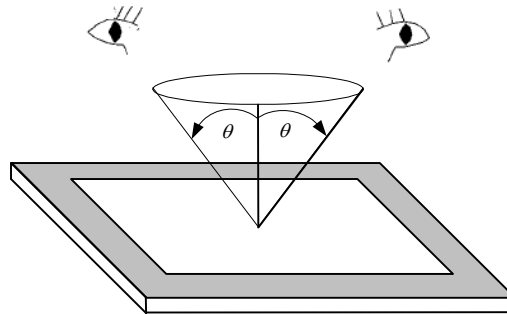

Fig. 11.1

11.1 THE DEFINITION OF LCD ZONE

LCD panel is divided into 3 areas as shown in Fig.11.2 for appearance specification in next section. A zone is the LCD active area (dot area); B zone is the area, which extended 1 mm out from LCD active area; C zone is the area between B zone and metal frame.

In terms of housing design, B zone is the recommended window area customers' housing should be located in.

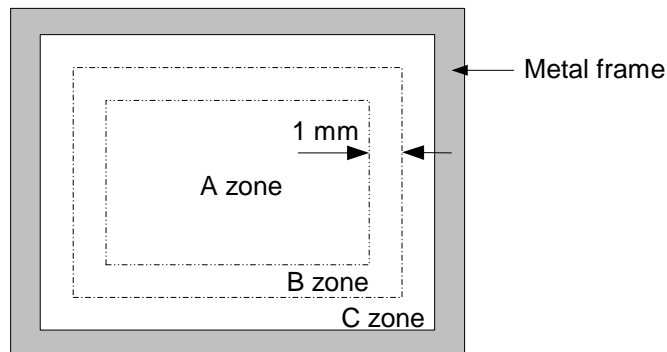

Fig. 11.2

11.2 LCD APPEARANCE SPECIFICATION

The specification as below is defined as the amount of unexpected phenomenon or material in different zones of LCD panel. The definitions of length, width and average diameter using in the table are shown in Fig. 11.3 and Fig. 11.4.

Item	Criteria				Applied zone
	Length (mm)	Width (mm)	Maximum number	Minimum space	
Scratches	Ignored	$W \leq 0.02$	Ignored	-	A, B
	$L \leq 40$	$0.02 < W \leq 0.04$	10	-	
	$L \leq 20$	$W \leq 0.04$	10	-	
	Serious one is not allowed				
Dent	Serious one is not allowed				A
Wrinkles in polarizer	Serious one is not allowed				A
Bubbles on polarizer	Average diameter (mm)		Maximum number		A
	$D \leq 0.3$		Ignored		
	$0.3 < D \leq 0.5$		12		
	$0.5 < D$		3		
1) Stains 2) Foreign Materials 3) Dark Spot	Filamentous (Line shape)				A, B
	Length (mm)	Width (mm)	Maximum number		
	$L \leq 2.0$	$W \leq 0.03$	Ignored		
	$L \leq 3.0$	$0.03 < W \leq 0.05$	10		
	$L \leq 2.5$	$0.05 < W \leq 0.1$	1		
	Round (Dot shape)				A, B
	Average diameter (mm)		Maximum number	Minimum Space	
	$D < 0.2$		Ignored	-	
	$0.2 \leq D < 0.3$		10	10 mm	
	$0.3 \leq D < 0.4$		5	30 mm	
	$0.4 \leq D$		None	-	
	In total		Filamentous + Round=10		
	Those wiped out easily are acceptable				
	Dot-Defect (Note 1)	Bright dot-defect		Type	Maximum number
1 dot				4	
2 adjacent dot				1	
3 adjacent dot or above				Not allowed	
In total				5	
Dark dot-defect		1 dot	5		
		2 adjacent dot	2		
		3 adjacent dot or above	Not allowed		
		In total	5		
In total		10			

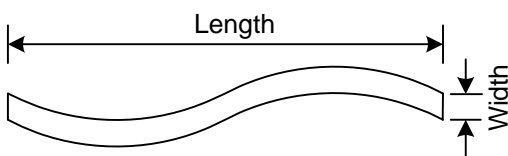
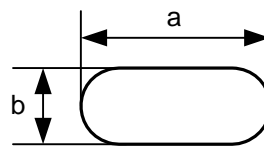

Fig. 11.3



$$\text{Average diameter} = \frac{a+b}{2}$$

Fig. 11.4

Note 1: The definitions of dot defect are as below:

- The defect area of the dot must be bigger than half of a dot.
- For bright dot-defect, showing black pattern, the dot's brightness must be over 30% brighter than others.
- For dark dot-defect, showing white pattern, the dot's brightness must be under 70% darker than others.
- The definition of 1-dot-defect is the defect-dot, which is isolated and no adjacent defect-dot.
- The definition of adjacent dot is shown as Fig. 11.5.

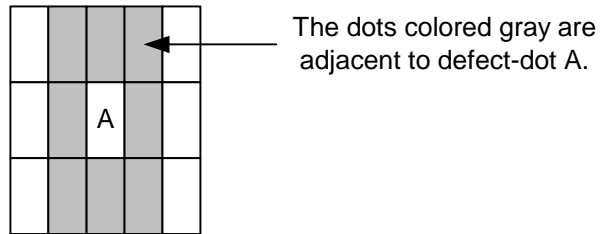

Fig. 11.5

12. PRECAUTIONS

12.1 PRECAUTIONS of ESD

- 1) Before handling the display, please ensure your body has been connected to ground to avoid any damages by ESD. Also, do not touch display's interface directly when assembling.
- 1) Please remove the protection film very slowly before turning on the display to avoid generating ESD.

12.2 PRECAUTIONS of HANDLING

- 1) In order to keep the appearance of display in good condition, please do not rub any surfaces of the displays by using sharp tools harder than 3H, especially touch panel, metal frame and polarizer.
- 2) Please do not stack the displays as this may damage the surface. In order to avoid any injuries, please avoid touching the edge of the glass or metal frame and wore gloves during handling.
- 2) Touching the polarizer or terminal pins with bare hand should be avoided to prevent staining and poor electrical contact.
- 3) Do not use any harmful chemicals such as acetone, toluene, and isopropyl alcohol to clean display's surfaces.
- 4) Please use soft cloth or absorbent cotton with ethanol to clean the display by gently wiping. Moreover, when wiping the display, please wipe it by horizontal or vertical direction instead of circling to prevent leaving scars on the display's surface, especially polarizer.
- 5) Please wipe any unknown liquids immediately such as saliva, water or dew on the display to avoid color fading or any permanent damages.
- 6) Maximum pressure to the surface of the display must be less than 1.96×10^4 Pa. If the area of applied pressure is less than 1 cm^2 , the maximum pressure must be less than 1.96N.

12.3 PRECAUTIONS OF OPERATING

- 1) Please input signals and voltages to the displays according to the values defined in the section of electrical characteristics to obtain the best performance. Any voltages over than absolute maximum rating will cause permanent damages to this display. Also, any timing of the signals out of this specification would cause unexpected performance.
- 2) When the display is operating at significant low temperature, the response time will be slower than it at 25 C° . In high temperature, the color will be slightly dark and blue compared to original pattern. However, these are temperature-related phenomenon of LCD and it will not cause permanent damages to the display when used within the operating temperature.
- 3) The use of screen saver or sleep mode is recommended when static images are likely for long periods of time. This is to avoid the possibility of image sticking.
- 4) Spike noise can cause malfunction of the circuit. The recommended limitation of spike noise is no bigger than $\pm 100 \text{ mV}$.

12.4 PRECAUTIONS of STORAGE

If the displays are going to be stored for years, please be aware the following notices.

- 1) Please store the displays in a dark room to avoid any damages from sunlight and other sources of UV light.
- 2) The recommended long term storage temperature is between 10°C~35°C and 55%~75% humidity to avoid causing bubbles between polarizer and LCD glasses, and polarizer peeling from LCD glasses.
- 3) It would be better to keep the displays in the container, which is shipped from KOE, and do not unpack it.
- 4) Please do not stick any labels on the display surface for a long time, especially on the polarizer.

13. DESIGNATION of LOT MARK

1) The lot mark is showing in Fig.13.1. First 4 digits are used to represent production lot, T represented made in Taiwan, and the last 6 digits are the serial number.

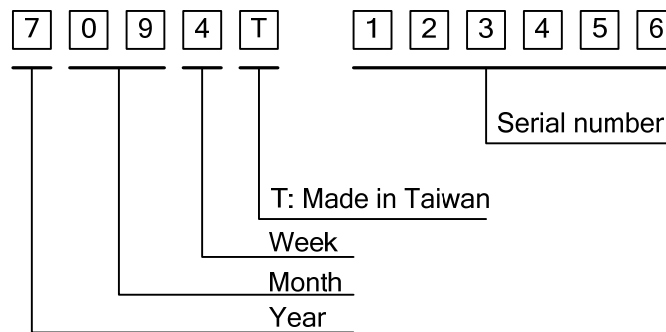

Fig. 13.1

2) The tables as below are showing what the first 4 digits of lot mark are shorted for.

Year	Lot Mark
2017	7
2018	8
2019	9
2020	0
2021	1

Month	Lot Mark	Month	Lot Mark
Jan.	01	Jul.	07
Feb.	02	Aug.	08
Mar.	03	Sep.	09
Apr.	04	Oct.	10
May	05	Nov.	11
Jun.	06	Dec.	12

Week	Lot Mark
1~7 days	1
8~14 days	2
15~21 days	3
22~28 days	4
29~31 days	5

3) Except letters I and O, revision number will be shown on lot mark and following letters A to Z.

REV.No	ITEM	REMARKS
A	-	-
B	LCD source changed	PCN 0976

4) The location of the lot mark is on the back of the display shown in Fig. 13.2.

Label example:



Fig. 13.2