

KOE

JDI Group

Kaohsiung Opto-Electronics Inc.

FOR MESSRS : _____

DATE : Jun. 6th, 2017

CUSTOMER'S ACCEPTANCE SPECIFICATIONS

TX18D206VM0BAA

Contents

No.	ITEM	SHEET No.	PAGE
1	COVER	7B64PS 2701-TX18D206VM0BAA-7	1-1/1
2	RECORD OF REVISION	7B64PS 2702-TX18D206VM0BAA-7	2-1/3~3/3
3	GENERAL DATA	7B64PS 2703-TX18D206VM0BAA-7	3-1/1
4	ABSOLUTE MAXIMUM RATINGS	7B64PS 2704-TX18D206VM0BAA-7	4-1/1
5	ELECTRICAL CHARACTERISTICS	7B64PS 2705-TX18D206VM0BAA-7	5-1/2~2/2
6	OPTICAL CHARACTERISTICS	7B64PS 2706-TX18D206VM0BAA-7	6-1/2~2/2
7	BLOCK DIAGRAM	7B64PS 2707-TX18D206VM0BAA-7	7-1/1
8	RELIABILITY TESTS	7B64PS 2708-TX18D206VM0BAA-7	8-1/1
9	LCD INTERFACE	7B64PS 2709-TX18D206VM0BAA-7	9-1/8~8/8
10	OUTLINE DIMENSIONS	7B64PS 2710-TX18D206VM0BAA-7	10-1/2~2/2
11	APPEARANCE STANDARD	7B64PS 2711-TX18D206VM0BAA-7	11-1/3~3/3
12	PRECAUTIONS	7B64PS 2712-TX18D206VM0BAA-7	12-1/2~2/2
13	DESIGNATION OF LOT MARK	7B64PS 2713-TX18D206VM0BAA-7	13-1/1

ACCEPTED BY: _____

PROPOSED BY: Oblack Tsai

2. RECORD OF REVISION

DATE	SHEET No.	SUMMARY																																								
Aug.7.'15	7B64PS 2709 – TX18D206VM0BAA-2 PAGE 9-1/8	<p>9.1 INTERFACE PIN CONNECTIONS</p> <p>Revised :</p> <table border="1"> <tr> <td>11</td> <td>IN2-</td> <td rowspan="2">B2~B5, DE</td> </tr> <tr> <td>12</td> <td>IN2+</td> </tr> <tr> <td>17</td> <td>IN3-</td> <td rowspan="2">R6~R7, G6~G7, B6~B7</td> </tr> <tr> <td>18</td> <td>IN3+</td> </tr> <tr> <td>19</td> <td>V_{LED}</td> <td>12 VDC</td> </tr> </table> <p style="text-align: center;">↓</p> <table border="1"> <tr> <td>11</td> <td>IN2-</td> <td rowspan="2">B2~B5, DE, VS, HS</td> </tr> <tr> <td>12</td> <td>IN2+</td> </tr> <tr> <td>17</td> <td rowspan="3">NC</td> <td rowspan="3">No Connection</td> </tr> <tr> <td>18</td> </tr> <tr> <td>19</td> </tr> </table>	11	IN2-	B2~B5, DE	12	IN2+	17	IN3-	R6~R7, G6~G7, B6~B7	18	IN3+	19	V _{LED}	12 VDC	11	IN2-	B2~B5, DE, VS, HS	12	IN2+	17	NC	No Connection	18	19																	
11	IN2-	B2~B5, DE																																								
12	IN2+																																									
17	IN3-	R6~R7, G6~G7, B6~B7																																								
18	IN3+																																									
19	V _{LED}	12 VDC																																								
11	IN2-	B2~B5, DE, VS, HS																																								
12	IN2+																																									
17	NC	No Connection																																								
18																																										
19																																										
7B64PS 2709 – TX18D206VM0BAA-2 PAGE 9-2/8	<p>9.2 LVDS INTERFACE</p> <p>Revised :</p>																																									
Feb.2,'16	7B64PS 2706 – TX18D206VM0BAA-3 PAGE 6-1/2	<p>6. OPTICAL CHARACTERISTICS</p> <p>Revised :</p> <table border="1"> <thead> <tr> <th>Item</th> <th>Symbol</th> <th>Min.</th> <th>Typ.</th> <th>Max.</th> </tr> </thead> <tbody> <tr> <td rowspan="3">Color Chromaticity</td> <td>Red</td> <td>y</td> <td>0.28</td> <td>0.33</td> <td>0.38</td> </tr> <tr> <td rowspan="2">White</td> <td>x</td> <td>0.27</td> <td>0.32</td> <td>0.37</td> </tr> <tr> <td>y</td> <td>0.30</td> <td>0.35</td> <td>0.40</td> </tr> </tbody> </table> <p style="text-align: center;">↓</p> <table border="1"> <thead> <tr> <th>Item</th> <th>Symbol</th> <th>Min.</th> <th>Typ.</th> <th>Max.</th> </tr> </thead> <tbody> <tr> <td rowspan="3">Color Chromaticity</td> <td>Red</td> <td>y</td> <td>0.27</td> <td>0.32</td> <td>0.37</td> </tr> <tr> <td rowspan="2">White</td> <td>x</td> <td>0.26</td> <td>0.31</td> <td>0.36</td> </tr> <tr> <td>y</td> <td>0.28</td> <td>0.33</td> <td>0.38</td> </tr> </tbody> </table>	Item	Symbol	Min.	Typ.	Max.	Color Chromaticity	Red	y	0.28	0.33	0.38	White	x	0.27	0.32	0.37	y	0.30	0.35	0.40	Item	Symbol	Min.	Typ.	Max.	Color Chromaticity	Red	y	0.27	0.32	0.37	White	x	0.26	0.31	0.36	y	0.28	0.33	0.38
Item	Symbol	Min.	Typ.	Max.																																						
Color Chromaticity	Red	y	0.28	0.33	0.38																																					
	White	x	0.27	0.32	0.37																																					
		y	0.30	0.35	0.40																																					
Item	Symbol	Min.	Typ.	Max.																																						
Color Chromaticity	Red	y	0.27	0.32	0.37																																					
	White	x	0.26	0.31	0.36																																					
		y	0.28	0.33	0.38																																					

2. RECORD OF REVISION

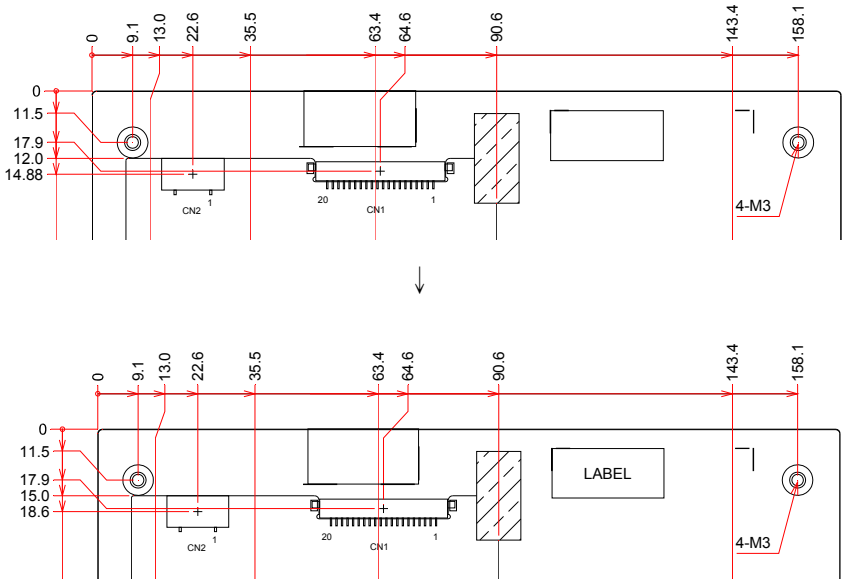
DATE	SHEET No.	SUMMARY
Feb.2,'16	7B64PS 2710 – TX18D206VM0BAA-3 PAGE 10-2/2	<p>10.2 REAR VIEW Revised :</p> 
Jun.1,'16	7B64PS 2705 – TX18D206VM0BAA-4 PAGE 5-1/2	5.1 LCD CHARACTERISTICS Revised : Note 1
	7B64PS 2705 – TX18D206VM0BAA-4 PAGE 5-2/2	5.2 BACKLIGHT CHARACTERISTICS Revised : Note 3 Fig1

2. RECORD OF REVISION

DATE	SHEET No.	SUMMARY																																																																													
Feb.1,'17	7B64PS 2711 – TX18D206VM0BAA-5 PAGE 11-2/3~3/3	<p>11.2 LCD APPEARANCE SPECIFICATION Revised :</p> <table border="1"> <thead> <tr> <th rowspan="2">Dot-Defect (Note 1)</th> <th rowspan="2">Type</th> <th colspan="2">Maximum number</th> <th rowspan="2">A</th> </tr> <tr> <th></th> <th></th> </tr> </thead> <tbody> <tr> <td rowspan="5">Bright dot-defect</td> <td>1 dot</td> <td></td> <td>4</td> <td rowspan="5"></td> </tr> <tr> <td>2 adjacent dot</td> <td></td> <td>1</td> </tr> <tr> <td>3 adjacent dot or above</td> <td></td> <td>Not allowed</td> </tr> <tr> <td>Density</td> <td></td> <td>2(ϕ 20mm)</td> </tr> <tr> <td>In total</td> <td></td> <td>5</td> </tr> <tr> <td rowspan="5">Dark dot-defect</td> <td>1 dot</td> <td></td> <td>5</td> <td rowspan="5"></td> </tr> <tr> <td>2 adjacent dot</td> <td></td> <td>2</td> </tr> <tr> <td>3 adjacent dot or above</td> <td></td> <td>Not allowed</td> </tr> <tr> <td>Density</td> <td></td> <td>3(ϕ 20mm)</td> </tr> <tr> <td>In total</td> <td></td> <td>5</td> </tr> <tr> <td colspan="2">In total</td> <td></td> <td>10</td> <td></td> </tr> </tbody> </table> <p style="text-align: center;">↓</p> <table border="1"> <thead> <tr> <th rowspan="2">Dot-Defect (Note 1)</th> <th rowspan="2">Type</th> <th colspan="2">Maximum number</th> <th rowspan="2">A</th> </tr> <tr> <th></th> <th></th> </tr> </thead> <tbody> <tr> <td rowspan="2">Bright dot-defect</td> <td>1 dot</td> <td></td> <td>0</td> <td rowspan="2"></td> </tr> <tr> <td></td> <td></td> <td></td> </tr> <tr> <td rowspan="3">Dark dot-defect</td> <td>1 dot</td> <td></td> <td>4</td> <td rowspan="3"></td> </tr> <tr> <td>2 dots</td> <td></td> <td>1(sets)</td> </tr> <tr> <td>In total</td> <td></td> <td>4</td> </tr> <tr> <td colspan="2">In total</td> <td></td> <td>4</td> <td></td> </tr> </tbody> </table> <p>Note 1 : Revise The definitions of dot defect</p>	Dot-Defect (Note 1)	Type	Maximum number		A			Bright dot-defect	1 dot		4		2 adjacent dot		1	3 adjacent dot or above		Not allowed	Density		2(ϕ 20mm)	In total		5	Dark dot-defect	1 dot		5		2 adjacent dot		2	3 adjacent dot or above		Not allowed	Density		3(ϕ 20mm)	In total		5	In total			10		Dot-Defect (Note 1)	Type	Maximum number		A			Bright dot-defect	1 dot		0					Dark dot-defect	1 dot		4		2 dots		1(sets)	In total		4	In total			4	
Dot-Defect (Note 1)	Type	Maximum number			A																																																																										
Bright dot-defect	1 dot		4																																																																												
	2 adjacent dot		1																																																																												
	3 adjacent dot or above		Not allowed																																																																												
	Density		2(ϕ 20mm)																																																																												
	In total		5																																																																												
Dark dot-defect	1 dot		5																																																																												
	2 adjacent dot		2																																																																												
	3 adjacent dot or above		Not allowed																																																																												
	Density		3(ϕ 20mm)																																																																												
	In total		5																																																																												
In total			10																																																																												
Dot-Defect (Note 1)	Type	Maximum number		A																																																																											
Bright dot-defect	1 dot		0																																																																												
Dark dot-defect	1 dot		4																																																																												
	2 dots		1(sets)																																																																												
	In total		4																																																																												
In total			4																																																																												
May 8,'17	7B64 2709 – TX18D206VM0BAA-6 Page 9-5/8	9.3 TIMING TABLE Added Note 1~2																																																																													
Jun. 6,'17	7B64 2709 – TX18D206VM0BAA-7 Page 9-2/8	9.2 LVDS INTERFACE Revised : THC63LVDM84B → THC63LVDF84B																																																																													

3. GENERAL DATA

3.1 DISPLAY FEATURES

This module is a 7" WVGA of 16:9 format amorphous silicon TFT. The pixel format is vertical stripe and sub pixels are arranged as R (red), G (green), B (blue) sequentially. This display is RoHS compliant, COG (chip on glass) technology and LED backlight are applied on this display.

Part Name	TX18D206VM0BAA
Module Dimensions	167.7(W) mm x 109.5(H) mm x 9.0 (D) mm
LCD Active Area	152.4(W) mm x 91.44(H) mm
Pixel Pitch	0.1905(W) mm x 0.1905 (H) mm
Resolution	800 x 3(RGB)(W) x 480(H) Dots
Color Pixel Arrangement	R, G, B Vertical Stripe
LCD Type	Transmissive Color TFT; Normally Black
Display Type	Active Matrix
Number of Colors	262k Colors (6-bit RGB)
Backlight	Light Emitting Diode (LED)
Weight	231 g
Interface	LVDS; 20 pins
Power Supply Voltage	3.3V for LCD; 12V for Backlight
Power Consumption	0.45W for LCD; 3.96W for Backlight
Viewing Direction	Super Wide Version (In-Plane Switching)

4. ABSOLUTE MAXIMUM RATINGS

Item	Symbol	Min.	Max.	Unit	Remarks
Supply Voltage	V_{DD}	-0.3	4.0	V	-
Input Voltage of Logic	V_I	-0.3	$V_{DD}+0.3$	V	Note 1
Operating Temperature	Top	-40	85	°C	Note 2
Storage Temperature	Tst	-40	90	°C	Note 2
Backlight Input Voltage	V_{LED}	-	14	V	-

Note 1: The rating is defined for the signal voltages of the interface such as CLK and pixel data pairs.

Note 2: The maximum rating is defined as above based on the chamber temperature, which might be different from ambient temperature after assembling the panel into the application. Moreover, some temperature-related phenomenon as below needed to be noticed:

- Background color, contrast and response time would be different in temperatures other than 25°C.
- Operating under high temperature will shorten LED lifetime.

5. ELECTRICAL CHARACTERISTICS

5.1 LCD CHARACTERISTICS

$T_a = 25\text{ }^\circ\text{C}$, $V_{SS} = 0\text{V}$

Item	Symbol	Condition	Min.	Typ.	Max.	Unit	Remarks
Power Supply Voltage	V_{DD}	-	3.0	3.3	3.6	V	-
Differential Input Voltage for LVDS Receiver Threshold	V_I	"H" level	-	-	+100	mV	Note 1
		"L" level	-100	-	-		
Power Supply Current	I_{DD}	$V_{DD}=3.3\text{V}$	-	136	170	mA	Note 2
Frame Frequency	f_{Frame}	-	-	60	65	Hz	
CLK Frequency	f_{CLK}	-	31.5	33.3	36	MHz	

Note 1: VCM 1.2V is common mode voltage of LVDS transmitter and receiver. The input terminal of LVDS transmitter is terminated with 100Ω .

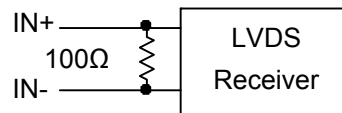

Note 2: An all white check pattern is used when measuring I_{DD} . f_{Frame} is set to 60 Hz. Moreover, 1.0A fuse is applied in the module for I_{DD} . For display activation and protection purpose, power supply is recommended larger than 2.5A to start the display and break fuse once any short circuit occurred.

5.2 BACKLIGHT CHARACTERISTICS

$T_a = 25^\circ\text{C}$

Item	Symbol	Condition	Min.	Typ.	Max.	Unit	Remarks
LED Input Voltage	V_{LED}	-	11.0	12.0	13.0	V	Note1
LED Forward Current (Dim Control)	I_{LED}	0V; 0% duty	-	330	360	mA	Note 2
		3.3VDC; 100% duty	10	20	30		
LED lifetime	-	$I_{LED} = 330\text{ mA}$	-	70K	-	hrs	Note 3

Note 1: As Fig. 5.1 shown, LED current is constant, 330 mA, controlled by the LED driver when applying 12V.

Note 2: Dimming function can be obtained by applying DC voltage or PWM signal from the display interface CN1. The recommended PWM signal is 1K ~ 10K Hz with 3.3V amplitude.

Note 3: The estimated lifetime is specified as the time to reduce 50% brightness by applying 330 mA at 25°C .

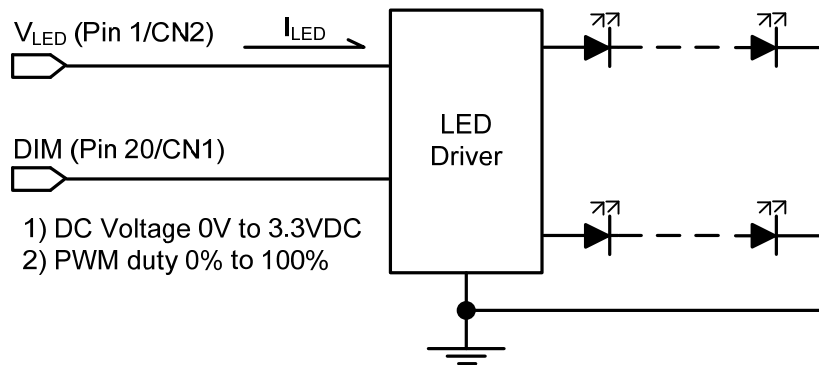

Fig 5.1

6. OPTICAL CHARACTERISTICS

The optical characteristics are measured based on the conditions as below:

- Supplying the signals and voltages defined in the section of electrical characteristics.
- The backlight unit needs to be turned on for 30 minutes.
- The ambient temperature is 25 °C .
- In the dark room less than 100 lx, the equipment has been set for the measurements as shown in Fig 6.1.

$$T_a = 25\text{ }^{\circ}\text{C}, f_{Frame} = 60\text{ Hz}, V_{DD} = 3.3\text{ V}$$

Item	Symbol	Condition	Min.	Typ.	Max.	Unit	Remarks
Brightness of White	-	$\phi = 0^{\circ}, \theta = 0^{\circ}$, $I_{LED} = 330\text{ mA}$	640	800	-	cd/m ²	Note 1
Brightness Uniformity	-		70	-	-	%	Note 2
Contrast Ratio	CR		700	1000	-	-	Note 3
Response Time	$T_r + T_f$	$\phi = 0^{\circ}, \theta = 0^{\circ}$	-	30	40	ms	Note 4
NTSC Ratio	-	$\phi = 0^{\circ}, \theta = 0^{\circ}$	-	70	-	%	-
Viewing Angle	θ_x	$\phi = 0^{\circ}, CR \geq 10$	-	85	-	Degree	Note 5
	$\theta_{x'}$	$\phi = 180^{\circ}, CR \geq 10$	-	85	-		
	θ_y	$\phi = 90^{\circ}, CR \geq 10$	-	85	-		
	$\theta_{y'}$	$\phi = 270^{\circ}, CR \geq 10$	-	85	-		
Color Chromaticity	Red	X	0.60	0.65	0.70	-	Note 6
		Y	0.27	0.32	0.37		
	Green	X	0.27	0.32	0.37		
		Y	0.56	0.61	0.66		
	Blue	X	0.10	0.15	0.20		
		Y	0.01	0.06	0.11		
	White	X	0.26	0.31	0.36		
		Y	0.28	0.33	0.38		

Note 1: The brightness is measured from the center point of the panel, P5 in Fig. 6.2, for the typical value.

Note 2: The brightness uniformity is calculated by the equation as below:

$$\text{Brightness uniformity} = \frac{\text{Min. Brightness}}{\text{Max. Brightness}} \times 100\%$$

which is based on the brightness values of the 9 points in active area measured by BM-5 as shown in Fig. 6.2.

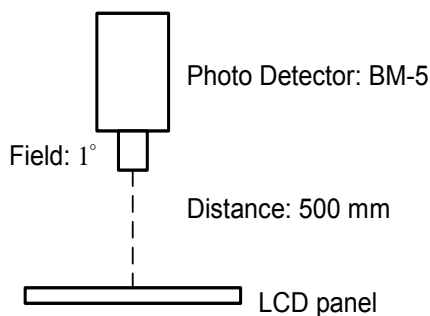

Fig 6.1

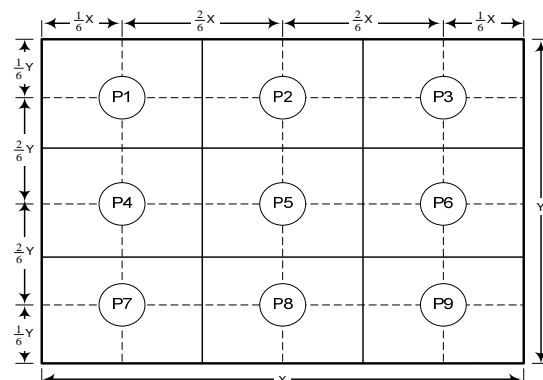

Fig 6.2

Note 3: The Contrast Ratio is measured from the center point of the panel, P5, and defined as the following equation:

$$CR = \frac{\text{Brightness of White}}{\text{Brightness of Black}}$$

Note 4: The definition of response time is shown in Fig. 6.3. The rising time is the period from 10% brightness to 90% brightness when the data is from black to white. Oppositely, Falling time is the period from 90% brightness falling to 10% brightness.

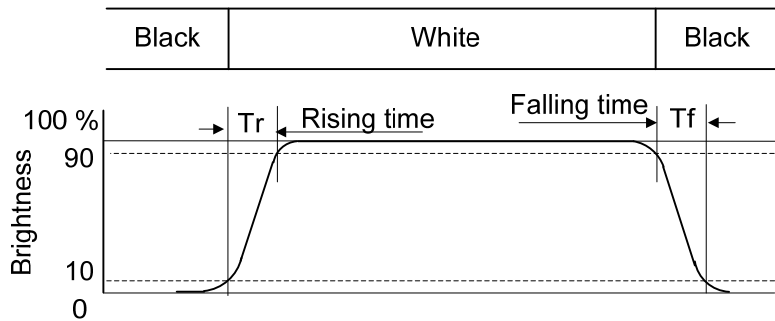

Fig.6.3

Note 5: The definition of viewing angle is shown in Fig. 6.4. Angle ϕ is used to represent viewing directions, for instance, $\phi = 270^\circ$ means 6 o'clock, and $\phi = 0^\circ$ means 3 o'clock. Moreover, angle θ is used to represent viewing angles from axis Z toward plane XY.

The display is super wide viewing angle version, so that the best optical performance can be obtained from every viewing direction.

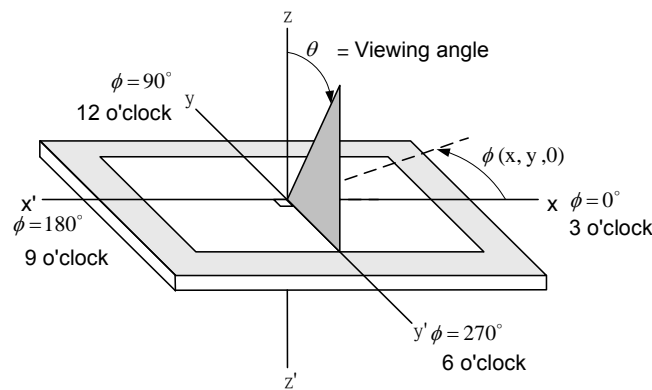
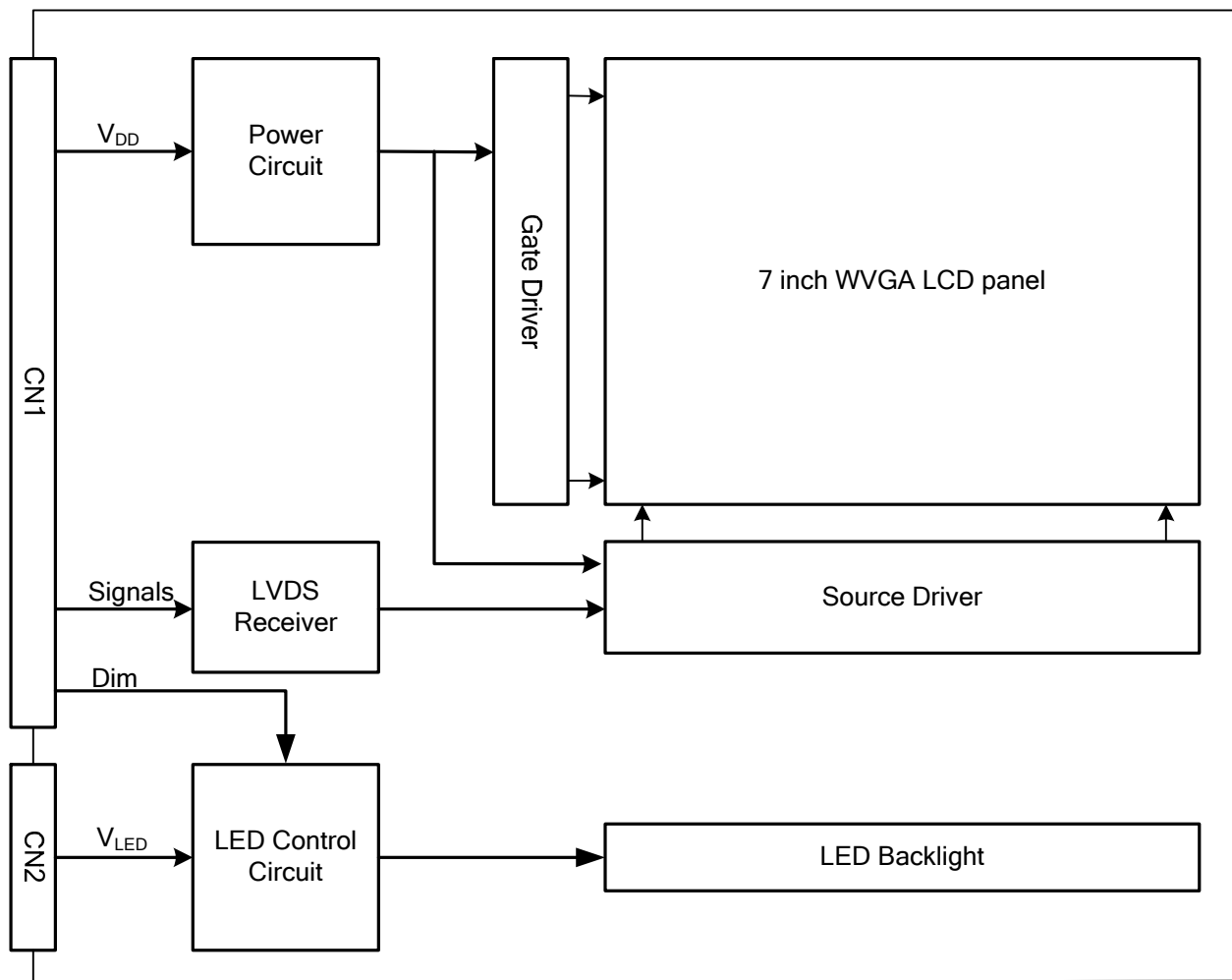

Fig 6.4

Note 6: The color chromaticity is measured from the center point of the panel, P5, as shown in Fig. 6.2.

7. BLOCK DIAGRAM



Note 1: Signals are CLK and pixel data pairs.

8. RELIABILITY TESTS

Test Item	Condition	
High Temperature	1) Operating 2) 85 °C	500 hrs
Low Temperature	1) Operating 2) -40 °C	500 hrs
High Temperature	1) Storage 2) 90 °C	500 hrs
Low Temperature	1) Storage 2) -40 °C	500 hrs
Heat Cycle	1) Operating 2) -40 °C ~85 °C 3) 3hrs~1hr~3hrs	500 hrs
Thermal Shock	1) Non-Operating 2) -40 °C ↔ 85 °C 3) 0.5 hr ↔ 0.5 hr	500 hrs
High Temperature & Humidity	1) Operating 2) 60 °C & 90%RH 3) Without condensation	500 hrs (Note 3)
Vibration	1) Non-Operating 2) 10~200 Hz 3) 5G 4) X, Y, and Z directions	1 hr for each direction
Mechanical Shock	1) Non-Operating 2) 10 ms 3) 80G 4) ±X, ±Y and ±Z directions	Once for each direction
ESD	1) Operating 2) Tip: 150 pF, 330 Ω 3) Air discharge for glass: ± 12KV 4) Contact discharge for metal frame: ± 15KV	1) Glass: 9 points 2) Metal frame: 8 points (Note4)

Note 1: Display functionalities are inspected under the conditions defined in the specification after the reliability tests.

Note 2: The display is not guaranteed for use in corrosive gas environments.

Note 3: Under the condition of high temperature & humidity, if the temperature is higher than 60°C, the humidity needs to be reduced as Fig. 8.1 shown.

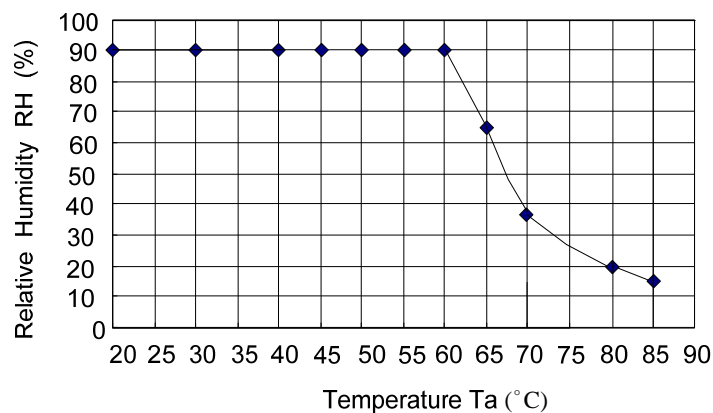

Fig. 8.1

Note 4: All pins of LCD interface (CN1) have been tested by ±100V contact discharge of ESD under non-operating condition.

9. LCD INTERFACE

9.1 INTERFACE PIN CONNECTIONS

The display interface connector (CN1) is FI-SEB20P-HF13E-E1500 made by JAE and pin assignment is as below:

Pin No.	Symbol	Signal	Pin No.	Symbol	Signal
1	V _{DD}	Power Supply for Logic	11	IN2-	B2~B5, DE, VS, HS
2	V _{DD}		12	IN2+	
3	LR	Horizontal Display mode Control	13	V _{SS}	GND
4	UD	Vertical synchronous signal	14	CLK IN-	Pixel Clock
5	IN0-	R0~R5, G0	15	CLK IN+	
6	IN0+		16	V _{SS}	GND
7	V _{SS}	GND	17	NC	No Connection
8	IN1-	G1~G5, B0~B1	18	NC	
9	IN1+		19	NC	
10	V _{SS}	GND	20	DIM	Note 2

Note 1: IN n- and IN n+ (n=0, 1, 2), CLK IN- and CLK IN+ should be wired by twist-pairs or side-by-side FPC patterns, respectively.

Note 2: Normal brightness: 0V or 0% PWM duty; Brightness control: 0V to 3.3V DC or 0% to 100% PWM duty.

Note 3: Please refer to [9.8 SCAN DIRECTION](#) for the setting methods of UD, LR function.

The backlight connector (CN2) is SM02 (8.0)B-BHS-1-TB(LF)(SN), and pin assignment is as below:

Pin No.	Signal	Signal
1	V _{LED}	12VDC
2	GND	Ground

9.2 LVDS INTERFACE

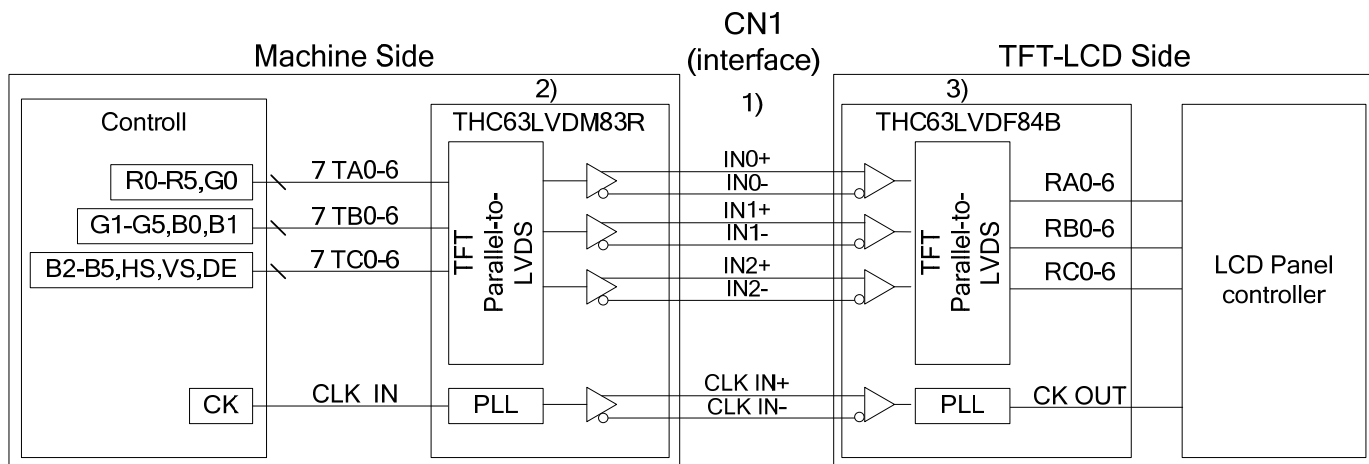

Note 1: LVDS cable impedance should be 100 ohms per signal line when each 2-lines (+, -) is used in differential mode.

Note 2: The recommended transmitter, THC63LVDM83R, is made by Thine or equivalent, which is not contained in the module.

9.3 LVDS DATA FORMAT

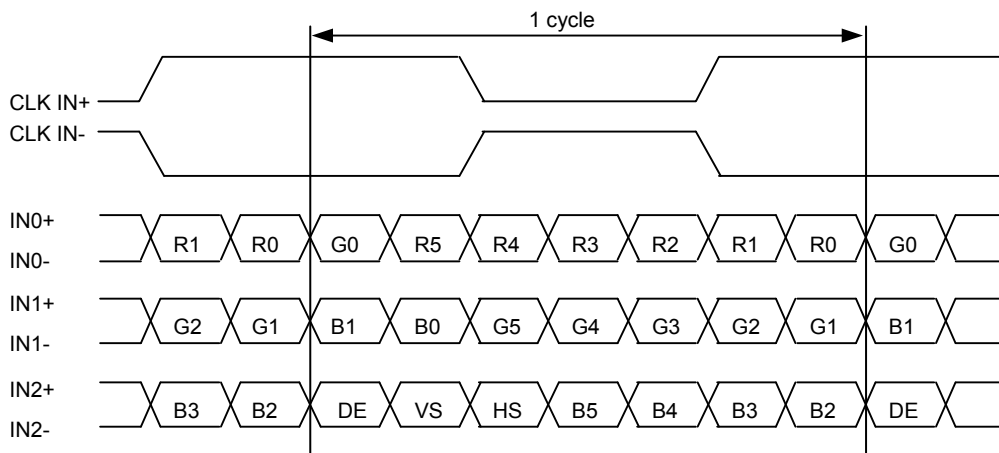

DE: Display Enable

HS: Horizontal synchronous signal

VS: Vertical synchronous signal

9.4 TIMING CHART

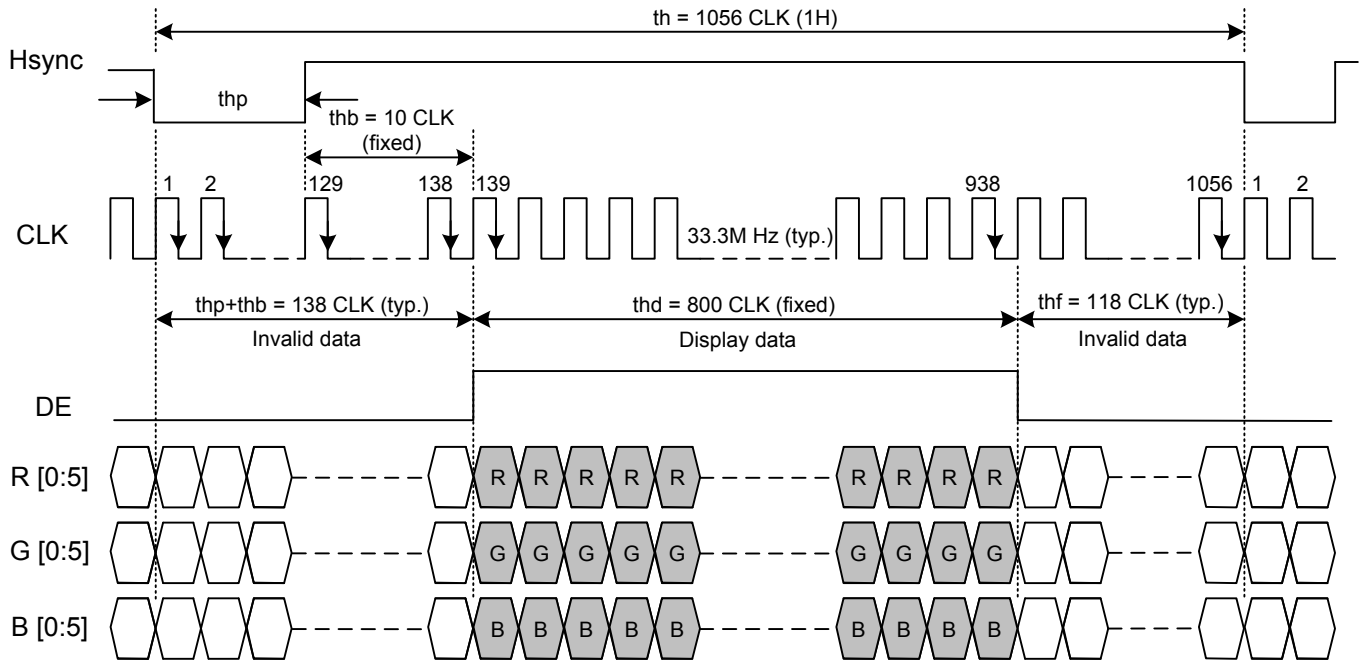

Fig. 9.1 Horizontal Timing

Note 1: CLK's falling edge is the time to latch data and count ($t_{hp} + t_{hb}$), therefore, data sending and Hsync's falling edge should start when CLK's rise edge.

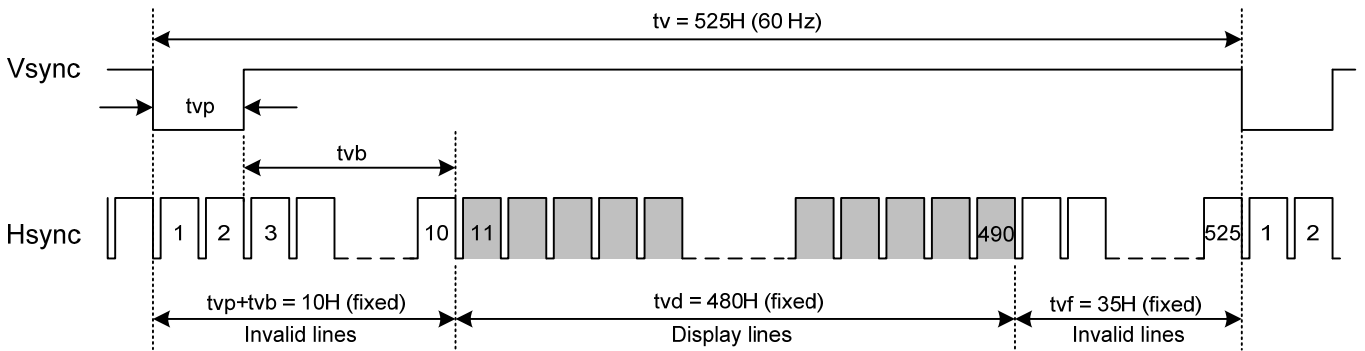

Fig. 9.2 Vertical Timing

Note 2: Vsync's falling edge needs to start with Hsync's falling edge simultaneously to count ($t_{vp} + t_{vb}$).

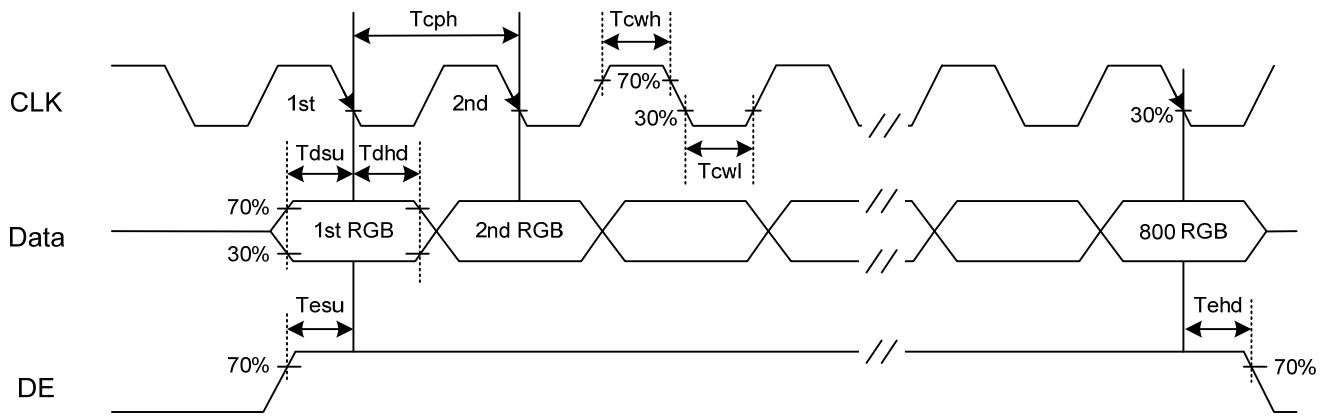

Fig. 9.3 Setup & Hold Time

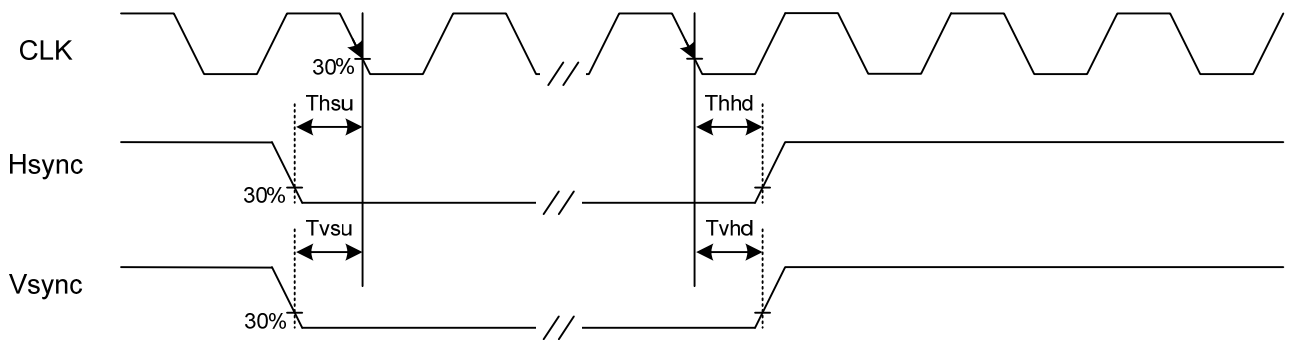

Fig. 9.4 Setup & Hold Time

9.5 TIMING TABLE

The column of timing sets including minimum, typical, and maximum as below are based on the best optical performance, frame frequency (f_{Frame}) = 60Hz to define. If 60 Hz is not the aim to set, less than 65 Hz for f_{Frame} is recommended to apply for better performance by other parameter combination as the definitions in section 5.1.

A. Horizontal and Vertical Timing

Item		Symbol	Min.	Typ.	Max.	Unit
Horizontal	CLK Frequency	fclk	31.5	33.3	36	MHz
	Display Data	thd	800			CLK
	Cycle Time	th	1000	1056	1144	
Vertical	Display Line	tvd	480			H
	Cycle Time	tv	525			

Note 1: tvp,tvb,tvd,tvf should keep all of following conditions

- a) $tvf \geq 4$ lines
- b) tvd + tvf should be ODD
- c) tvp + tvb should be EVEN
- d) The surplus of $(tvd + tvf - 2)/8$ should be equal or less than 3

Note 2: thp + thb should be equal or large than 26

B. CLOCK AND DATA INPUT TIMING

Item		Symbol	Min.	Typ.	Max.	Unit
CLK	Duty	Tcwh	46	50	52.5	%
	Cycle Time	Tcph	27.8	30	-	ns
Vsync	Setup Time	Tvsu	7	-	-	
	Hold Time	Tvhd	8	-	-	
Hsync	Setup Time	Thsu	8	-	-	
	Hold Time	Thhd	8	-	-	
Data	Setup Time	Tdsu	7	-	-	
	Hold Time	Tdhd	6	-	-	
DE	Setup Time	Tesu	8	-	-	
	Hold Time	Tehd	8	-	-	

9.6 LVDS RECEIVER TIMING

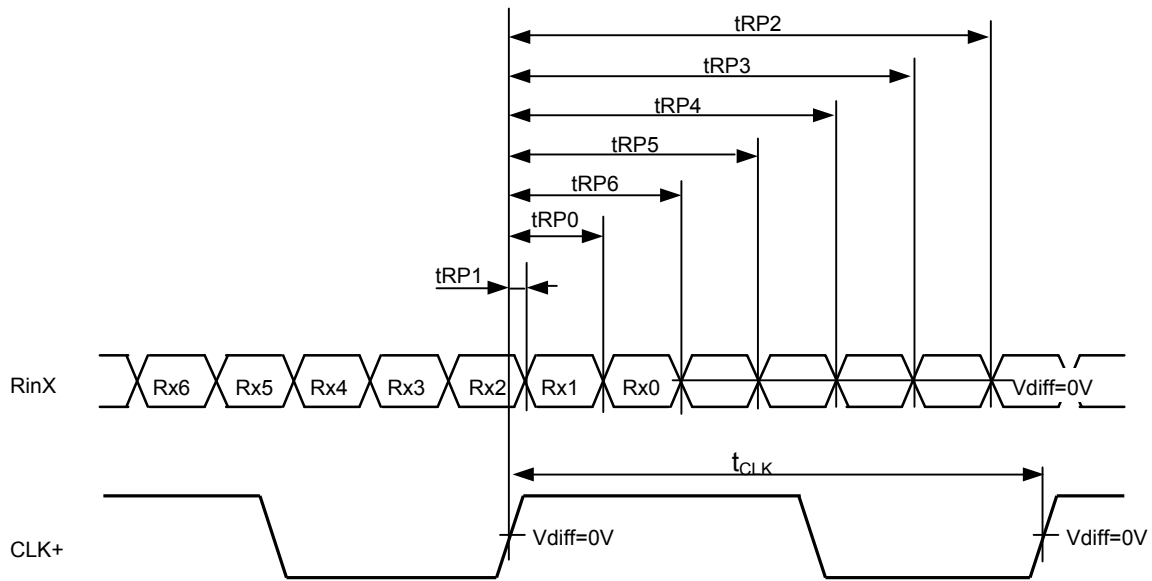

$$RinX = (RinX+) - (RinX-) \quad (X=0, 1, 2)$$

	Item	Symbol	Min.	Typ.	Max.	Unit
CLK	Cycle frequency	1/t _{CLK}	31.5	33.3	36	MHz
RinX (X=0,1,2)	0 data position	tRP0	1/7* t _{CLK} -0.49	1/7* t _{CLK}	1/7* t _{CLK} +0.49	ns
	1st data position	tRP1	-0.49	0	+0.49	
	2nd data position	tRP2	6/7* t _{CLK} -0.49	6/7* t _{CLK}	6/7* t _{CLK} +0.49	
	3rd data position	tRP3	5/7* t _{CLK} -0.49	5/7* t _{CLK}	5/7* t _{CLK} +0.49	
	4th data position	tRP4	4/7* t _{CLK} -0.49	4/7* t _{CLK}	4/7* t _{CLK} +0.49	
	5th data position	tRP5	3/7* t _{CLK} -0.49	3/7* t _{CLK}	3/7* t _{CLK} +0.49	
	6th data position	tRP6	2/7* t _{CLK} -0.49	2/7* t _{CLK}	2/7* t _{CLK} +0.49	

9.7 POWER SEQUENCE

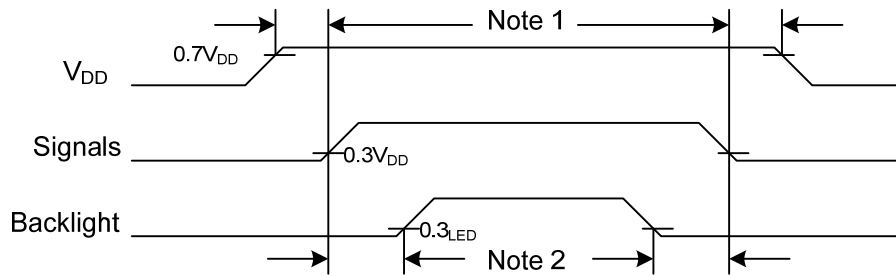

Note 1: In order to avoid any damages, V_{DD} has to be applied before all other signals. The opposite is true for power off where V_{DD} has to be remained on until all other signals have been switch off. The recommended time period is 1 second.

Note 2: In order to avoid showing uncompleted patterns in transient state. It is recommended that switching the backlight on is delayed for 1 second after the signals have been applied. The opposite is true for power off where the backlight has to be switched off 1 second before the signals are removed.

Note 3: In order to avoid high Inrush current, V_{DD} rising time need to set more than 0.5ms.

9.8 SCAN DIRECTION

Scan direction is available to be switched as below by setting CN1's UD & LR pin.

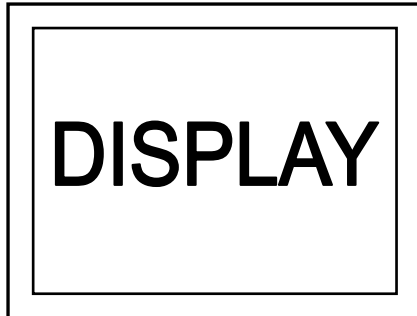

UD : L or Open ; LR : L or Open



UD : L or Open ; LR : H



UD : H ; LR : L or Open



UD : H ; LR : H

9.9 DATA INPUT for DISPLAY COLOR

Input color		Red Data						Green Data						Blue Data					
		R5	R4	R3	R2	R1	R0	G5	G4	G3	G2	G1	G0	B5	B4	B3	B2	B1	B0
		MSB			LSB			MSB			LSB			MSB				LSB	
Basic Color	Black	0	0	0	0	0	0	0	0	0	0	0	0	0	0	0	0	0	0
	Red(63)	1	1	1	1	1	1	0	0	0	0	0	0	0	0	0	0	0	0
	Green(63)	0	0	0	0	0	0	1	1	1	1	1	1	0	0	0	0	0	0
	Blue(63)	0	0	0	0	0	0	0	0	0	0	0	0	1	1	1	1	1	1
	Cyan	0	0	0	0	0	0	1	1	1	1	1	1	1	1	1	1	1	1
	Magenta	1	1	1	1	1	1	0	0	0	0	0	0	1	1	1	1	1	1
	Yellow	1	1	1	1	1	1	1	1	1	1	1	1	0	0	0	0	0	0
	White	1	1	1	1	1	1	1	1	1	1	1	1	1	1	1	1	1	1
Red	Black	0	0	0	0	0	0	0	0	0	0	0	0	0	0	0	0	0	0
	Red (1)	0	0	0	0	0	1	0	0	0	0	0	0	0	0	0	0	0	0
	Red (2)	0	0	0	0	1	0	0	0	0	0	0	0	0	0	0	0	0	0
	:	:	:	:	:	:	:	:	:	:	:	:	:	:	:	:	:	:	:
	:	:	:	:	:	:	:	:	:	:	:	:	:	:	:	:	:	:	:
	Red (62)	1	1	1	1	1	0	0	0	0	0	0	0	0	0	0	0	0	0
	Red (63)	1	1	1	1	1	1	0	0	0	0	0	0	0	0	0	0	0	0
Green	Black	0	0	0	0	0	0	0	0	0	0	0	0	0	0	0	0	0	0
	Green (1)	0	0	0	0	0	0	0	0	0	0	1	0	0	0	0	0	0	0
	Green (2)	0	0	0	0	0	0	0	0	0	0	1	0	0	0	0	0	0	0
	:	:	:	:	:	:	:	:	:	:	:	:	:	:	:	:	:	:	:
	:	:	:	:	:	:	:	:	:	:	:	:	:	:	:	:	:	:	:
	Green (62)	0	0	0	0	0	0	1	1	1	1	1	0	0	0	0	0	0	0
	Green (63)	0	0	0	0	0	0	1	1	1	1	1	1	0	0	0	0	0	0
Blue	Black	0	0	0	0	0	0	0	0	0	0	0	0	0	0	0	0	0	0
	Blue (1)	0	0	0	0	0	0	0	0	0	0	0	0	0	0	0	0	0	1
	Blue (2)	0	0	0	0	0	0	0	0	0	0	0	0	0	0	0	0	1	0
	:	:	:	:	:	:	:	:	:	:	:	:	:	:	:	:	:	:	:
	:	:	:	:	:	:	:	:	:	:	:	:	:	:	:	:	:	:	:
	Blue (62)	0	0	0	0	0	0	0	0	0	0	0	0	1	1	1	1	1	0
	Blue (63)	0	0	0	0	0	0	0	0	0	0	0	0	1	1	1	1	1	1

Note 1: Definition of gray scale : Color(n) Number in parenthesis indicates gray scale level. Larger number corresponds to brighter level.

Note 2: Data Signal : 1 : High, 0 : Low

10. OUTLINE DIMENSIONS

10.1 FRONT VIEW

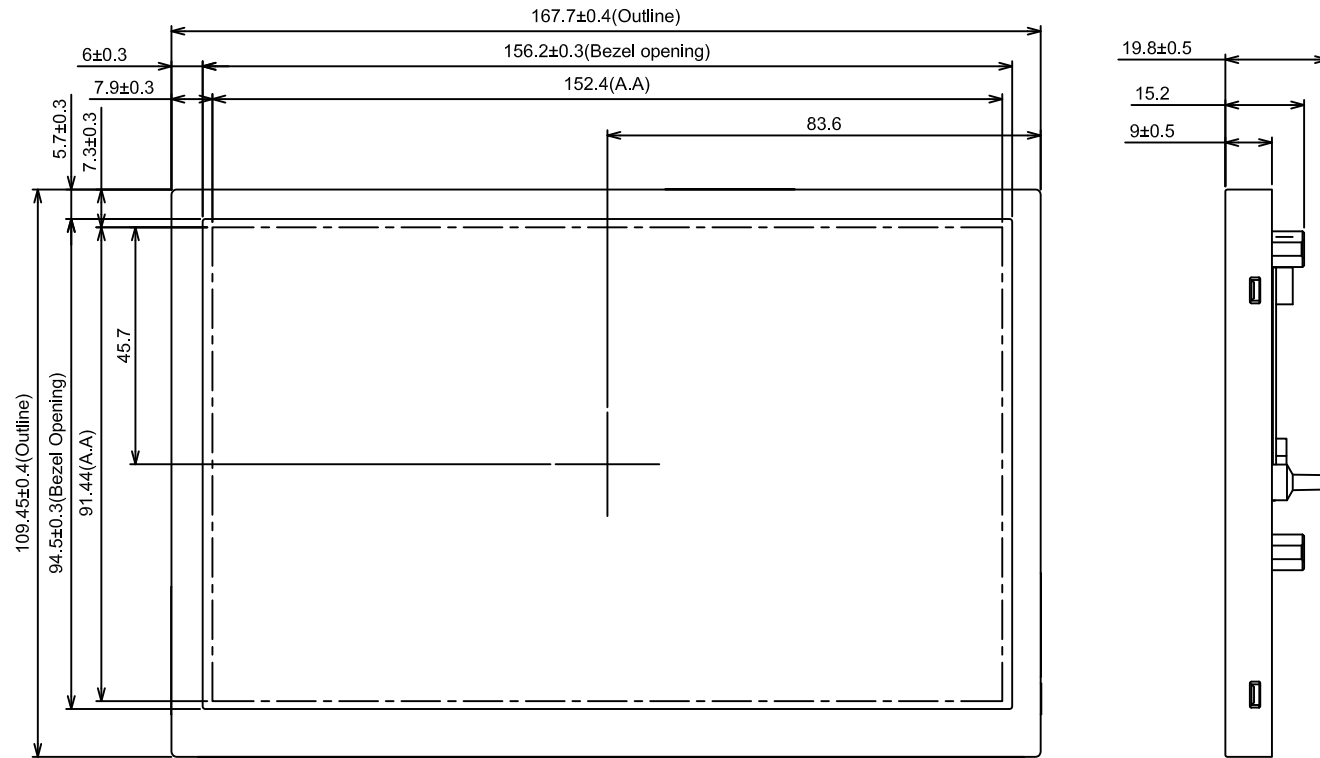

General Tolerance:±0.5mm
 Scale : NTS
 Unit : mm

10.2 REAR VIEW

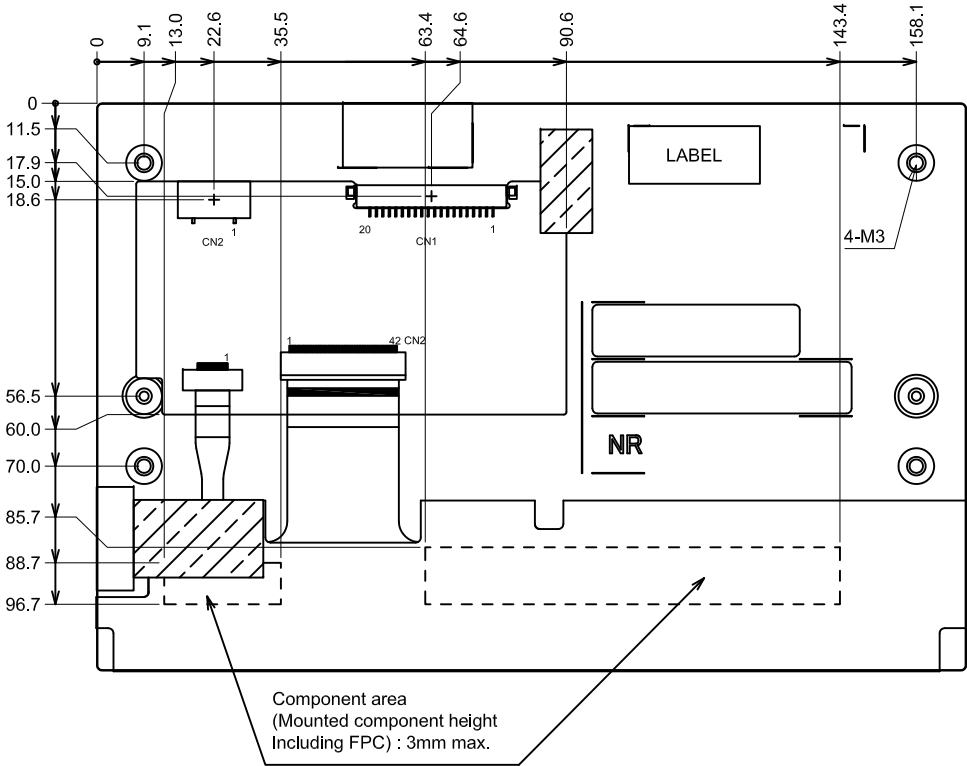

General Tolerance:±0.5mm
 Scale : NTS
 Unit : mm

11. APPEARANCE STANDARD

The appearance inspection is performed in a room around 500~1000 lx based on the conditions as below:

- The distance between inspector's eyes and display is 30 cm.
- The viewing zone is defined with angle θ shown in Fig. 11. The inspection should be performed within 45° when display is shut down. The inspection should be performed within 5° when display is power on.

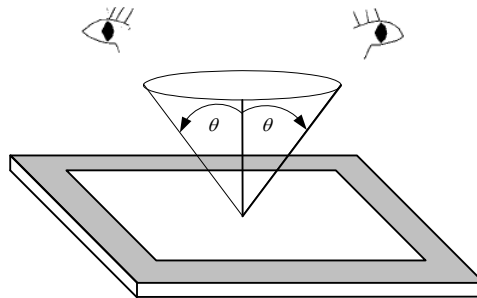

Fig. 11.1

11.1 THE DEFINITION OF LCD ZONE

LCD panel is divided into 2 areas as shown in Fig.11.2 for appearance specification in next section. A zone is the LCD active area (dot area); B zone is the area between A zone and metal frame.

In terms of housing design, B zone is the recommended window area customers' housing should be located in.

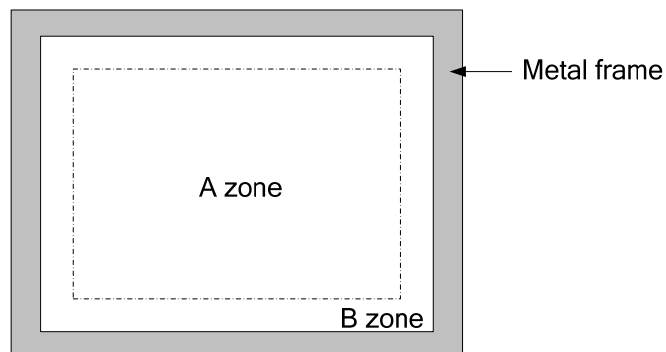

Fig. 11.2

11.2 LCD APPEARANCE SPECIFICATION

The specification as below is defined as the amount of unexpected phenomenon or material in different zones of LCD panel. The definitions of length, width and average diameter using in the table are shown in Fig. 11.3 and Fig. 11.4.

Item	Criteria				Applied zone
Scratches	Length (mm)	Width (mm)	Maximum number	Minimum space	A、B
	Ignored	$W \leq 0.01$	Ignored	-	
	$L \leq 40$	$W \leq 0.02$	10	-	
	$L \leq 20$	$W \leq 0.04$	10	-	
	Round (Dot Shape)				
	Average diameter (mm)	Maximum number	Minimum space		
	$D \leq 0.2$	Ignore	-		
	$D \leq 0.4$	10	-		
Dent	Serious one is not allowed				A
Wrinkles in polarizer	Serious one is not allowed				A
Bubbles on polarizer	Average diameter (mm)		Maximum number		A
	$D \leq 0.3$		Ignored		
	$0.3 < D \leq 0.5$		10		
	$0.5 < D \leq 1.0$		5		
1) Stains 2) Foreign Materials 3) Dark Spot	Filamentous (Line shape)				A、B
	Length (mm)	Width (mm)	Maximum number		
	Ignored	$W \leq 0.02$	Ignored		
	$L \leq 2.0$	$W \leq 0.03$	10		
	$L \leq 1.0$	$W \leq 0.06$	10		
	Round (Dot shape)				A、B
	Average diameter (mm)	Maximum number	Minimum Space		
	$D \leq 0.22$	Ignored	-		
	$0.22 < D \leq 0.33$	5	-		
	$0.33 < D$	0	-		
	In total	Filamentous + Round=10			
	Those wiped out easily are acceptable				
Dot-Defect (Note 1)			Type	Maximum number	A
	Bright dot-defect		1 dot	0	
	Dark dot-defect		1 dot	4	
			2 dots	1(sets)	
			In total	4	
In total				4	

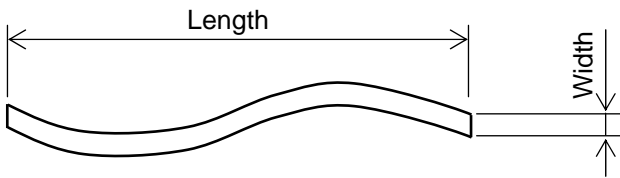
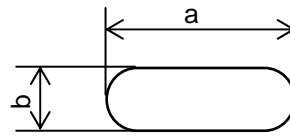

Fig 11.3



$$\text{Average diameter} = \frac{a+b}{2}$$

Fig 11.4

Note 1: The definitions of dot defect are as below:

- For bright dot-defect, showing black pattern, visible with 5% ND filter is defined.
- For dark dot-defect, showing white pattern, defect size over 1/2 dot area is defined.
- The definition of 1-dot-defect is the defect-dot, which is isolated and no adjacent defect-dot.
- The definition of adjacent dot is shown as Fig. 11.5.
- The Density of dot defect is defined in the area within diameter $\phi = 10\text{mm}$.

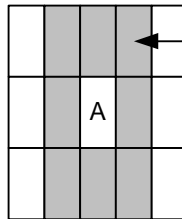

The dots colored gray are adjacent to defect-dot A.

Fig. 11.5

12. PRECAUTIONS

12.1 PRECAUTIONS of ESD

- 1) Before handling the display, please ensure your body has been connected to ground to avoid any damages by ESD. Also, do not touch display's interface directly when assembling.
- 2) Please remove the protection film very slowly before turning on the display to avoid generating ESD.

12.2 PRECAUTIONS of HANDLING

- 1) In order to keep the appearance of display in good condition; please do not rub any surfaces of the displays by sharp tools harder than 3H, especially touch panel, metal frame and polarizer.
- 2) Please do not pile the displays in order to avoid any scars leaving on the display. In order to avoid any injuries, please pay more attention for the edges of glasses and metal frame, and wear finger cots to protect yourself and the display before working on it.
- 3) Touching the display area or the terminal pins with bare hand is prohibited. This is because it will stain the display area and cause poor insulation between terminal pins, and might affect display's electrical characteristics furthermore.
- 4) Do not use any harmful chemicals such as acetone, toluene, and isopropyl alcohol to clean display's surfaces.
- 5) Please use soft cloth or absorbent cotton with ethanol to clean the display by gently wiping. Moreover, when wiping the display, please wipe it by horizontal or vertical direction instead of circling to prevent leaving scars on the display's surface, especially polarizer.
- 6) Please wipe any unknown liquids immediately such as saliva, water or dew on the display to avoid color fading or any permanently damages.
- 7) Maximum pressure to the surface of the display must be less than 1.96×10^4 Pa. If the area of adding pressure is less than 1 cm^2 , the maximum pressure must be less than 1.96N.

12.3 PRECAUTIONS of OPERATING

- 1) Please input signals and voltages to the displays according to the values defined in the section of electrical characteristics to obtain the best performance. Any voltages over than absolute maximum rating will cause permanent damages to this display. Also, any timing of the signals out of this specification would cause unexpected performance.
- 2) When the display is operating at significant low temperature, the response time will be slower than it at 25°C . In high temperature, the color will be slightly dark and blue compared to original pattern. However, these are temperature-related phenomenon of LCD and it will not cause permanent damages to the display when used within the operating temperature.
- 3) The use of screen saver or sleep mode is recommended when static images are likely for long periods of time. This is to avoid the possibility of image sticking.
- 4) Spike noise can cause malfunction of the circuit. The recommended limitation of spike noise is no bigger than $\pm 100 \text{ mV}$.

12.4 PRECAUTIONS of STORAGE

If the displays are going to be stored for years, please be aware the following notices.

- 1) Please store the displays in a dark room to avoid any damages from sunlight and other sources of UV light.
- 2) The recommended long-term storage temperature is between 10 C° ~35 C° and 55%~75% humidity to avoid causing bubbles between polarizer and LCD glasses, and polarizer peeling from LCD glasses.
- 3) It would be better to keep the displays in the container, which is shipped from KOE, and do not unpack it.
- 4) Please do not stick any labels on the display surface for a long time, especially on the polarizer.

12.5 PRECAUTIONS of IMAGE STICKING

- 1) Do not display the fixed image or very frequently repeated clips in a long period of time, it may cause image sticking on display. Even a video of several minutes, which is played in a loop, is considered as repetitive.
- 2) Screensaver or power saving mode is recommended to avoid image sticking effectively. Using moving images, scrolling text and alternating a fixed image with a moving image, are the ideal ways to reduce the possibility of image sticking.
- 3) Additionally, it is important to avoid using static bars at image boundaries. Typically, such bars are a result of difference in aspect ratio (e.g., playing 4:3 content on a 16:9 display).

13. DESIGNATION of LOT MARK

1) The lot mark is showing in Fig.13.1. First 4 digits are used to represent production lot, T represented made in Taiwan, and the last 6 digits are the serial number.

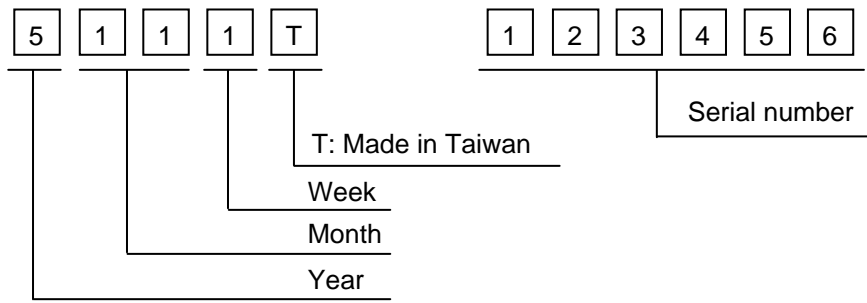

Fig. 13.1

2) The tables as below are showing what the first 4 digits of lot mark are shorted for.

Year	Lot Mark
2015	5
2016	6
2017	7
2018	8
2019	9

Month	Lot Mark	Month	Lot Mark
Jan.	01	Jul.	07
Feb.	02	Aug.	08
Mar.	03	Sep.	09
Apr.	04	Oct.	10
May	05	Nov.	11
Jun.	06	Dec.	12

Week	Lot Mark
1~7 days	1
8~14 days	2
15~21 days	3
22~28 days	4
29~31 days	5

3) Except letters I and O, revision number will be shown on lot mark and following letters A to Z.

4) The location of the lot mark is on the back of the display shown in Fig. 13.2.

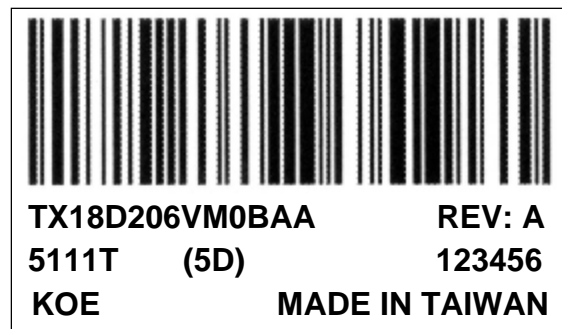

Fig. 13.2