

KOE

JDI Group

Kaohsiung Opto-Electronics Inc.

FOR MESSRS : _____

DATE : Mar. 02nd, 2018

CUSTOMER'S ACCEPTANCE SPECIFICATIONS

TX18D45VM5BAA

Contents

No.	ITEM	SHEET No.	PAGE
1	COVER	7B64PS 2701-TX18D45VM5BAA-2	1-1/1
2	RECORD OF REVISION	7B64PS 2702- TX18D45VM5BAA-2	2-1/1
3	GENERAL DATA	7B64PS 2703- TX18D45VM5BAA-2	3-1/1
4	ABSOLUTE MAXIMUM RATINGS	7B64PS 2704- TX18D45VM5BAA-2	4-1/1
5	ELECTRICAL CHARACTERISTICS	7B64PS 2705- TX18D45VM5BAA-2	5-1/1~2/2
6	OPTICAL CHARACTERISTICS	7B64PS 2706- TX18D45VM5BAA-2	6-1/2~2/2
7	BLOCK DIAGRAM	7B64PS 2707- TX18D45VM5BAA-2	7-1/1
8	RELIABILITY TESTS	7B64PS 2708- TX18D45VM5BAA-2	8-1/1
9	LCD INTERFACE	7B64PS 2709- TX18D45VM5BAA-2	9-1/7~7/7
10	OUTLINE DIMENSIONS	7B64PS 2710- TX18D45VM5BAA-2	10-1/2~2/2
11	APPEARANCE STANDARD	7B64PS 2711- TX18D45VM5BAA-2	11-1/3~3/3
12	PRECAUTIONS	7B64PS 2712- TX18D45VM5BAA-2	12-1/2~2/2
13	DESIGNATION OF LOT MARK	7B64PS 2713- TX18D45VM5BAA-2	13-1/1

ACCEPTED BY: _____

PROPOSED BY : *Oblack Tsai*

2. RECORD OF REVISION

DATE	SHEET No.	SUMMARY																																										
Mar.02,'18	7B64PS 2706 – TX18D45VM5BAA-2 Page 6-1/2	6. OPTICAL CHARACTERISTICS Revised : <table border="1" data-bbox="612 288 1490 425"> <thead> <tr> <th colspan="2">Item</th> <th>Symbol</th> <th>Min.</th> <th>Typ.</th> <th>Max.</th> </tr> </thead> <tbody> <tr> <td rowspan="3">Color Chromaticity</td> <td>Red</td> <td>Y</td> <td>0.30</td> <td>0.35</td> <td>0.40</td> </tr> <tr> <td rowspan="2">Green</td> <td>X</td> <td>0.31</td> <td>0.36</td> <td>0.41</td> </tr> <tr> <td>Y</td> <td>0.53</td> <td>0.58</td> <td>0.63</td> </tr> </tbody> </table> <p style="text-align: center;">↓</p> <table border="1" data-bbox="612 468 1490 604"> <thead> <tr> <th colspan="2">Item</th> <th>Symbol</th> <th>Min.</th> <th>Typ.</th> <th>Max.</th> </tr> </thead> <tbody> <tr> <td rowspan="3">Color Chromaticity</td> <td>Red</td> <td>Y</td> <td>0.28</td> <td>0.33</td> <td>0.38</td> </tr> <tr> <td rowspan="2">Green</td> <td>X</td> <td>0.28</td> <td>0.33</td> <td>0.38</td> </tr> <tr> <td>Y</td> <td>0.52</td> <td>0.57</td> <td>0.62</td> </tr> </tbody> </table>	Item		Symbol	Min.	Typ.	Max.	Color Chromaticity	Red	Y	0.30	0.35	0.40	Green	X	0.31	0.36	0.41	Y	0.53	0.58	0.63	Item		Symbol	Min.	Typ.	Max.	Color Chromaticity	Red	Y	0.28	0.33	0.38	Green	X	0.28	0.33	0.38	Y	0.52	0.57	0.62
	Item		Symbol	Min.	Typ.	Max.																																						
Color Chromaticity	Red	Y	0.30	0.35	0.40																																							
	Green	X	0.31	0.36	0.41																																							
		Y	0.53	0.58	0.63																																							
Item		Symbol	Min.	Typ.	Max.																																							
Color Chromaticity	Red	Y	0.28	0.33	0.38																																							
	Green	X	0.28	0.33	0.38																																							
		Y	0.52	0.57	0.62																																							
7B64PS 2713 – TX18D45VM5BAA-2 Page 13-1/1	13. DESIGNATION of LOT MARK Added : <table border="1" data-bbox="644 678 1458 806"> <thead> <tr> <th>REV.No</th> <th>ITEM</th> <th>REMARKS</th> </tr> </thead> <tbody> <tr> <td>A</td> <td>-</td> <td>-</td> </tr> <tr> <td>B</td> <td>LCD Color Filter Consolidation</td> <td>PCN 0991</td> </tr> </tbody> </table>	REV.No	ITEM	REMARKS	A	-	-	B	LCD Color Filter Consolidation	PCN 0991																																		
REV.No	ITEM	REMARKS																																										
A	-	-																																										
B	LCD Color Filter Consolidation	PCN 0991																																										

3. GENERAL DATA

3.1 DISPLAY FEATURES

This module is a 7" WVGA of 16:9 format amorphous silicon TFT. The pixel format is vertical stripe and sub pixels are arranged as R(red), G(green), B(blue) sequentially. This display is RoHS compliant, and COG (chip on glass) technology and LED backlight are applied on this display.

Part Name	TX18D45VM5BAA
Module Dimensions	165.0(W) mm x 106.0(H) mm x 8.0(D) mm
LCD Active Area	152.4(W) mm x 91.44(H) mm
Pixel Pitch	0.1905(W) mm x 0.1905(H) mm
Resolution	800 x 3(RGB)(W) x 480(H) Dots
Color Pixel Arrangement	R, G, B Vertical stripe
LCD Type	Transmissive Color TFT; Normally White
Display Type	Active Matrix
Number of Colors	262k Colors (6-bit RGB)
Backlight	Light Emitting Diode (LED)
Weight	128g
Interface	LVDS; 20 pins
Power Supply Voltage	3.3V for LCD; 9.0V for Backlight
Power Consumption	0.8W for LCD ; 1.62W for Backlight
Viewing Direction	Super Wide Version

4. ABSOLUTE MAXIMUM RATINGS

Item	Symbol	Min.	Max.	Unit	Remarks
Supply Voltage	V_{DD}	0	7.0	V	-
Input Voltage of Logic	V_I	-0.3	$V_{DD}+0.3$	V	Note 1
Operating Temperature	T_{OP}	-30	80	°C	Note 2
Storage Temperature	T_{st}	-30	80	°C	Note 2

Note 1: The rating is defined for the signal voltages of the interface such as CLK and pixel data pairs.

Note 2: The maximum rating is defined as above based on the chamber temperature, which might be different from ambient temperature after assembling the panel into the application. Moreover, some temperature-related phenomenon as below needed to be noticed:

- Background color, contrast and response time would be different in temperatures other than 25°C.
- Operating under high temperature will shorten LED lifetime.

5. ELECTRICAL CHARACTERISTICS

5.1 LCD CHARACTERISTICS

$T_a = 25\text{ }^\circ\text{C}$, $V_{SS} = 0\text{V}$

Item	Symbol	Condition	Min.	Typ.	Max.	Unit	Remarks
Power Supply Voltage	V_{DD}	-	3.0	3.3	3.6	V	-
Input Voltage of Logic	V_I	V_{IH}	-	-	+100	mV	Note 1
		V_{IL}	-100	-	-		
Power Supply Current	I_{DD}	-	-	240	-	mA	Note 2,3
Frame Frequency	f_{Frame}	-	-	60	66	Hz	-
DCLK Frequency	f_{CLK}	-	29	32.32	36.15	MHz	-

Note 1: VCM1.2V is common mode voltage of LVDS transmitter and receiver. The input terminal of LVDS receiver is transmitter with 100Ω .

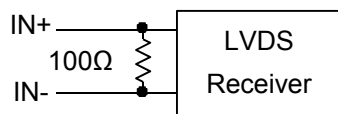

Note 2: An all black check pattern is used when measuring I_{DD} , f_{Frame} is set to 60Hz.

Note 3: 1.0A fuse is applied in the module for I_{DD} . For display activation and protection purpose, power supply is recommended larger than 2.5A to start the display and break fuse once any short circuit occurred.

5.2 BACKLIGHT CHARACTERISTICS

$T_a = 25\text{ }^\circ\text{C}$

Item	Symbol	Condition	Min.	Typ.	Max.	Unit	Remarks
LED Input Voltage	V_{LED}	Backlight Unit	8.4	9.0	10.2	V	Note1
LED Forward Current	I_{LED}	Backlight Unit	-	180	-	mA	
LED Lifetime	-	$I_{LED}=180\text{ mA}$	-	40K	-	hrs	Note 2

Note 1: Fig. 5.1 shows the LED backlight circuit. V_{LED} and I_{LED} is many-to-one relationship, the above V_{LED} range is defined to obtain 180mA and the R is 0Ω .

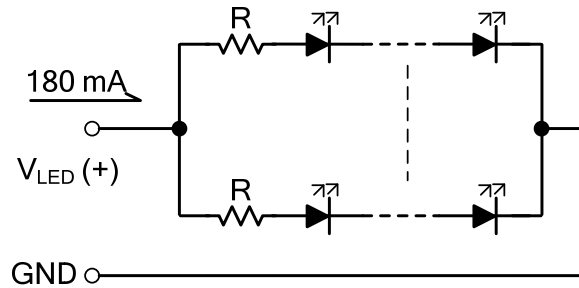

Fig. 5.1

Note 2: The estimated lifetime is specified as the time to reduce 50% brightness by applying 180 mA at $25\text{ }^\circ\text{C}$

6. OPTICAL CHARACTERISTICS

The optical characteristics are measured based on the conditions as below:

- Supplying the signals and voltages defined in the section of electrical characteristics.
- The backlight unit needs to be turned on for 30 minutes.
- The ambient temperature is 25 °C.
- In the dark room less than 100 lx, the equipment has been set for the measurements as shown in Fig 6.1.

$$T_a = 25\text{ }^\circ\text{C}, f_{Frame} = 60\text{ Hz}, V_{DD} = 3.3\text{ V}$$

Item	Symbol	Condition	Min.	Typ.	Max.	Unit	Remarks	
Brightness of White	-	$\phi = 0^\circ, \theta = 0^\circ,$ $I_{LED} = 180\text{ mA}$	480	600	-	cd/m ²	Note 1	
Brightness Uniformity	-		70	-	-	%	Note 2	
Contrast Ratio	CR		200	400	-	-	Note 3	
Response Time	Tr + Tf	$\phi = 0^\circ, \theta = 0^\circ$	-	20	-	ms	Note 4	
NTSC Ratio	-	$\phi = 0^\circ, \theta = 0^\circ$	-	45	-	%	-	
Viewing Angle	θ_x	$\phi = 0^\circ, CR \geq 10$	-	80	-	Degree	Note 5	
	$\theta_{x'}$	$\phi = 180^\circ, CR \geq 10$	-	80	-			
	θ_y	$\phi = 90^\circ, CR \geq 10$	-	80	-			
	$\theta_{y'}$	$\phi = 270^\circ, CR \geq 10$	-	80	-			
Color Chromaticity	Red	X	$\phi = 0^\circ, \theta = 0^\circ$	0.52	0.57	0.62	-	Note 6
		Y		0.28	0.33	0.38		
	Green	X		0.28	0.33	0.38		
		Y		0.52	0.57	0.62		
	Blue	X		0.10	0.15	0.20		
		Y		0.07	0.12	0.17		
	White	X		0.25	0.30	0.35		
		Y		0.27	0.32	0.37		

Note 1: The brightness is measured from the center point of the panel, P5 in Fig. 6.2, for the typical value.

Note 2: The brightness uniformity is calculated by the equation as below:

$$\text{Brightness uniformity} = \frac{\text{Min. Brightness}}{\text{Max. Brightness}} \times 100\%$$

which is based on the brightness values of the 9 points in active area measured by BM-5 as shown in Fig. 6.2.

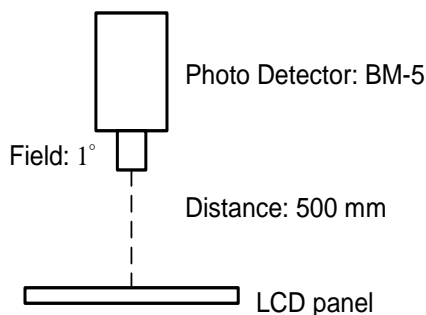

Fig 6.1

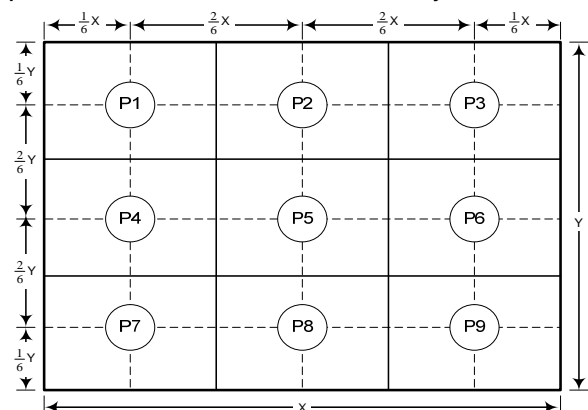

Fig 6.2

Note 3: The Contrast ratio is measured from the center point of the panel, P5, and defined as the following equation:

$$CR = \frac{\text{Brightness of White}}{\text{Brightness of Black}}$$

Note 4: The definition of response time is shown in Fig. 6.3. The rising time is the period from 90% brightness to 10% brightness when the data is from white to black. Oppositely, Falling time is the period from 10% brightness rising to 90% brightness.

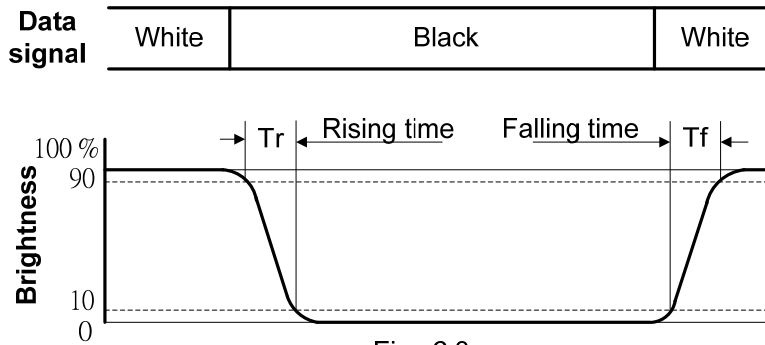

Fig . 6.3

Note 5: The definition of viewing angle is shown in Fig. 6.4. Angle ϕ is used to represent viewing directions, for instance, $\phi = 270^\circ$ means 6 o'clock, and $\phi = 0^\circ$ means 3 o'clock. Moreover, angle θ is used to represent viewing angles from axis Z toward plane XY.

The display is super wide viewing angle version, so that the best optical performance can be obtained from every viewing direction.

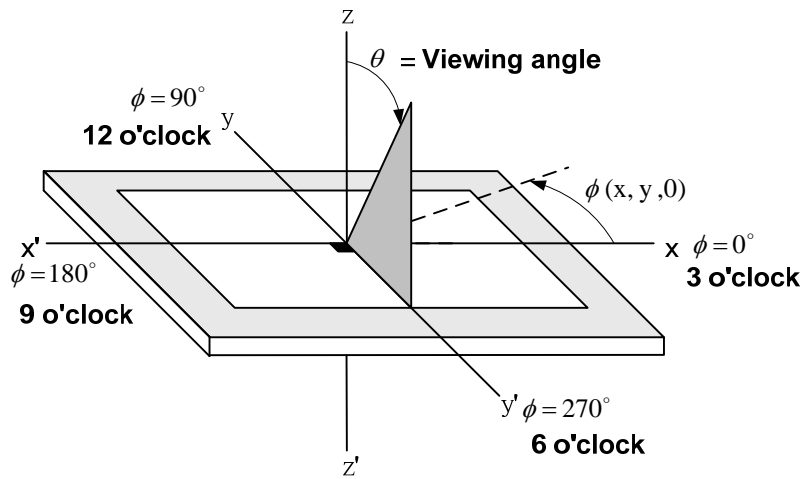
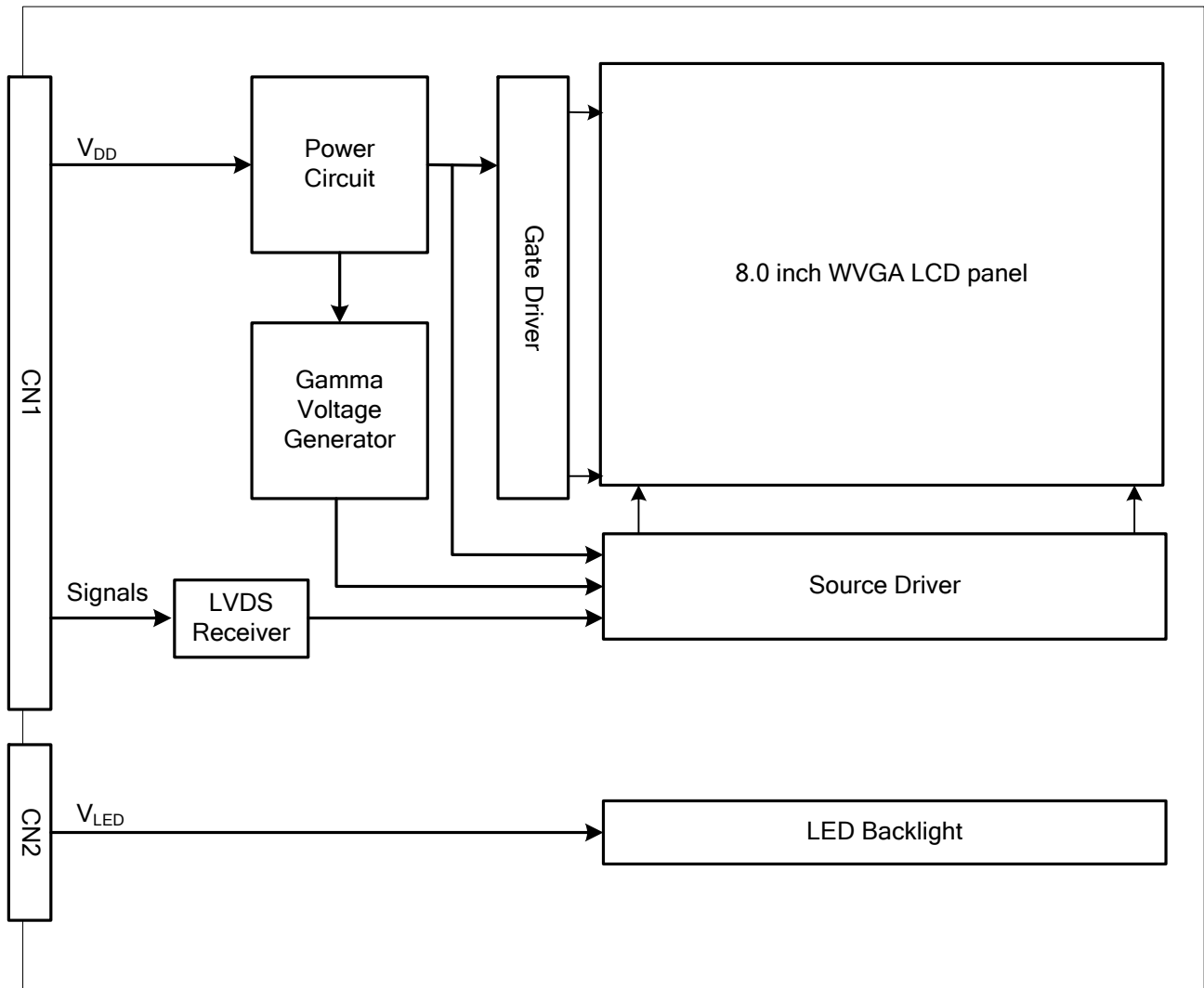

Fig. 6.4

Note 6: The color chromaticity is measured from the center point of the panel, P5, as shown in Fig. 6.2.

7. BLOCK DIAGRAM



Note : Signals are CLK and pixel data pairs.

8. RELIABILITY TESTS

Test Item	Condition	
High Temperature	1) Operating 2) 80 °C	240 hrs
Low Temperature	1) Operating 2) -30 °C	240 hrs
High Temperature	3) 1) Storage 4) 2) 80 °C	240 hrs
Low Temperature	5) 1) Storage 6) 2) -30 °C	240 hrs
Heat Cycle	1) Operating 2) -20 °C ~70 °C 3) 3hrs~1hr~3hrs	240 hrs
Thermal Shock	1) Non-Operating 2) -35 °C ↔85 °C 3) 0.5 hr ↔0.5 hr	240 hrs
High Temperature & Humidity	1) Operating 2) 40 °C & 85%RH 3) Without condensation	240 hrs (Note 3)
Vibration	1) Non-Operating 2) 20~200 Hz 3) 2G 4) X, Y, and Z directions	1 hr for each direction
Mechanical Shock	1) Non-Operating 2) 10 ms 3) 50G 4) ±X, ±Y and ±Z directions	Once for each direction
ESD	1) Operating 2) Tip: 150 pF, 330 Ω 3) Air discharge for glass: ± 8KV 4) Contact discharge for metal frame: ± 8KV	1) Glass: 9 points 2) Metal frame: 8 points (Note 4)

Note 1: Display functionalities are inspected under the conditions defined in the specification after the reliability tests.

Note 2: The display is not guaranteed for use in corrosive gas environments.

Note 3: Under the condition of high temperature & humidity, if the temperature is higher than 40 °C , the humidity needs to be reduced as Fig. 8.1 shown.

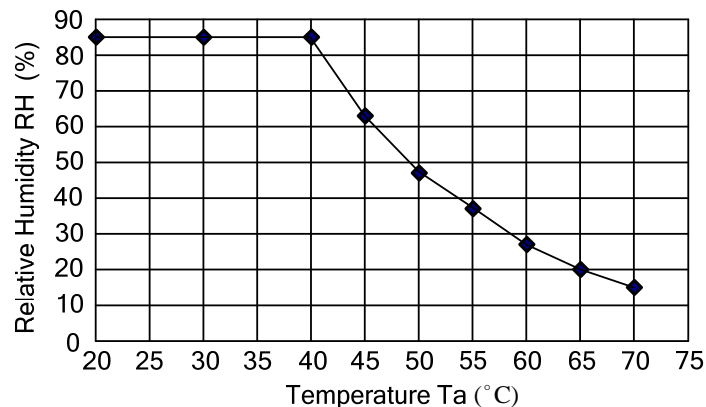

Fig. 8.1

Note 4: All pins of LCD interface (CN1) have been tested by ± 100V contact discharge of ESD under non-operating condition.

9. LCD INTERFACE

9.1 INTERFACE PIN CONNECTIONS

The display interface connector is FI-SEB20P-HF13E made by JAE and more details of the connector are shown in the section of outline dimension.

Pin assignment of LCD interface is as below:

Pin No.	Signal	Signal	Pin No.	Signal	Signal
1	V _{DD}	Power Supply for Logic	11	IN2-	B2~B5, DE
2	LR	H: Left to right (Default); L: Right to Left	12	IN2+	
3	UD	L: Up to down (Default); H: Down to up	13	V _{SS}	Ground
4	V _{SS}	Ground	14	CLK IN-	Pixel Clock
5	IN0-	R0~R5, G0	15	CLK IN+	
6	IN0+		16	V _{SS}	Ground
7	V _{SS}	Ground	17	NC	No Connection
8	IN1-	G1~G5, B0~B1	18	NC	No Connection
9	IN1+		19	NC	No Connection
10	V _{SS}	Ground	20	NC	No Connection

Note 1: Please refer to 9.8 SCAN DIRECTION for the setting methods of UD, LR function.

The backlight interface connector is BHR-03VS-1 made by JST, and pin assignment of backlight is as below:

Pin No.	Signal	Level	Function
1	V _{LED+}	-	Power Supply for LED
2	NC	-	No connection
3	V _{LED-}	-	GND

9.2 LVDS INTERFACE

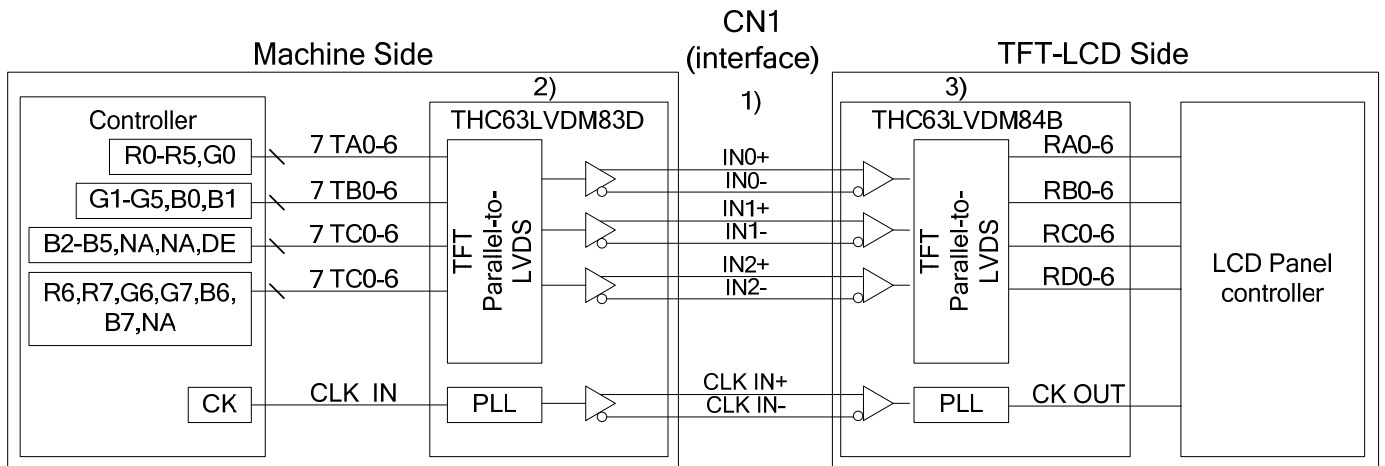

Note 1: LVDS cable impedance should be 100 ohms per signal line when each 2-lines (+,-) is used in differential mode.

Note 2: The recommended transmitter, THC63LVDM83R, is made by Thine or equivalent, which is not contained in the module.

Note 3: The receiver built-in the module is THC63LVDM84B made by Thine.

9.3 LVDS DATA FORMAT

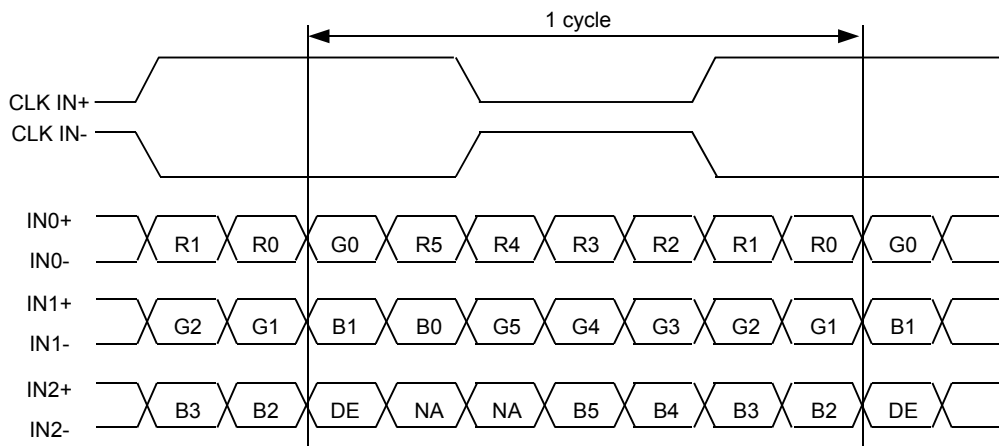

DE: Display Enable

NA: Not Available

9.4 TIMING CHART

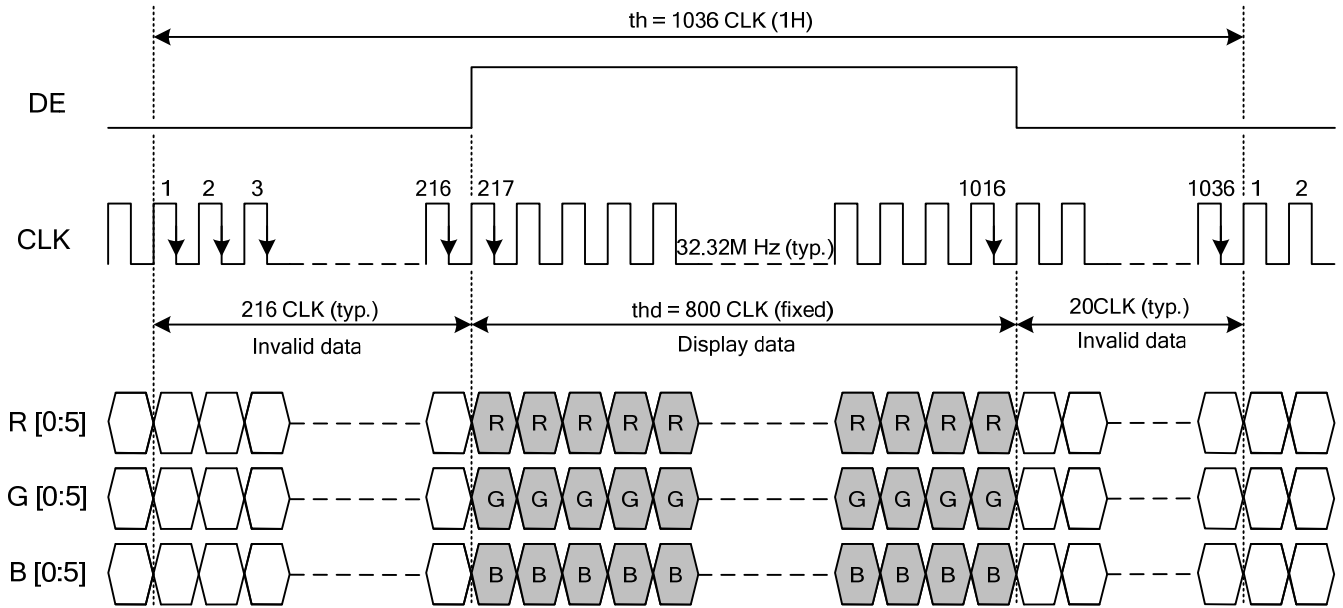

Fig. 9.1 Horizontal Timing

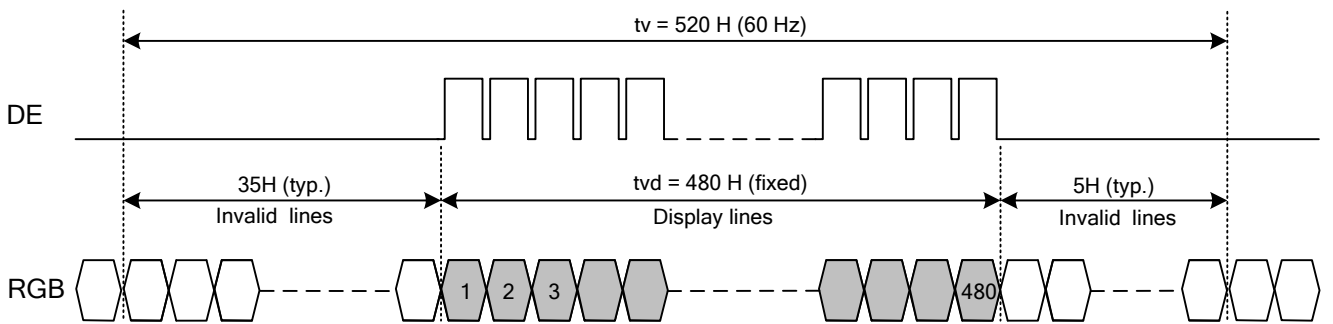

Fig.9.2 Vertical Timing

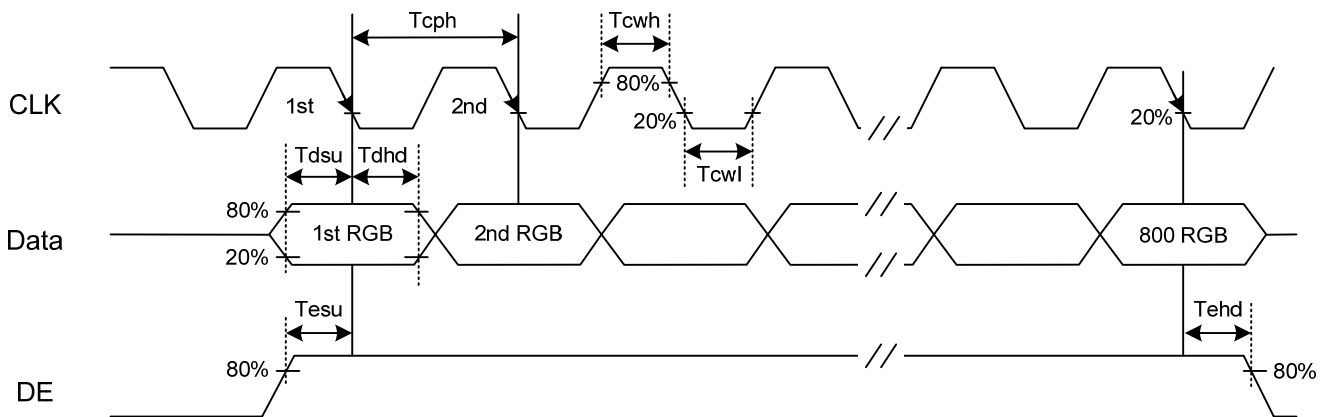

Fig. 9.3 Setup & Hold Time

9.5 TIMING TABLE

The column of timing sets including minimum, typical, and maximum as below are based on the best optical performance, frame frequency (Vsync) = 60 Hz to define. If 60 Hz is not the aim to set, less than 66 Hz for Vsync is recommended to apply for better performance by other parameter combination as the definitions in section 5.1.

A. Horizontal and Vertical Timing

	Item	Symbol	Min.	Typ.	Max.	Unit
Horizontal	CLK Frequency	fclk	29.0	32.32	36.15	MHz
	Display Data	thd	800			CLK
	Cycle Time	th	1020	1036	1057	
Vertical	Display Data	tvd	480			H
	Cycle Time	tv	517	520	526	

B. Setup and Hold Time

	Item	Symbol	Min.	Typ.	Max.	Unit
CLK	Duty	Tcwh	40	50	60	%
	Cycle Time	Tcph	-	30.94	-	ns
Data	Setup Time	Tdsu	6	-	-	
	Hold Time	Tdhd	6	-	-	
DE	Setup Time	Tesu	6	-	-	
	Hold Time	Tehd	6	-	-	

9.6 LVDS RECEIVER TIMING

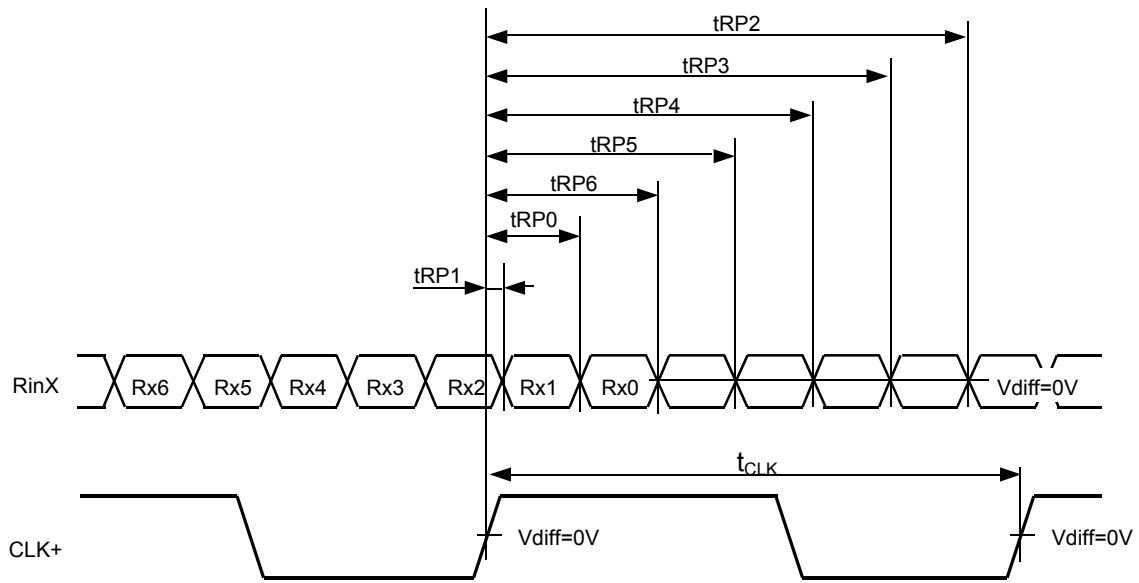

$$RinX = (RinX+) - (RinX-) \quad (X=0, 1, 2)$$

	Item	Symbol	Min.	Typ.	Max.	Unit
CLK	Cycle frequency	$1/t_{CLK}$	29.0	32.32	36.15	MHz
RinX (X=0,1,2)	0 data position	t_{RP0}	$1/7 * t_{CLK} - 0.49$	$1/7 * t_{CLK}$	$1/7 * t_{CLK} + 0.49$	ns
	1st data position	t_{RP1}	-0.49	0	+0.49	
	2nd data position	t_{RP2}	$6/7 * t_{CLK} - 0.49$	$6/7 * t_{CLK}$	$6/7 * t_{CLK} + 0.49$	
	3rd data position	t_{RP3}	$5/7 * t_{CLK} - 0.49$	$5/7 * t_{CLK}$	$5/7 * t_{CLK} + 0.49$	
	4th data position	t_{RP4}	$4/7 * t_{CLK} - 0.49$	$4/7 * t_{CLK}$	$4/7 * t_{CLK} + 0.49$	
	5th data position	t_{RP5}	$3/7 * t_{CLK} - 0.49$	$3/7 * t_{CLK}$	$3/7 * t_{CLK} + 0.49$	
	6th data position	t_{RP6}	$2/7 * t_{CLK} - 0.49$	$2/7 * t_{CLK}$	$2/7 * t_{CLK} + 0.49$	

9.7 POWER SEQUENCE

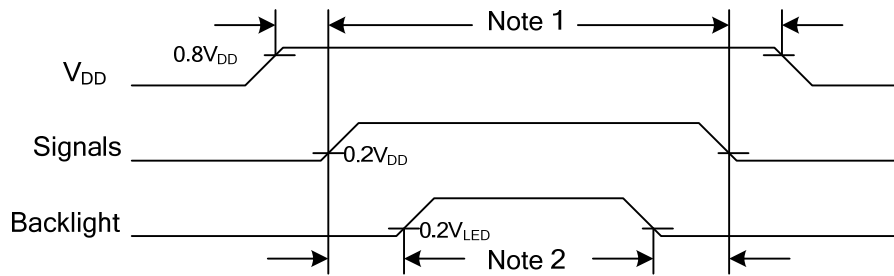

Note 1: In order to avoid any damages, V_{DD} has to be applied before all other signals. The opposite is true for power off where V_{DD} has to be remained on until all other signals have been switch off. The recommended time period is 1 second.

Note 2: In order to avoid showing uncompleted patterns in transient state. It is recommended that switching the backlight on is delayed for 1 second after the signals have been applied. The opposite is true for power off where the backlight has to be switched off 1 second before the signals are removed.

9.8 SCAN DIRECTION

Scan direction is available to be switched as below by setting CN1's UD & LR pin.

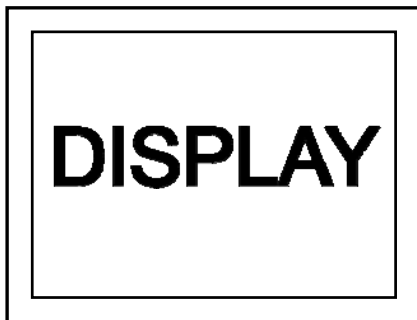

UD : L or Open ; LR : H or Open (Default)



UD : L or Open ; LR : L



UD : H ; LR : H or Open



UD : H ; LR : L

9.9 DATA INPUT for DISPLAY COLOR

Input color		Red Data						Green Data						Blue Data					
		R5	R4	R3	R2	R1	R0	G5	G4	G3	G2	G1	G0	B5	B4	B3	B2	B1	B0
		MSB			LSB			MSB			LSB			MSB			LSB		
Basic Color	Black	0	0	0	0	0	0	0	0	0	0	0	0	0	0	0	0	0	0
	Red(63)	1	1	1	1	1	1	0	0	0	0	0	0	0	0	0	0	0	0
	Green(63)	0	0	0	0	0	0	1	1	1	1	1	1	0	0	0	0	0	0
	Blue(63)	0	0	0	0	0	0	0	0	0	0	0	0	1	1	1	1	1	1
	Cyan	0	0	0	0	0	0	1	1	1	1	1	1	1	1	1	1	1	1
	Magenta	1	1	1	1	1	1	0	0	0	0	0	0	1	1	1	1	1	1
	Yellow	1	1	1	1	1	1	1	1	1	1	1	1	0	0	0	0	0	0
	White	1	1	1	1	1	1	1	1	1	1	1	1	1	1	1	1	1	1
Red	Black	0	0	0	0	0	0	0	0	0	0	0	0	0	0	0	0	0	0
	Red (1)	0	0	0	0	0	1	0	0	0	0	0	0	0	0	0	0	0	0
	Red (2)	0	0	0	0	1	0	0	0	0	0	0	0	0	0	0	0	0	0
	:	:	:	:	:	:	:	:	:	:	:	:	:	:	:	:	:	:	:
	:	:	:	:	:	:	:	:	:	:	:	:	:	:	:	:	:	:	:
	Red (62)	1	1	1	1	1	0	0	0	0	0	0	0	0	0	0	0	0	0
	Red (63)	1	1	1	1	1	1	0	0	0	0	0	0	0	0	0	0	0	0
Green	Black	0	0	0	0	0	0	0	0	0	0	0	0	0	0	0	0	0	0
	Green (1)	0	0	0	0	0	0	0	0	0	0	0	1	0	0	0	0	0	0
	Green (2)	0	0	0	0	0	0	0	0	0	0	1	0	0	0	0	0	0	0
	:	:	:	:	:	:	:	:	:	:	:	:	:	:	:	:	:	:	:
	:	:	:	:	:	:	:	:	:	:	:	:	:	:	:	:	:	:	:
	Green (62)	0	0	0	0	0	0	1	1	1	1	1	0	0	0	0	0	0	0
	Green (63)	0	0	0	0	0	0	1	1	1	1	1	1	0	0	0	0	0	0
Blue	Black	0	0	0	0	0	0	0	0	0	0	0	0	0	0	0	0	0	0
	Blue (1)	0	0	0	0	0	0	0	0	0	0	0	0	0	0	0	0	0	1
	Blue (2)	0	0	0	0	0	0	0	0	0	0	0	0	0	0	0	0	1	0
	:	:	:	:	:	:	:	:	:	:	:	:	:	:	:	:	:	:	:
	:	:	:	:	:	:	:	:	:	:	:	:	:	:	:	:	:	:	:
	Blue (62)	0	0	0	0	0	0	0	0	0	0	0	0	1	1	1	1	1	0
	Blue (63)	0	0	0	0	0	0	0	0	0	0	0	0	1	1	1	1	1	1

10. OUTLINE DIMENSIONS

10.1 FRONT VIEW

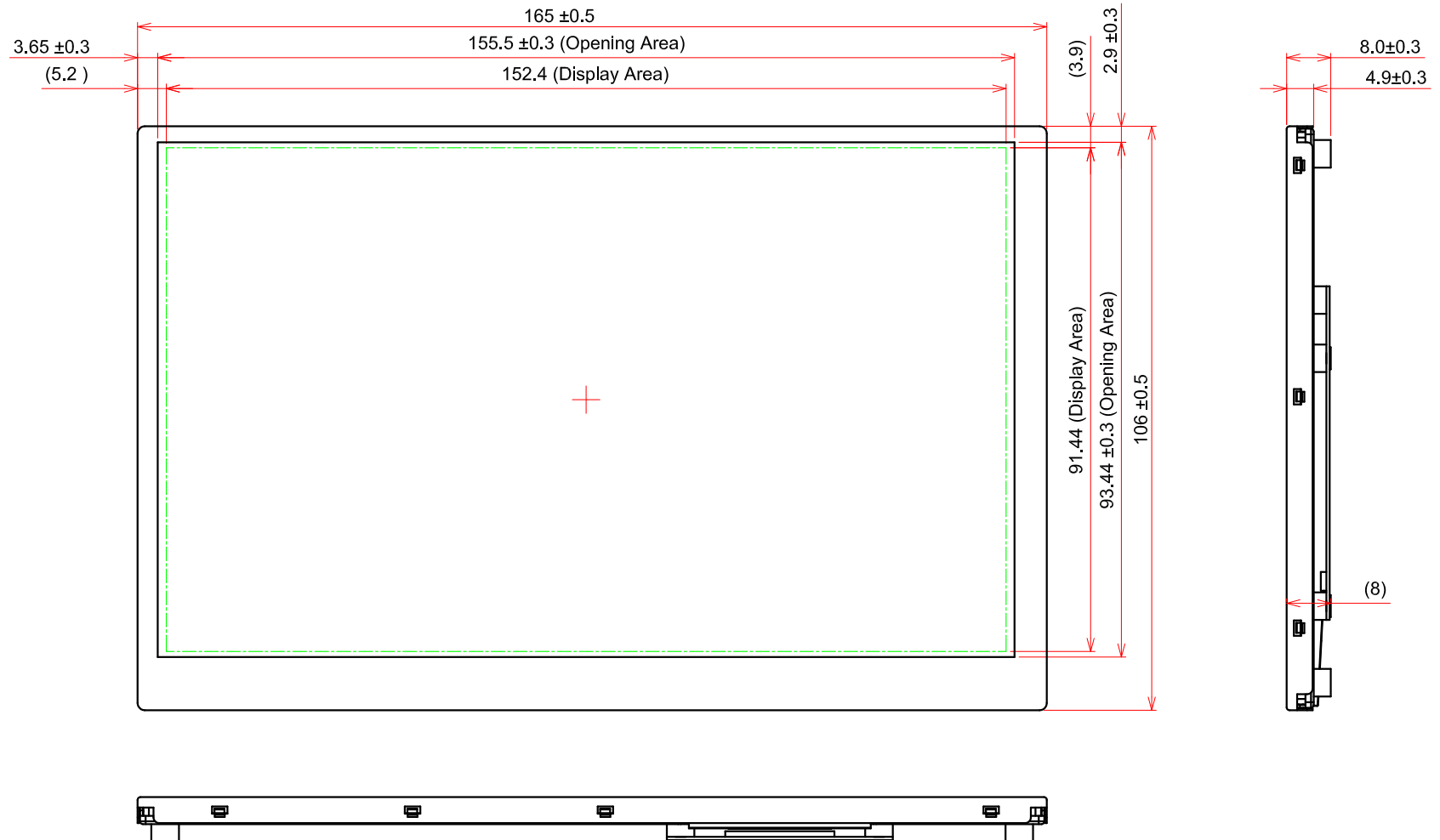

General Tolerance: ± 0.5 mm
 Scale : NTS
 Unit : mm

10.2 REAR VIEW

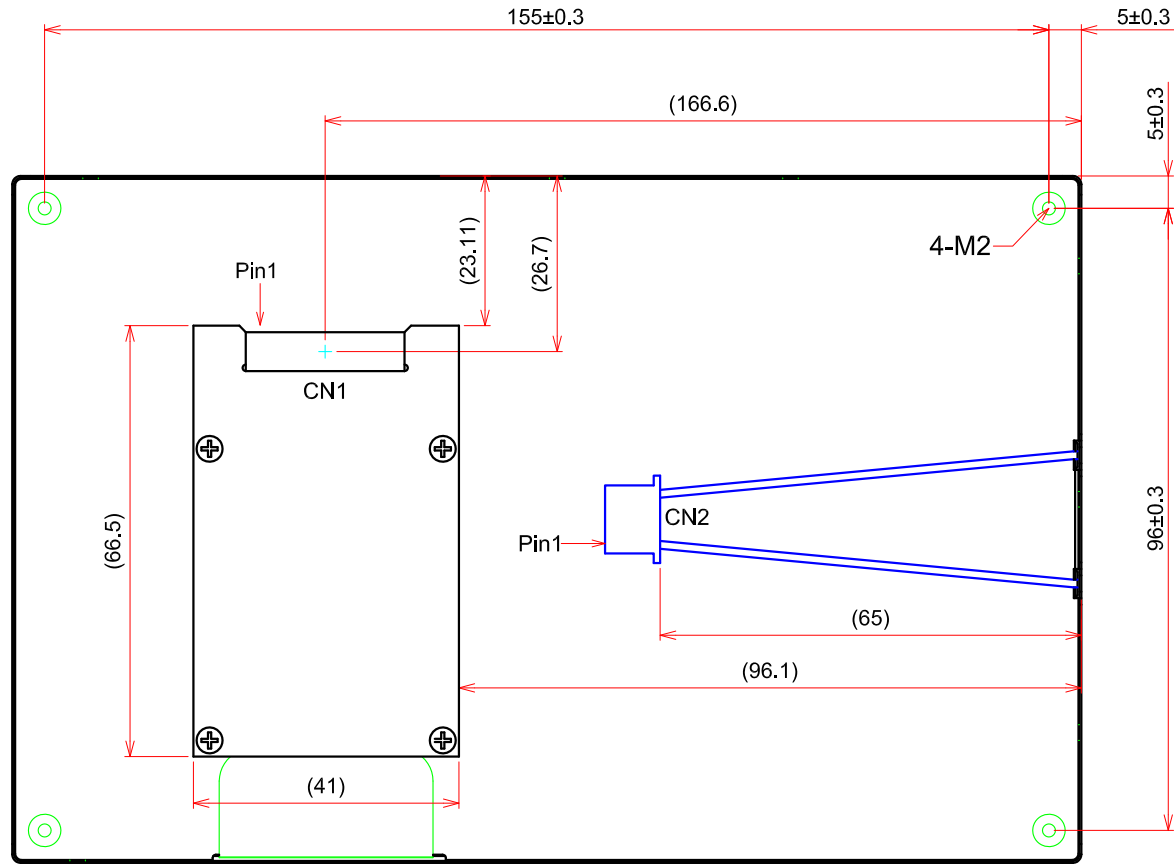

General Tolerance: ± 0.5 mm
 Scale : NTS
 Unit : mm

11. APPEARANCE STANDARD

The appearance inspection is performed in a room around 500~1000 lx based on the conditions as below:

- The distance between inspector's eyes and display is 30 cm.
- The viewing zone is defined with angle θ shown in Fig.11.1 The inspection should be performed within 45° when display is shut down. The inspection should be performed within 5° when display is power on.

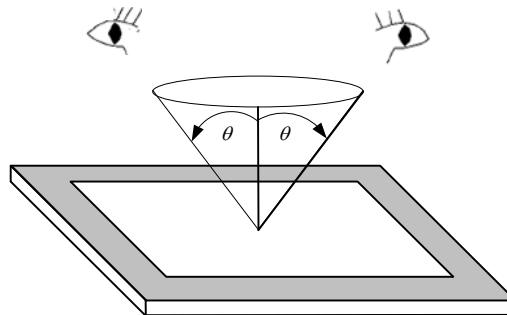

Fig. 11.1

11.1 THE DEFINITION OF LCD ZONE

LCD panel is divided into 2 areas as shown in Fig.11.2 for appearance specification in next section. A zone is the LCD active area (dot area); B zone is the area, between A zone and metal frame.

In terms of housing design, B zone is the recommended window area customers' housing should be located in.

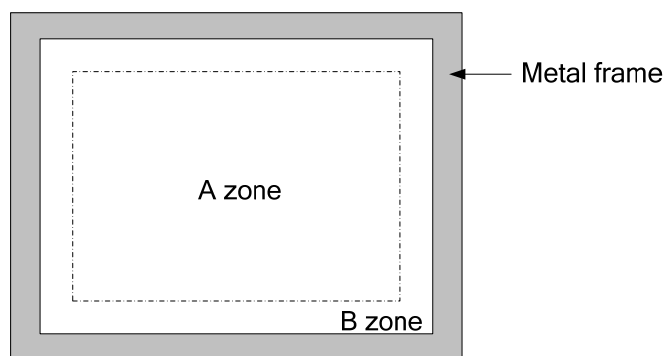

Fig. 11.2

11.2 LCD APPEARANCE SPECIFICATION

The specification as below is defined as the amount of unexpected phenomenon or material in different zones of LCD panel. The definitions of length, width and average diameter using in the table are shown in Fig. 11.3 and Fig. 11.4.

Item	Criteria				Applied zone	
Scratches	Length (mm)	Width (mm)	Maximum number	Minimum space	A · B	
	Ignored	$W \leq 0.01$	Ignored	-		
	$L \leq 40$	$W \leq 0.02$	10	-		
	$L \leq 20$	$W \leq 0.04$	10	-		
	Round (Dot Shape)					
	Average diameter (mm)	Maximum number	Minimum space			
	$D \leq 0.2$	Ignore	-			
	$D \leq 0.4$	10	-			
Dent	Serious one is not allowed				A	
Wrinkles in polarizer	Serious one is not allowed				A	
Bubbles on polarizer	Average diameter (mm)		Maximum number		A	
	$D \leq 0.3$		Ignored			
	$D \leq 0.5$		10			
	$D \leq 1.0$		5			
1) Stains 2) Foreign Materials 3) Dark Spot	Filamentous (Line shape)				A · B	
	Length (mm)	Width (mm)	Maximum number			
	Ignored	$W \leq 0.02$	Ignored			
	$L \leq 2.0$	$W \leq 0.03$	10			
	$L \leq 1.0$	$W \leq 0.06$	10			
	Round (Dot shape)				A · B	
	Average diameter (mm)	Maximum number	Minimum Space			
	$D \leq 0.22$	Ignored	-			
	$D \leq 0.33$	5	-			
	$D > 0.33$	0	-			
	In total	Filamentous + Round=10				
	Those wiped out easily are acceptable					
	Dot-Defect (Note 1)	Type		Maximum number		A
Bright dot-defect		1 dot		4		
		2 adjacent dot		1		
		3 adjacent dot or above		Not allowed		
		Density		$2/\phi 20\text{mm}$		
		In total		5		
Dark dot-defect		1 dot		5		
		2 adjacent dot		2		
		3 adjacent dot or above		Not allowed		
		Density		$3/\phi 20\text{mm}$		
		In total		5		
In total		10				

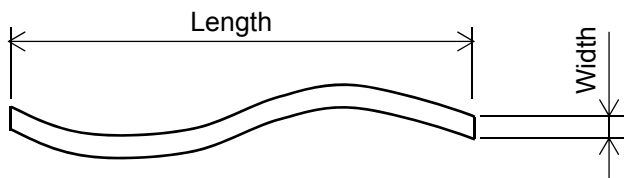

Fig 11.3

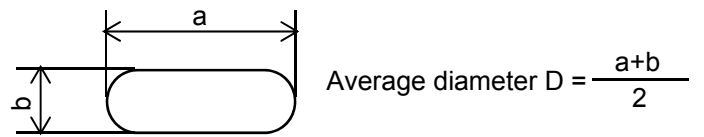

Fig 11.4

Note 1: The definitions of dot defect are as below:

- The defect area of the dot must be bigger than half of a dot.
- For bright dot-defect, showing black pattern, the dot's brightness must be over 30% brighter than others.
- For dark dot-defect, showing white pattern, the dot's brightness must be under 70% darker than others.
- The definition of 1-dot-defect is the defect-dot, which is isolated and no adjacent defect-dot.
- The definition of adjacent dot is shown as Fig. 11.5.
- The Density of dot defect is defined in the area within diameter $\phi = 20\text{mm}$.

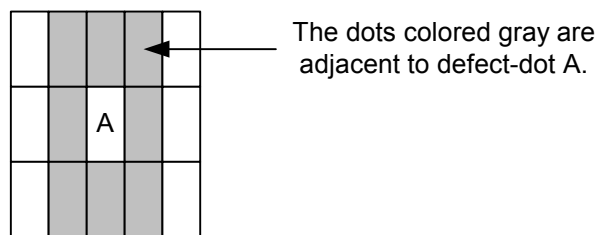

Fig. 11.5

12. PRECAUTIONS

12.1 PRECAUTIONS of ESD

- 1) Before handling the display, please ensure your body has been connected to ground to avoid any damages by ESD. Also, do not touch display's interface directly when assembling.
- 2) Please remove the protection film very slowly before turning on the display to avoid generating ESD.

12.2 PRECAUTIONS of HANDLING

- 1) In order to keep the appearance of display in good condition, please do not rub any surfaces of the displays by sharp tools harder than 3H, especially touch panel, metal frame and polarizer.
- 2) Please do not stack the displays as this may damage the surface. In order to avoid any injuries, please avoid touching the edge of the glass or metal frame and wore gloves during handling.
- 3) Touching the polarizer or terminal pins with bare hand should be avoided to prevent staining and poor electrical contact.
- 4) Do not use any harmful chemicals such as acetone, toluene, and isopropyl alcohol to clean display's surfaces.
- 5) Please use soft cloth or absorbent cotton with ethanol to clean the display by gently wiping. Moreover, when wiping the display, please wipe it by horizontal or vertical direction instead of circling to prevent leaving scars on the display's surface, especially polarizer.
- 6) Please wipe any unknown liquids immediately such as saliva, water or dew on the display to avoid color fading or any permanently damages.
- 7) Maximum pressure to the surface of the display must be less than 1.96×10^4 Pa. If the area of adding pressure is less than 1 cm^2 , the maximum pressure must be less than 1.96N.

12.3 PRECAUTIONS OF OPERATING

- 1) Please input signals and voltages to the displays according to the values defined in the section of electrical characteristics to obtain the best performance. Any voltages over than absolute maximum rating will cause permanent damages to this display. Also, any timing of the signals out of this specification would cause unexpected performance.
- 2) When the display is operating at significant low temperature, the response time will be slower than it at 25°C . In high temperature, the color will be slightly dark and blue compared to original pattern. However, these are temperature-related phenomenon of LCD and it will not cause permanent damages to the display when used within the operating temperature.
- 3) The use of screen saver or sleep mode is recommended when static images are likely for long periods of time. This is to avoid the possibility of image sticking.
- 4) Spike noise can cause malfunction of the circuit. The recommended limitation of spike noise is no bigger than $\pm 100 \text{ mV}$.

12.4 PRECAUTIONS of STORAGE

If the displays are going to be stored for years, please be aware the following notices.

- 1) Please store the displays in a dark room to avoid any damages from sunlight and other sources of UV light.
- 2) The recommended long term storage temperature is between 10 C° ~35 C° and 55%~75% humidity to avoid causing bubbles between polarizer and LCD glasses, and polarizer peeling from LCD glasses.
- 3) It would be better to keep the displays in the container, which is shipped from KOE, and do not unpack it.
- 4) Please do not stick any labels on the display surface for a long time, especially on the polarizer.

13. DESIGNATION of LOT MARK

1) The lot mark is showing in Fig.13.1. First 4 digits are used to represent production lot, T represented made in Taiwan, and the last 6 digits are the serial number.

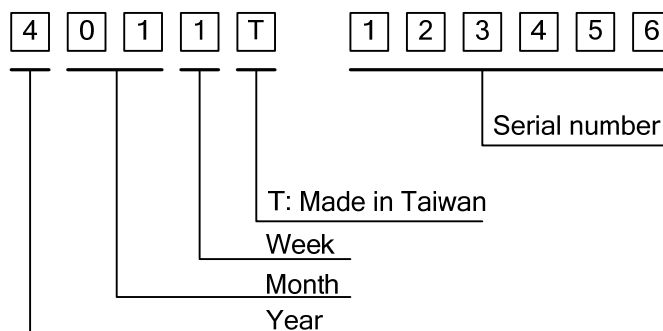

Fig. 13.1

2) The tables as below are showing what the first 4 digits of lot mark are shorted for.

Year	Lot Mark
2014	4
2015	5
2016	6
2017	7
2018	8

Month	Lot Mark	Month	Lot Mark
Jan.	01	Jul.	07
Feb.	02	Aug.	08
Mar.	03	Sep.	09
Apr.	04	Oct.	10
May	05	Nov.	11
Jun.	06	Dec.	12

Week	Lot Mark
1~7 days	1
8~14 days	2
15~21 days	3
22~28 days	4
29~31 days	5

3) Except letters I and O, revision number will be shown on lot mark and following letters A to Z.

REV.No	ITEM	REMARKS
A	-	-
B	LCD Color Filter Consolidation	PCN 0991

4) The location of the lot mark is on the back of the display shown in Fig. 13.2.

Label example:

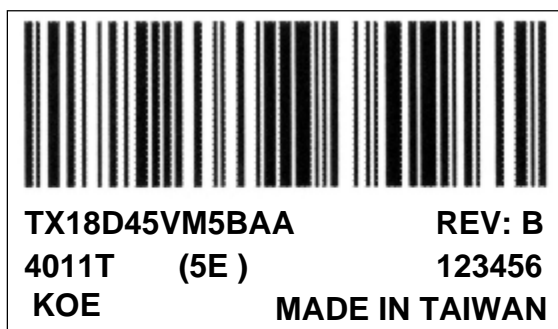

Fig. 13.2