

KOE

JDI Group

TENTATIVE

Kaohsiung Opto-Electronics Inc.

FOR MESSRS : _____

DATE : Mar. 29th, 2019

TECHNICAL DATA

TX20D207VM0AAA

Contents

No.	ITEM	SHEET No.	PAGE
1	COVER	7B64LTD-2604-2	1-1/1
2	RECORD OF REVISION	7B64LTD-2604-2	2-1/1
3	GENERAL DATA	7B64LTD-2604-2	3-1/1
4	ABSOLUTE MAXIMUM RATINGS	7B64LTD-2604-2	4-1/1
5	ELECTRICAL CHARACTERISTICS	7B64LTD-2604-2	5-1/2~2/2
6	OPTICAL CHARACTERISTICS	7B64LTD-2604-2	6-1/2~2/2
7	BLOCK DIAGRAM	7B64LTD-2604-2	7-1/1
8	LCD INTERFACE	7B64LTD-2604-2	8-1/6~6/6
9	OUTLINE DIMENSIONS	7B64LTD-2604-2	9-1/2~2/2
10	DESIGNATION OF LOT MARK	7B64LTD-2604-2	10-1/1

ACCEPTED BY: _____

PROPOSED BY: John Chou

2. RECORD OF REVISION

DATE	SHEET No.	SUMMARY
Mar.29,'19	7B64LTD-2604-2 PAGE 8-1/6	8.1 INTERFACE PIN CONNECTIONS Revised : Pin No.4 UD/LR Low :Normal, High :Reverse ↓ High :Normal, Low :Reverse
	7B64LTD-2604-2 PAGE 8-3/6	8.5 DISPLAY MODE CONTROL Revised : UD/LR : Low ; UD/LR : High ↓ UD/LR : High ; UD/LR : Low

3. GENERAL DATA

3.1 DISPLAY FEATURES

This module is a 8.0" WXGA of 16:9 format LTPS TFT. The pixel format is vertical stripe and sub pixels are arranged as R(red), G(green), B(blue) sequentially. This display is RoHS compliant, and COG (chip on glass) technology and LED backlight are applied on this display.

Part Name	TX20D207VM0AAA
Module Dimensions	189.5 (W) mm × 119.4 (H) mm × 11.6 (D) mm (Typ.)
LCD Active Area	173.952 (W)mm x 104.3712(H)mm
Pixel Pitch	0.1359 (W) mm × 0.1359 (H) mm
Resolution	1280× 3 (RGB) (W) × 768 (H) dots
Color Pixel Arrangement	RGB Vertical Stripe
LCD Type	Transmissive Type, Normally Black
Display Type	Active Matrix
Number of Colors	16.7M Colors (8-bit RGB)
Backlight	Light Emitting Diode (LED)
Weight	254g(typ)
Interface	LVDS ; 20pins
Power Supply Voltage	3.3V for LCD ; 12V for Backlight
Viewing Direction	Super Wide Version

4. ABSOLUTE MAXIMUM RATINGS

Item	Symbol	Min.	Max.	Unit	Remarks
Supply Voltage	V _{DD}	-0.3	4.6	V	-
Input Voltage of Logic	V _I	-0.3	4.6	V	Note 1
Operating Temperature	Top	-30	85	°C	Note 2
Storage Temperature	Tst	-40	90	°C	Note 2
Backlight Input Voltage	V _{LED}	-	15	V	-

Note 1: The rating is defined for the signal voltage of the interface such as CLK and pixel data pairs.

Note 2: The maximum rating is defined as above based on the panel surface temperature, which might be different from ambient temperature after assembling the panel into the application. Moreover, some temperature-related phenomenon as below needed to be noticed:

- Background color, contrast and response time would be different in temperatures other than 25°C.
- Operating under high temperature will shorten LED lifetime.

5. ELECTRICAL CHARACTERISTICS

5.1 LCD CHARACTERISTICS

$T_a = 25\text{ }^\circ\text{C}$, $V_{SS} = 0\text{V}$

Item	Symbol	Condition	Min.	Typ.	Max.	Unit	Remarks
Power Supply Voltage	V_{DD}	-	3.0	3.3	3.6	V	-
Differential Input Voltage for LVDS Receiver Threshold	V_I	V_{IH}	-	-	+100	mV	Note 1
		V_{IL}	-100	-	-		
Power Supply Current	I_{DD}	$V_{DD}-V_{SS} = 3.3\text{V}$	-	120	200	mA	Note 2,3
Frame Frequency	f_{Frame}	-	-	60	-	Hz	Note 4
CLK Frequency	f_{CLK}	-	-	67	-	MHz	

Note 1: VCM 1.2V is common mode voltage of LVDS transmitter and receiver. The input terminal of LVDS transmitter is terminated with 100Ω .

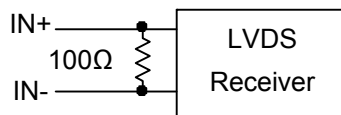

Note 2: An all white check pattern is used when measuring I_{DD} . f_{Frame} is set to 60Hz.

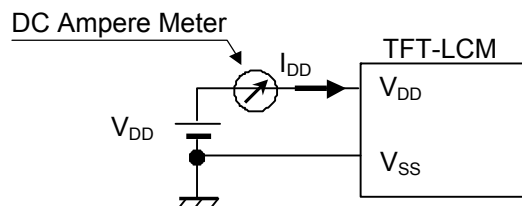

Note 3: (TBD) fuse is applied in the module for I_{DD} . For display activation and protection purpose, power supply is recommended larger than (TBD) to start the display and break fuse once any short circuit occurred.

Note 4: For LVDS transmitter input.

5.2 BACKLIGHT CHARACTERISTICS

$T_a = 25^\circ\text{C}$

Item	Symbol	Condition	Min.	Typ.	Max.	Unit	Remarks
LED Input Voltage	V_{LED}	Backlight Unit	10.8	12	13.2	V	Note 1
LED Forward Current (Dim Control)	I_{LED}	100% duty	-	590	-	mA	Note 2
		0% duty	-	6.0	-		
Backlight Enable	BLEN	Backlight Unit	1.5	-	5.5	V	
LED Lifetime	-	$I_{LED}=590\text{mA}$	-	70K	-	hrs	Note 3

Note 1: Fig. 5.1 shows the LED backlight circuit.

Note 2: Dimming function can be obtained by applying PWM signal from the display interface CN7. The recommended PWM signal is 1K ~ 10KHz with 3.3 V amplitude.

Note 3: The estimated lifetime is specified as the time to reduce 50% brightness by applying 590mA at 25°C .

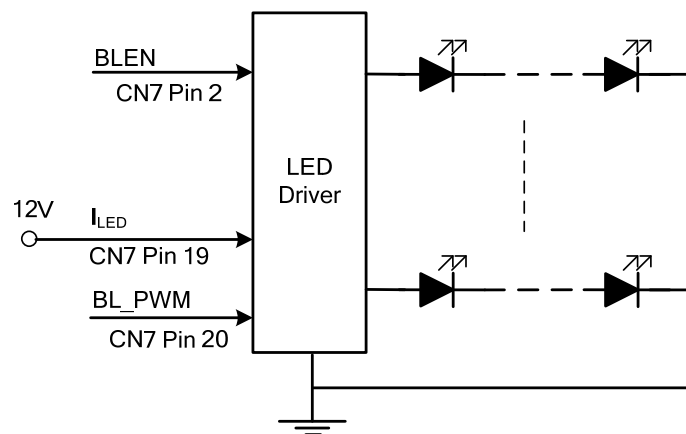

Fig 5.1

6. OPTICAL CHARACTERISTICS

The optical characteristics are measured based on the conditions as below:

- Supplying the signals and voltages defined in the section of electrical characteristics.
- The ambient temperature is 25 °C .
- In the dark room less than 100 lx, the equipment has been set for the measurements as shown in Fig 6.1.

$$T_a = 25 \text{ } ^\circ\text{C}, f_{Frame} = 60 \text{ Hz}, V_{DD} = 3.3\text{V}$$

Item	Symbol	Condition	Min.	Typ.	Max.	Unit	Remarks
Brightness of White	-	$I_{LED} = 590\text{mA}$ $\phi = 0^\circ, \theta = 0^\circ$	800	1000	-	cd/m ²	Note 1
Brightness Uniformity	-		70	-	-	%	Note 2
Contrast Ratio	CR		900	-	-	-	Note 3
Response Time	Tr + Tf	$\phi = 0^\circ, \theta = 0^\circ$	-	-	25	ms	Note 4
NTSC Ratio	-	$\phi = 0^\circ, \theta = 0^\circ$	-	70	-	%	-
Viewing Angle	θ_x	$\phi = 0^\circ, CR \geq 10$	-	85	-	Degree	Note 5
	$\theta_{x'}$	$\phi = 180^\circ, CR \geq 10$	-	85	-		
	θ_y	$\phi = 90^\circ, CR \geq 10$	-	85	-		
	$\theta_{y'}$	$\phi = 270^\circ, CR \geq 10$	-	85	-		
Color Chromaticity	Red	X	-	0.659	-	-	Note 6
		Y	-	0.326	-		
	Green	X	-	0.311	-		
		Y	-	0.630	-		
	Blue	X	-	0.143	-		
		Y	-	0.042	-		
	White	X	-	0.303	-		
		Y	-	0.319	-		

Note 1: The brightness is measured from the center point of the panel, P5 in Fig. 6.2, for the typical value.

Note 2: The brightness uniformity is calculated by the equation as below:

$$\text{Brightness uniformity} = \frac{\text{Min. Brightness}}{\text{Max. Brightness}} \times 100\%$$

which is based on the brightness values of the 9 points measured by BM-5 as shown in Fig. 6.2.

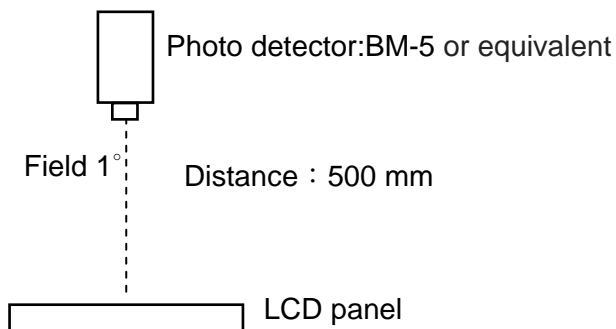

Fig. 6.1

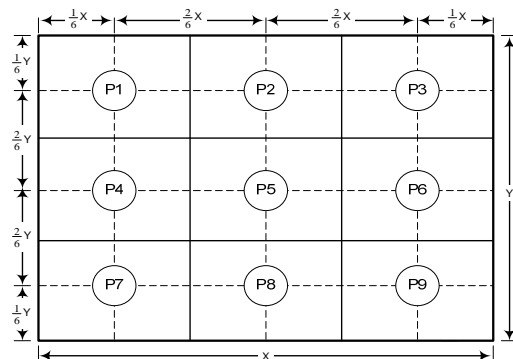

Fig. 6.2

Note 3: The Contrast ratio is measured from the center point of the panel, P5, and defined as the following equation:

$$CR = \frac{\text{Brightness of White}}{\text{Brightness of Black}}$$

Note 4: The definition of response time is shown in Fig. 6.3. The rising time is the period from 10% brightness to 90% brightness when the data is from black to white. Oppositely, Falling time is the period from 90% brightness falling to 10% brightness.

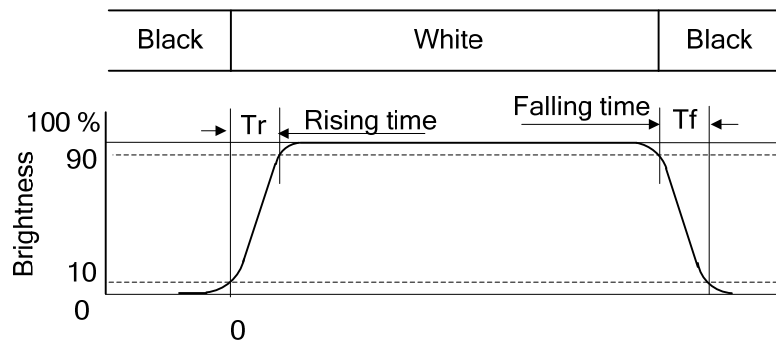

Fig. 6.3

Note 5: The definition of viewing angle is shown in Fig. 6.4. Angle ϕ is used to represent viewing directions, for instance, $\phi = 270^\circ$ means 6 o'clock, and $\phi = 0^\circ$ means 3 o'clock. Moreover, angle θ is used to represent viewing angles from axis Z toward plane XY.

The display is super wide viewing angle version, so that the best optical performance can be obtained from every viewing direction.

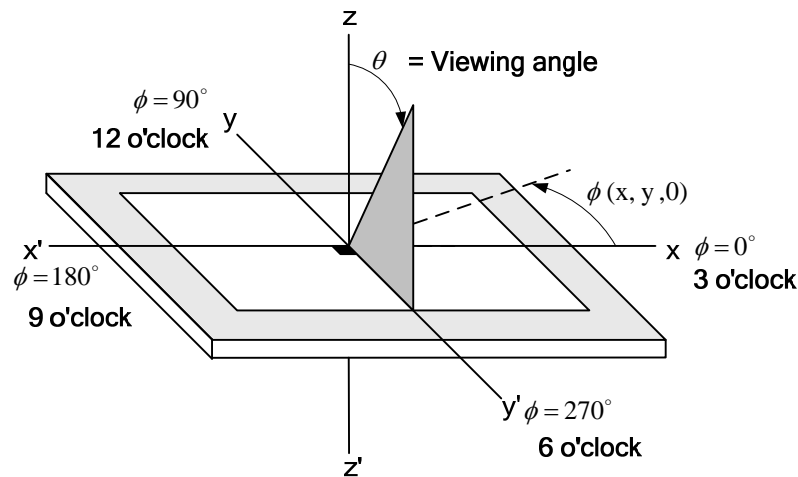
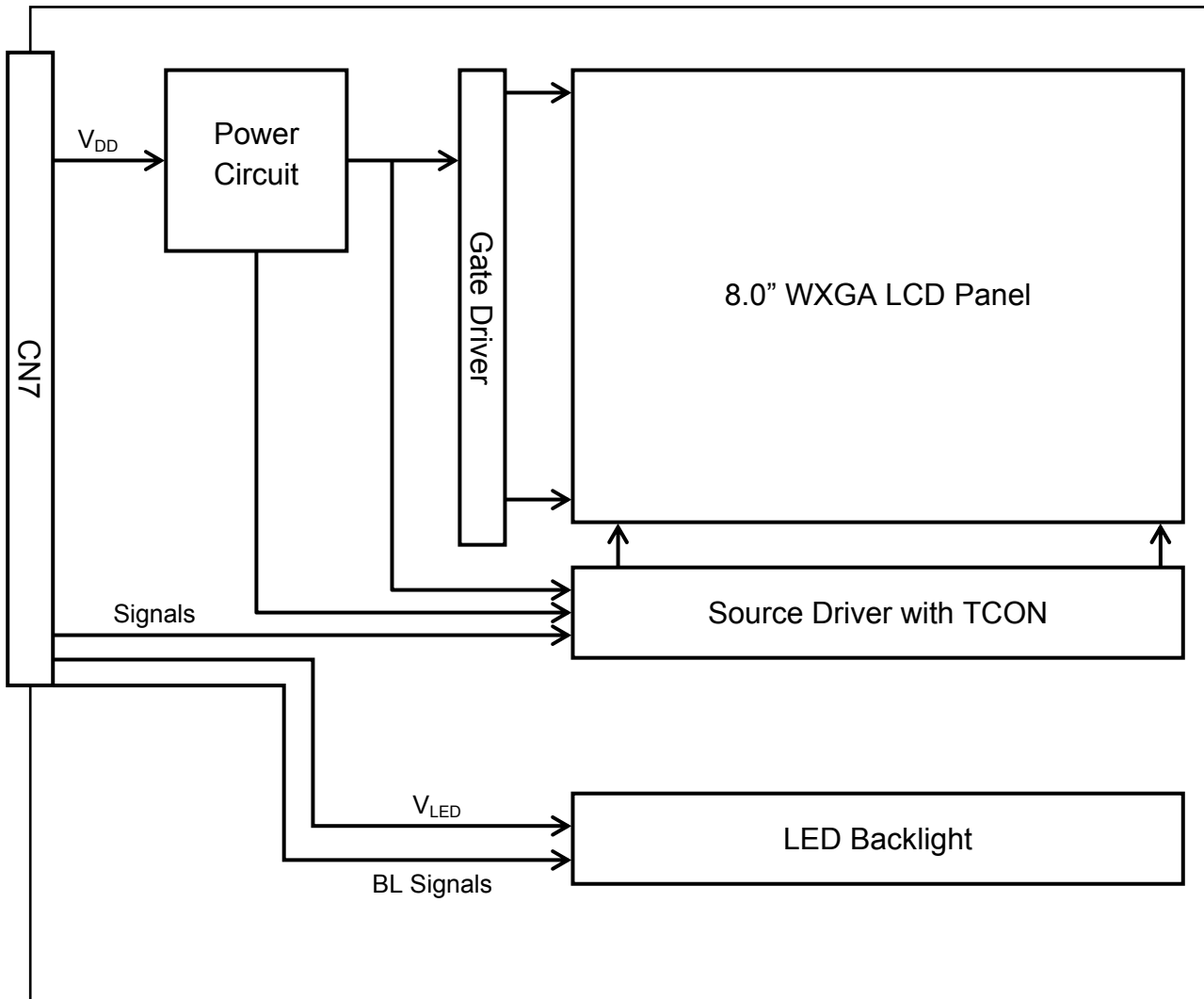

Fig. 6.4

Note 6: The color chromaticity is measured from the center point of the panel, P5, as shown in Fig. 6.2.

7. BLOCK DIAGRAM



Note :

- 1) Signals are UD/LR, CLK and pixel data pairs.
- 2) BL signals are BLEN and BL_PWM.

8. LCD INTERFACE

8.1 INTERFACE PIN CONNECTIONS

The display interface connector (CN3) is FI-SEB20P-HF13E made by JAE and pin assignment is as below:

Pin No.	Symbol	Signal	Pin No.	Symbol	Signal
1	V _{DD}	Power Supply for Logic	11	IN2-	B2~B5, DE
2	BLEN	Backlight Enable	12	IN2+	
3	V _{SS}	GND	13	V _{SS}	GND
4	UD/LR	Horizontal Display mode Control High :Normal, Low :Reverse	14	CLK IN-	Pixel Clock
5	IN0-	R0~R5, G0	15	CLK IN+	
6	IN0+		16	V _{SS}	GND
7	V _{SS}	GND	17	IN3-	R6, R7, G6, G7, B6, B7
8	IN1-	G1~G5, B0~B1	18	IN3+	
9	IN1+		19	V _{LED}	Backlight power input
10	V _{SS}	GND	20	BL_PWM	Backlight Dimming

Note 1: IN n- and IN n+ (n=0, 1, 2, 3), CLK IN- and CLK IN+ should be wired by twist-pairs.

8.2 LVDS INTERFACE

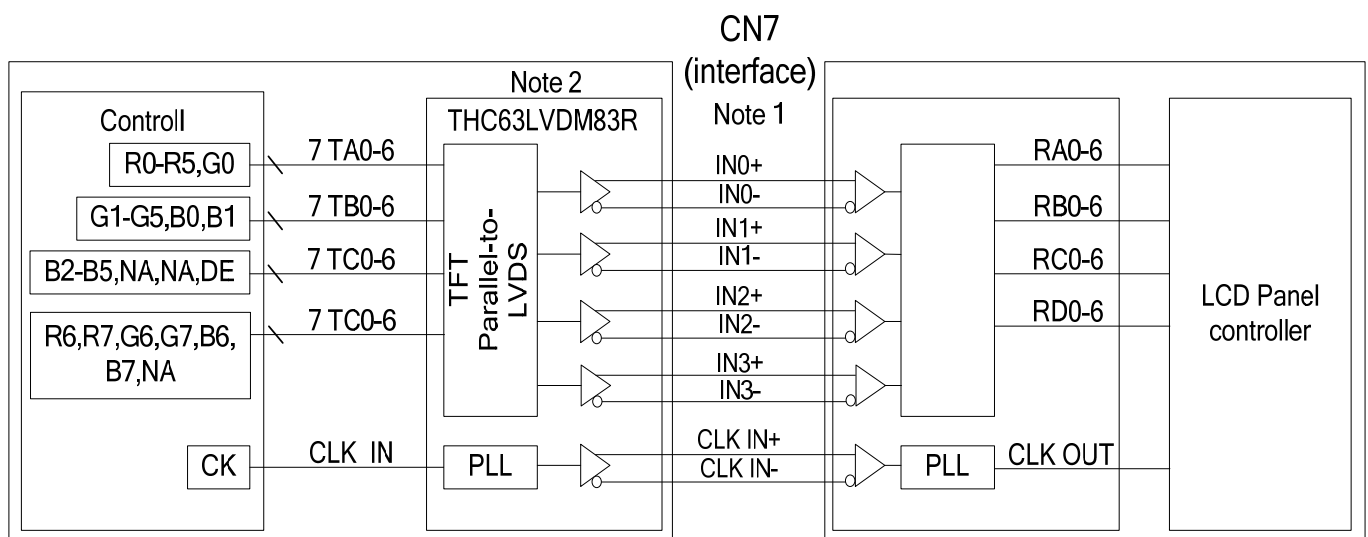

Note 1: LVDS cable impedance should be 100 ohms per signal line when each 2-lines (+, -) is used in differential mode.

Note 2: The recommended transmitter, TH63LVDM83R, is made by Thine or equivalent, which is not contained in the module.

8.3 TIMING CHART

Horizontal timing

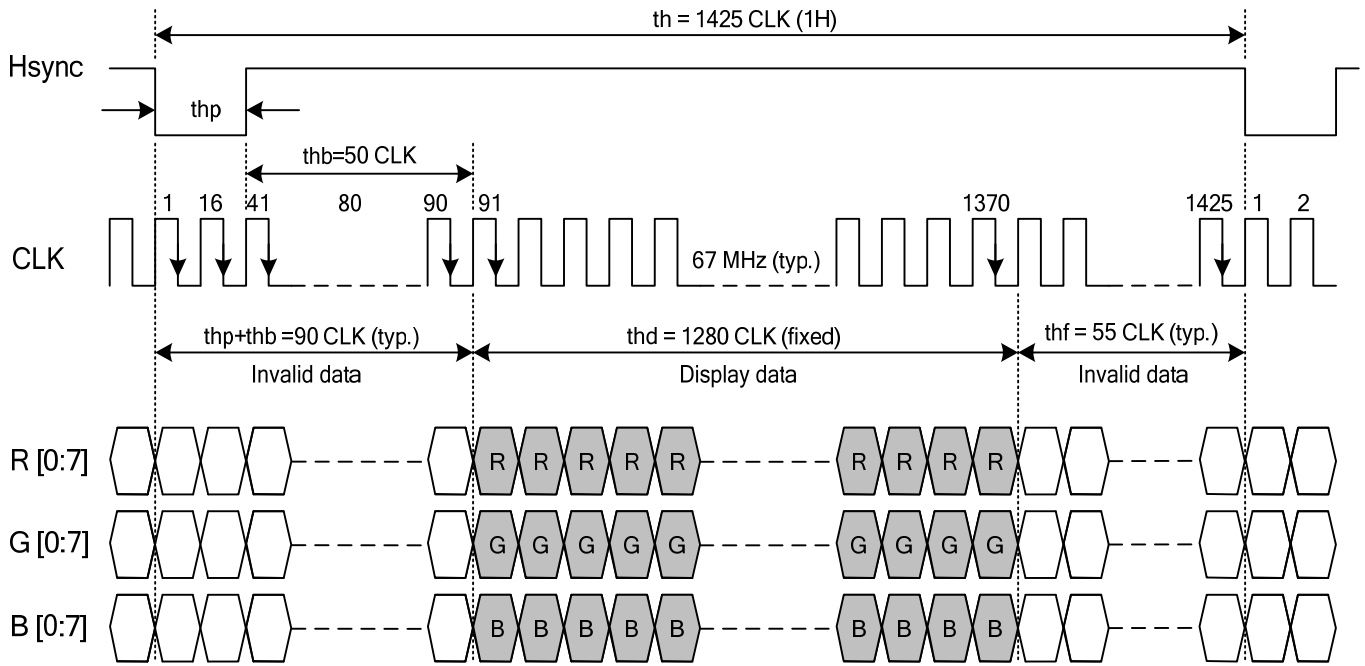

Fig. 8.1 Horizontal Timing of Synchronous Mode

Note 1: CLK's falling edge is the time to latch data and count ($thp + thb$), therefore, data sending and Hsync's falling edge should start when CLK's rise edge.

Vertical timing

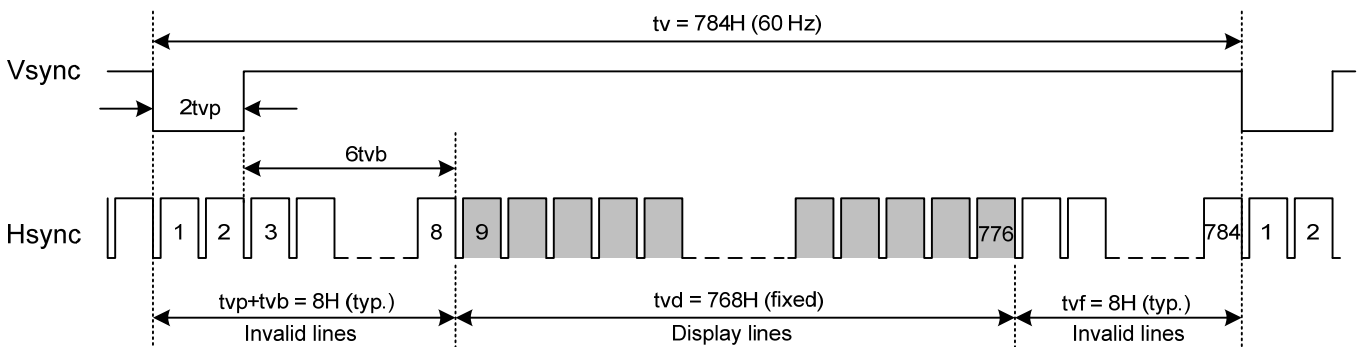

Fig. 8.2 Vertical Timing of Synchronous Mode

Note 2: Vsync's falling edge needs to start with Hsync's falling edge simultaneously to count ($tvp + tvb$)

8.4 TIMING TABLE

The column of timing sets including minimum, typical, and maximum as below are based on the best optical performance, frame frequency (f_{Frame}) = 60 Hz to define.

A. DE MODE

	Item	Symbol	Min.	Typ.	Max.	Unit
Horizontal	CLK Frequency	fclk	-	67	-	M Hz
	Display Data	thd	1280			CLK
	Cycle Time	th	-	1425	-	
Vertical	Display Data	tvd	768			H
	Cycle Time	tv	-	784	-	

8.5 DISPLAY MODE CONTROL

Scan direction is available to be switched as below by setting CN7's UD/ LR pin.

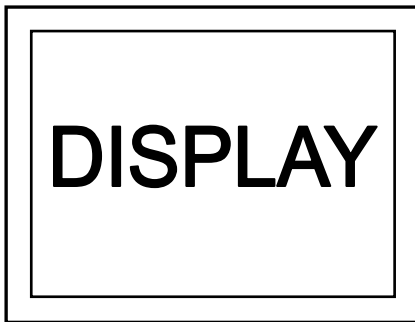

UD/LR : High



UD/LR : Low

8.6 LVDS RECEIVER TIMING

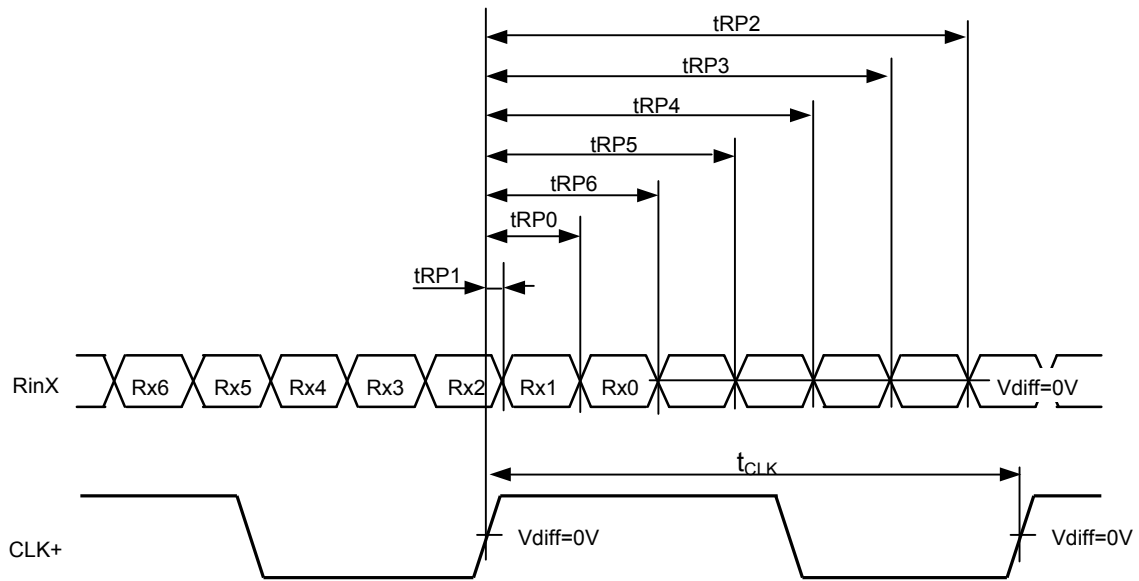

$$RinX = (RinX+) - (RinX-) \quad (X=0, 1, 2)$$

	Item	Symbol	Min.	Typ.	Max.	Unit
CLK	Cycle frequency	$1/t_{CLK}$	-	67	-	MHz
RinX (X=0,1,2)	0 data position	t_{RP0}	-	$1/7 * t_{CLK}$	-	ns
	1st data position	t_{RP1}	-	0	-	
	2nd data position	t_{RP2}	-	$6/7 * t_{CLK}$	-	
	3rd data position	t_{RP3}	-	$5/7 * t_{CLK}$	-	
	4th data position	t_{RP4}	-	$4/7 * t_{CLK}$	-	
	5th data position	t_{RP5}	-	$3/7 * t_{CLK}$	-	
	6th data position	t_{RP6}	-	$2/7 * t_{CLK}$	-	

8.7 POWER SEQUENCE

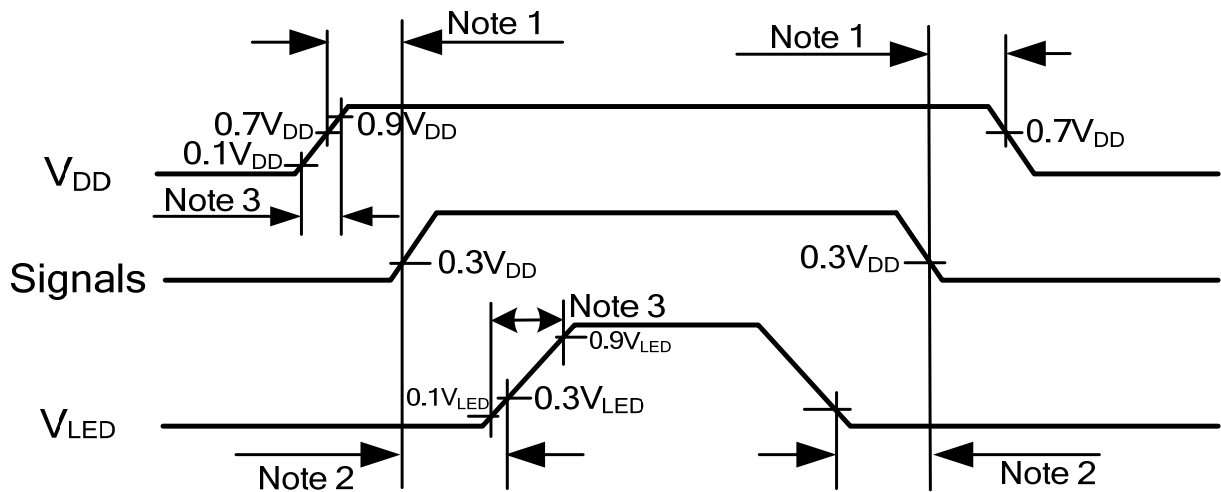

Note 1: In order to avoid any damages, V_{DD} has to be applied before all other signals. The opposite is true for power off where V_{DD} has to be remained on until all other signals have been switch off. The recommended time period is 1 second.

Note 2: In order to avoid showing uncompleted patterns in transient state. It is recommended that switching the backlight on is delayed for 1 second after the signals have been applied. The opposite is true for power off where the backlight has to be switched off 1 second before the signals are removed.

Note 3: In order to avoid high Inrush current, V_{DD} rising time need to set more than 0.5ms.

8.8 DATA INPUT for DISPLAY COLOR

Input color		Red Data								Green Data								Blue Data													
		R7	R6	R5	R4	R3	R2	R1	R0	G7	G6	G5	G4	G3	G2	G1	G0	B7	B6	B5	B4	B3	B2	B1	B0						
		MSB								LSB								MSB								LSB					
Basic Color	Black	0	0	0	0	0	0	0	0	0	0	0	0	0	0	0	0	0	0	0	0	0	0	0							
	Red(255)	1	1	1	1	1	1	1	1	0	0	0	0	0	0	0	0	0	0	0	0	0	0	0							
	Green(255)	0	0	0	0	0	0	0	0	1	1	1	1	1	1	1	1	0	0	0	0	0	0	0							
	Blue(255)	0	0	0	0	0	0	0	0	0	0	0	0	0	0	0	0	1	1	1	1	1	1	1							
	Cyan	0	0	0	0	0	0	0	0	1	1	1	1	1	1	1	1	1	1	1	1	1	1	1							
	Magenta	1	1	1	1	1	1	1	1	0	0	0	0	0	0	0	0	1	1	1	1	1	1	1							
	Yellow	1	1	1	1	1	1	1	1	1	1	1	1	1	1	1	1	0	0	0	0	0	0	0							
	White	1	1	1	1	1	1	1	1	1	1	1	1	1	1	1	1	1	1	1	1	1	1	1							
Red	Black	0	0	0	0	0	0	0	0	0	0	0	0	0	0	0	0	0	0	0	0	0	0								
	Red(1)	0	0	0	0	0	0	0	1	0	0	0	0	0	0	0	0	0	0	0	0	0	0								
	Red(2)	0	0	0	0	0	0	1	0	0	0	0	0	0	0	0	0	0	0	0	0	0	0								
	:	:	:	:	:	:	:	:	:	:	:	:	:	:	:	:	:	:	:	:	:	:	:								
	Red(253)	1	1	1	1	1	1	0	1	0	0	0	0	0	0	0	0	0	0	0	0	0	0								
	Red(254)	1	1	1	1	1	1	1	0	0	0	0	0	0	0	0	0	0	0	0	0	0	0								
	Red(255)	1	1	1	1	1	1	1	1	0	0	0	0	0	0	0	0	0	0	0	0	0	0								
Green	Black	0	0	0	0	0	0	0	0	0	0	0	0	0	0	0	0	0	0	0	0	0	0								
	Green(1)	0	0	0	0	0	0	0	0	0	0	0	0	0	0	1	0	0	0	0	0	0	0								
	Green(2)	0	0	0	0	0	0	0	0	0	0	0	0	0	1	0	0	0	0	0	0	0	0								
	:	:	:	:	:	:	:	:	:	:	:	:	:	:	:	:	:	:	:	:	:	:	:								
	Green(253)	0	0	0	0	0	0	0	0	1	1	1	1	1	1	0	1	0	0	0	0	0	0								
	Green(254)	0	0	0	0	0	0	0	0	1	1	1	1	1	1	0	0	0	0	0	0	0	0								
	Green(255)	0	0	0	0	0	0	0	0	1	1	1	1	1	1	1	0	0	0	0	0	0	0								
Blue	Black	0	0	0	0	0	0	0	0	0	0	0	0	0	0	0	0	0	0	0	0	0	0								
	Blue(1)	0	0	0	0	0	0	0	0	0	0	0	0	0	0	0	0	0	0	0	0	0	1								
	Blue(2)	0	0	0	0	0	0	0	0	0	0	0	0	0	0	0	0	0	0	0	0	1	0								
	:	:	:	:	:	:	:	:	:	:	:	:	:	:	:	:	:	:	:	:	:	:	:								
	Blue(253)	0	0	0	0	0	0	0	0	0	0	0	0	0	0	0	1	1	1	1	1	1	0								
	Blue(254)	0	0	0	0	0	0	0	0	0	0	0	0	0	0	0	1	1	1	1	1	1	0								
	Blue(255)	0	0	0	0	0	0	0	0	0	0	0	0	0	0	0	1	1	1	1	1	1	1								

Note 1: Definition of gray scale : Color(n) Number in parenthesis indicates gray scale level. Larger number corresponds to brighter level.

Note 2: Data Signal : 1 : High, 0 : Low

9. OUTLINE DIMENSIONS

9.1 FRONT VIEW

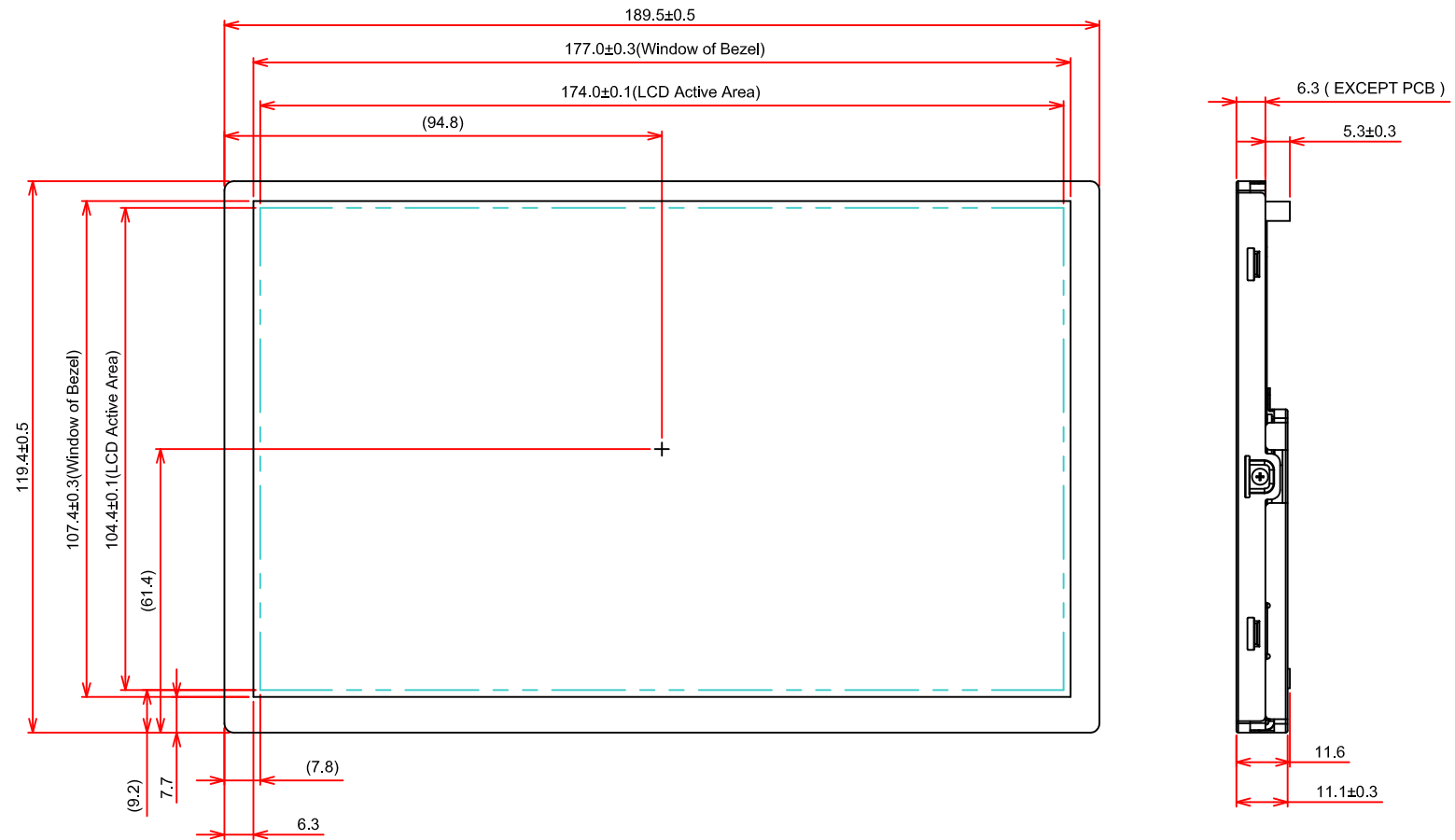

General Tolerance: ± 0.5 mm
Scale : NTS
Unit : mm

9.2 REAR VIEW

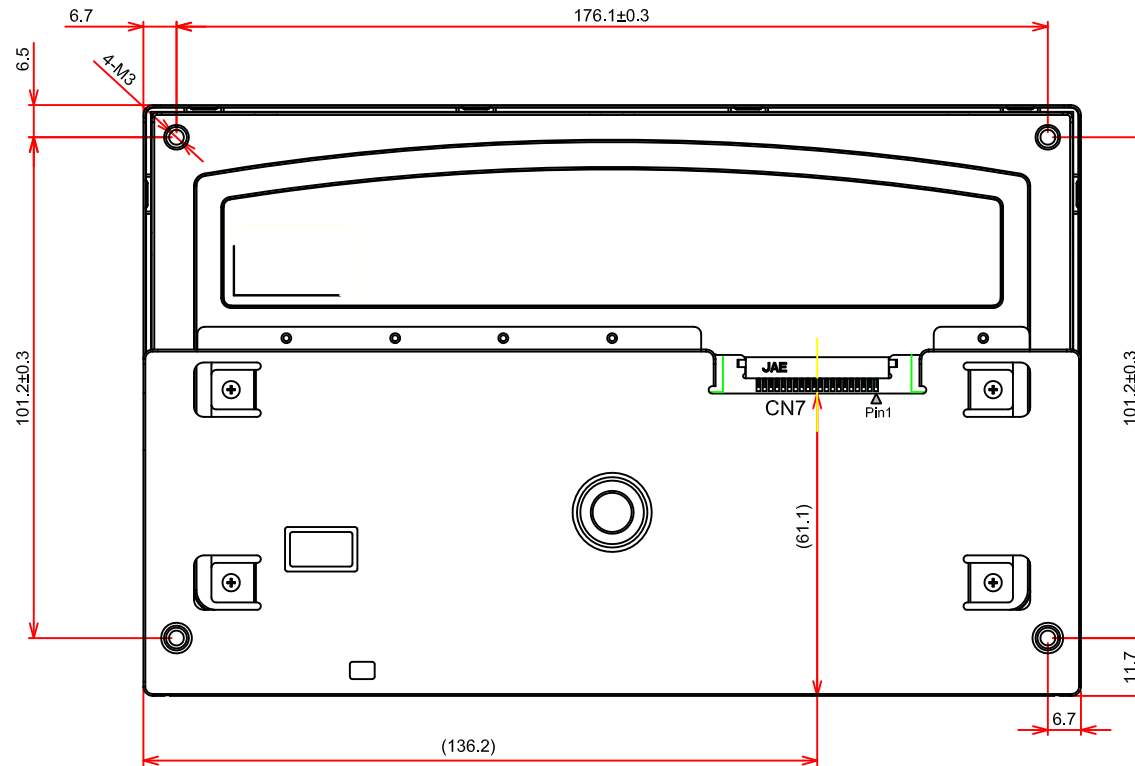

General Tolerance:±0.5mm
Scale : NTS
Unit : mm

9. DESIGNATION of LOT MARK

1) The lot mark is showing in Fig.10.1. First 4 digits are used to represent production lot, T represented made in Taiwan, and the last 6 digits are the serial number.

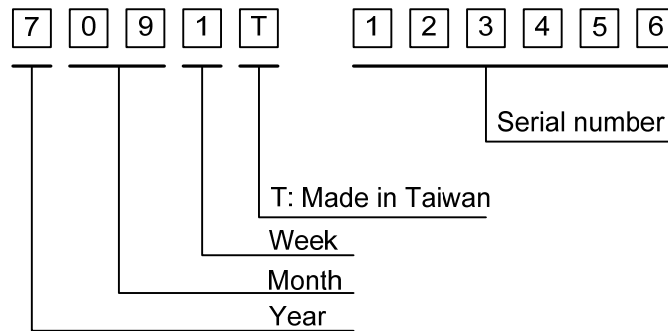

Fig. 10.1

2) The tables as below are showing what the first 4 digits of lot mark are shorted for.

Year	Lot Mark
2019	9
2020	0
2021	1
2022	2
2023	3

Month	Lot Mark	Month	Lot Mark
Jan.	01	Jul.	07
Feb.	02	Aug.	08
Mar.	03	Sep.	09
Apr.	04	Oct.	10
May	05	Nov.	11
Jun.	06	Dec.	12

Week	Lot Mark
1~7 days	1
8~14 days	2
15~21 days	3
22~28 days	4
29~31 days	5

3) The location of the lot mark is on the back of the display shown in Fig. 10.2

Label example :

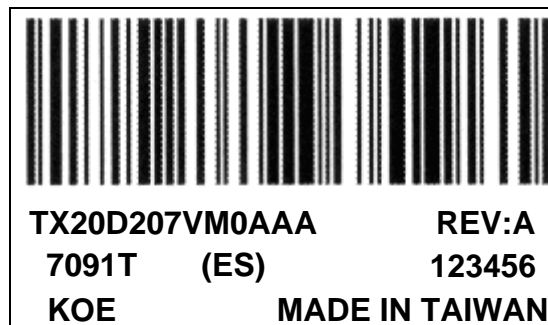

Fig. 10.2